

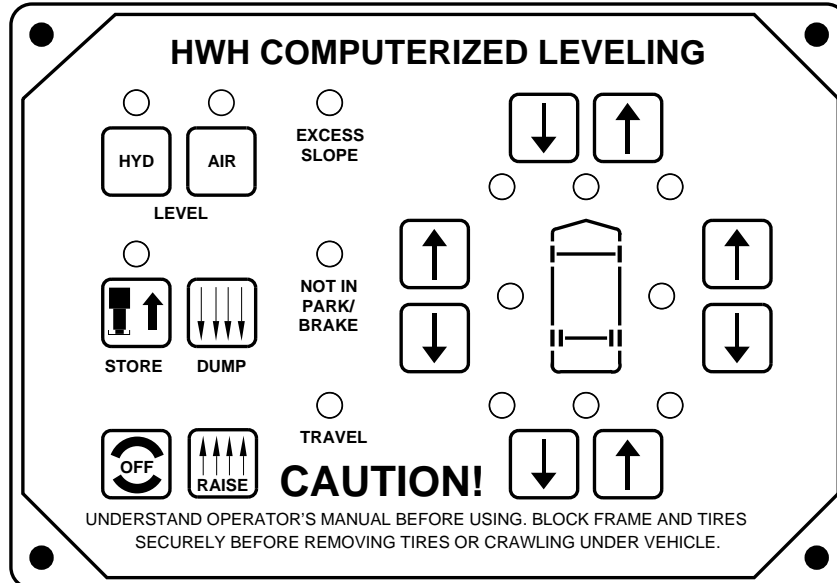

OPERATOR'S MANUAL

HWH COMPUTER-CONTROLLED LEVELING SYSTEM 600 SERIES

FEATURING:
TOUCH PANEL CONTROL
HYDRAULIC LEVELING
AIR LEVELING
STRAIGHT-ACTING JACKS



HWH CORPORATION
(ON I-80, EXIT 267 SOUTH)
2096 MOSCOW ROAD
MOSCOW, IOWA 52760
(800) 321-3494 / (563) 724-3396
INTERNET: <http://www.hwhcorp.com>

OPERATOR'S MANUAL

CAUTION !

READ THE ENTIRE OPERATOR'S MANUAL BEFORE OPERATING.

BLOCK FRAME AND TIRES SECURELY BEFORE CRAWLING UNDER VEHICLE. DO NOT USE LEVELING JACKS OR AIR SUSPENSION TO SUPPORT VEHICLE WHILE UNDER VEHICLE OR CHANGING TIRES. VEHICLE MAY DROP AND/OR MOVE FORWARD OR BACKWARD WITHOUT WARNING CAUSING INJURY OR DEATH.

KEEP ALL PEOPLE CLEAR OF VEHICLE WHILE LEVELING SYSTEM AND ROOM EXTENSION ARE BEING OPERATED.

NEVER PLACE HANDS OR OTHER PARTS OF THE BODY NEAR HYDRAULIC LEAKS. OIL MAY PENETRATE SKIN CAUSING INJURY OR DEATH.

DO NOT OPERATE THE LEVELING SYSTEM OR USE THE DUMP OR RAISE BUTTONS IF THE VEHICLE IS MOVING IN EXCESS OF 5 MPH.

WEAR SAFETY GLASSES WHEN INSPECTING OR SERVICING THE SYSTEM TO PROTECT EYES FROM DIRT, METAL CHIPS, OIL LEAKS, ETC. FOLLOW ALL OTHER APPLICABLE SHOP SAFETY PRACTICES.

IMPORTANT: IF COACH IS EQUIPPED WITH A ROOM EXTENSION, READ ROOM EXTENSION SECTION BEFORE OPERATING LEVELING SYSTEM.

HOW TO OBTAIN WARRANTY SERVICE

THIS IS NOT TO BE INTERPRETED AS A STATEMENT OF WARRANTY

HWH CORPORATION strives to maintain the highest level of customer satisfaction. Therefore, if you discover a defect or problem, please do the following:

FIRST: Notify the dealership where you purchased the vehicle or had the leveling system installed. Dealership management people are in the best position to resolve the problem quickly. If the dealer has difficulty solving the problem, he should immediately contact the Customer Service Department, at HWH CORPORATION.

SECOND: If your dealer cannot or will not solve the problem, notify the Customer Service Department:
HWH CORPORATION 2096 Moscow Rd. Moscow IA. 52760
(563) 724-3396 OR (800) 321-3494. Give your name and address, coach manufacturer and model year, date the coach was purchased, or the date of system installation,

description of the problem, and where you can be reached during business hours (8:00 a.m. till 5:00 p.m. c.s.t.). HWH CORPORATION personnel will contact you to determine whether or not your claim is valid. If it is, HWH CORPORATION will authorize repair or replacement of the defective part, either by appointment at the factory or by the authorization of an independent service facility, to be determined by HWH CORPORATION. All warranty repairs must be performed by an independent service facility authorized by HWH CORPORATION, or at the HWH CORPORATION factory, unless prior written approval has been obtained from proper HWH CORPORATION personnel.

CONTROL IDENTIFICATION

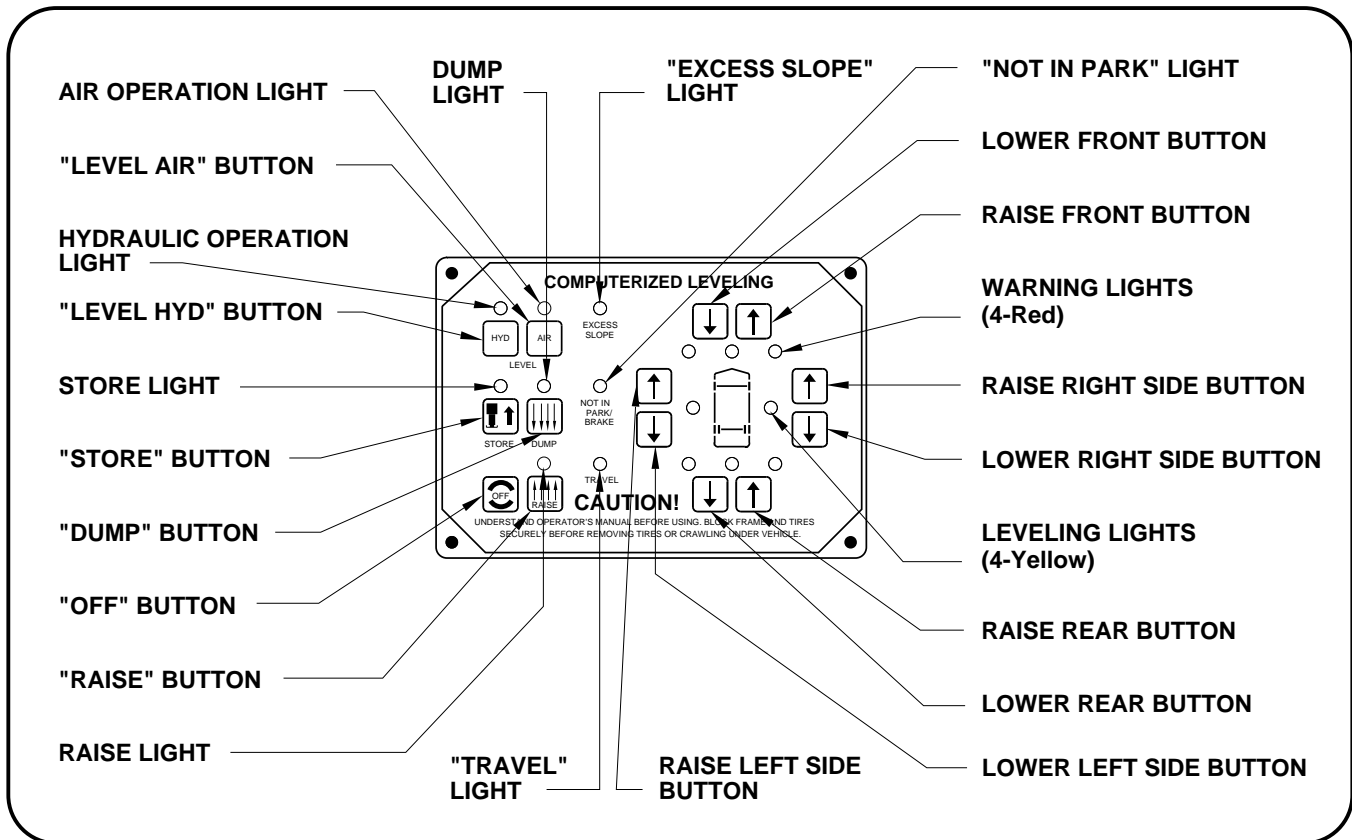

CONTROL FUNCTIONS

CONTROL BUTTONS

"OFF" BUTTON: Push the "OFF" button to stop the hydraulic or air operation.

"LEVEL HYD" BUTTON: This is the on and automatic operation button for hydraulic leveling.

"STORE" BUTTON: This button is used to automatically retract the jacks into the STORE/TRAVEL position.

"LEVEL AIR" BUTTON: This is the on and automatic operation button for air leveling.

"DUMP" BUTTON: This button will lower the whole vehicle by exhausting air from the suspension system.

"RAISE" BUTTON: This button will raise the whole vehicle by adding air to the suspension system.

IMPORTANT: READ "DUMP" AND "RAISE" FUNCTIONS SECTION CAREFULLY.

RAISE BUTTONS (UP ARROW): These momentary buttons are used for manually operating the air or hydraulic leveling systems. Sides or ends of the vehicle will raise while these buttons are pushed.

LOWER BUTTONS (DOWN ARROWS): These are momentary buttons used for manually operating the air or hydraulic leveling systems. Sides or ends of the vehicle will lower while these buttons are pushed.

INDICATOR LIGHTS

AIR OPERATION LIGHT: This light indicates the system is in the AIR LEVELING mode.

HYDRAULIC OPERATION LIGHT: This light indicates the system is in the HYDRAULIC LEVELING mode.

STORE LIGHT: This light will flash indicating the hydraulic system is in the STORE mode.

RAISE LIGHT: This light will flash when the "RAISE" button is pushed.

DUMP LIGHT: This light will flash when the "DUMP" button is pushed.

CONTROL IDENTIFICATION

CONTROL FUNCTIONS (CONT'D)

INDICATORS (CONT'D)

"EXCESS SLOPE" INDICATOR LIGHT: This light will be on if the leveling system can NOT level the vehicle.

"TRAVEL" INDICATOR LIGHT: This light will be on if the ignition is "ON" and there are no red WARNING lights.

CAUTION: IT IS THE OPERATOR'S RESPONSIBILITY TO CHECK THAT ALL JACKS ARE IN THE STORE/TRAVEL POSITION AND THE AIR SUSPENSION IS AT THE PROPER TRAVEL HEIGHT.

"NOT IN PARK" INDICATOR LIGHT: This light will be on if the "AIR" or "HYD" button is being pushed and the park brake is not set, provided the ignition is in the "ON" position.

WARNING INDICATOR LIGHTS: When a jack is extended 2 inches or more, the respective red WARNING light will be on, if the HYDRAULIC OPERATION indicator light is on. If the AIR OPERATION indicator light is on and the ignition is in the "ON" position all four red WARNING lights will be on. The vehicle should not be moved if a red WARNING light is on.

LEVEL INDICATOR LIGHTS : There are four yellow LEVEL indicator lights. A lit LEVEL indicator light indicates a side or end of the vehicle is low. These lights can be on only if the AIR or HYDRAULIC indicator lights are on. Only one or two LEVEL indicator lights can be on at once. When all LEVEL indicator lights are out the vehicle is level.

MASTER WARNING LIGHT : This light will be on if the ignition is in the "ON" position and a jack is extended 2 inches or more, or if a suspension air bag has low air pressure. The vehicle should NOT be moved if this light is on.

WARNING BUZZER : The buzzer will sound if the ignition is in the "ON" position and a jack is extended 2 inches or more, or if a suspension air bag has low air pressure. The vehicle should not be moved if the buzzer is on.

OPERATING PROCEDURES

GENERAL INSTRUCTIONS

If parking on soft ground or asphalt paving, pads should be placed under the jacks for hydraulic leveling.

Read room operating procedures before operating any rooms.

Press the "OFF" button at any time to stop the operation of the system

NOTE: If the ignition switch is "ON" the vehicle's air suspension may return to travel height.

If the ignition is in the "ON" position and the park brake is not set, the "NOT IN PARK/BRAKE" light will come on, and the system will not turn on when either the "AIR" or "HYD" button is pressed. If the ignition is in the "ON" position, either air or hydraulic leveling will be stopped anytime the park brake is

released. The system will shut off and the vehicle suspension system will return to travel height.

Air and hydraulic leveling can not be used simultaneously.

The "DUMP" and "RAISE" buttons will function with the system and park brake off if the ignition is in the "ON" position. See AIR DUMP AND RAISE FUNCTIONS.

The MASTER WARNING light and buzzer will be on if a jack is extended two inches or more or if an air bag has low air pressure if the ignition is in the "ON" position.

CAUTION: DO NOT MOVE THE VEHICLE IF A WARNING LIGHT OR BUZZER IS ON, OR IF THE ROOM EXTENSION IS EXTENDED.

PREPARATION FOR TRAVEL

Start the vehicle's engine and allow air pressure to build to recommended level for traveling.

Check that the room extension is fully retracted.

Visually check that the jacks are in the STORE/TRAVEL position. Also check that the vehicle's suspension is at the proper height for travel.

The "TRAVEL" light on the leveling panel must be on.

Before traveling, the MASTER WARNING light and buzzer must be off.

CAUTION: DO NOT MOVE THE VEHICLE WHILE THE LEVELING JACKS ARE STILL IN CONTACT WITH THE GROUND OR IN THE EXTEND POSITION. THIS VEHICLE IS EQUIPPED WITH STRAIGHT-ACTING JACKS. MOVING THE VEHICLE WITH THE LEVELING JACKS EXTENDED CAN CAUSE SEVERE DAMAGE TO THE JACKS AND OR THE VEHICLE AND CREATE A DRIVING HAZARD. DO NOT RELY SOLELY UPON WARNING LIGHTS. IT IS THE OPERATOR'S RESPONSIBILITY TO CHECK THAT ALL JACKS ARE FULLY RETRACTED INTO THE STORE POSITION.

CAUTION: IT IS THE OPERATOR'S RESPONSIBILITY TO CHECK THAT THE VEHICLE IS AT THE PROPER RIDE HEIGHT BEFORE TRAVELING.

HYDRAULIC OPERATION AUTOMATIC HYDRAULIC LEVELING

NOTE: Hydraulic leveling can be used with the ignition in the "ON" or "ACC" position. When the leveling system is off and the ignition is in the "ON" position, the vehicles suspension can return to travel height.

1. Place the transmission in the recommended position for parking the vehicle and set the park brake.

2. At this time, the operator may want to check the jacks and place pads under the jacks if the ground will not support the vehicle on the jacks.

3. Turn the ignition to the "ACC" position.

4. Press the "HYD" button to enter the hydraulic operation mode. The HYDRAULIC OPERATION indicator light will glow steady.

5. Press the "HYD" button a second time. The HYDRAULIC OPERATION indicator light will start to flash. The system will begin to dump air from the vehicle's suspension. After approximately 25 seconds the system will automatically extend jacks to level the vehicle and then extend any remaining jacks

until they touch the ground. After the system has finished leveling and stabilizing, and has completed the air dump cycle, it will automatically shut off.

NOTE: Air will continue to dump during the leveling process. The panel will stay on 45 seconds regardless of the time taken to level the vehicle.

EXCESS SLOPE SITUATION: In the event that the jacks are unable to level the vehicle, the "EXCESS SLOPE" indicator light will come on. The pump will shut off. One or two yellow LEVELING indicator lights will remain on. The HYDRAULIC OPERATION indicator light will continue to flash for 2 minutes, then the system will shut off. The system will not stabilize the vehicle if the "EXCESS SLOPE" light comes on. Store the jacks according to the JACK RETRACTION Section. Move the vehicle to a more level position or level the vehicle as close as possible according to the MANUAL HYDRAULIC OPERATION Section.

6. Turn the ignition switch to the "OFF" position.

OPERATING PROCEDURES

HYDRAULIC OPERATION (Cont'd)

JACK RETRACTION

CAUTION: THE OPERATOR MUST BE SURE THERE ARE NO OBJECTS UNDER THE VEHICLE AND THAT ALL PEOPLE ARE CLEAR OF THE VEHICLE.

1. Start the vehicle engine to build air pressure. Immediately start the retract procedure.
2. Press the "HYD" button one time. The HYDRAULIC OPERATION indicator light will glow steady.
3. Press the "STORE" button. The STORE indicator light will flash. For ten seconds air will be pumped into the air bags, then the jacks will start retracting. The vehicle can be moved as soon as the WARNING indicators are off, the green "TRAVEL" light is on and the vehicle has returned to the proper travel height, providing the jacks are in the STORE/TRAVEL position.

IMPORTANT: DO NOT interrupt power to the leveling system while the STORE indicator light is blinking. DO NOT push the "OFF" button. The system must be allowed to completely finish the STORE mode. The park brake may be removed and the vehicle may be moved when the jacks are in the STORE/TRAVEL position. This will not interrupt the store procedure.

CAUTION: DO NOT MOVE THE VEHICLE WHILE THE LEVELING JACKS ARE STILL IN CONTACT WITH THE GROUND OR IN THE EXTEND POSITION. THIS VEHICLE IS EQUIPPED WITH STRAIGHT-ACTING JACKS. MOVING THE VEHICLE WITH THE LEVELING JACKS EXTENDED CAN CAUSE SEVERE DAMAGE TO THE JACKS AND OR THE VEHICLE AND CREATE A DRIVING HAZARD. DO NOT RELY SOLELY UPON WARNING LIGHTS. IT IS THE OPERATOR'S RESPONSIBILITY TO CHECK THAT ALL JACKS ARE FULLY RETRACTED INTO THE STORE POSITION.

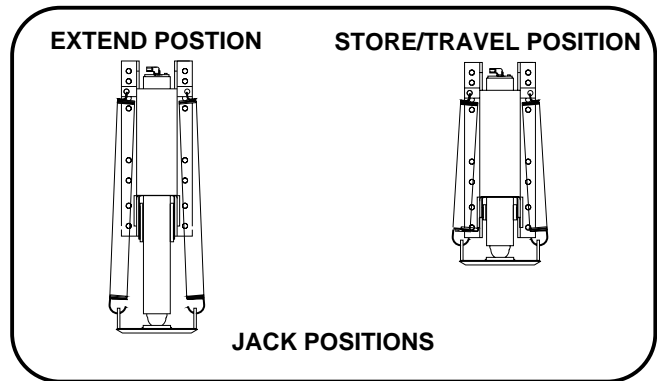

4. The system will automatically shut down six minutes after the four individual red WARNING lights are out. If any one of the red WARNING light does not go out the system will continue to store for 30 minutes, then shut down regardless of the WARNING lights condition.
5. Turn the ignition to "OFF" or proceed to travel.

NOTE : If jacks can not be retracted by the above procedure see MANUAL JACK RETRACTION Section.

MANUAL HYDRAULIC OPERATION

1. Place the transmission in the recommended position for parking the vehicle and set the park brake. Turn the ignition to the "ACC" position.

NOTE : If the ignition is in the "ON" position and the leveling system is off, the vehicle may return to travel height.

2. Press the "HYD" button. The indicator light will glow steady. Place pads under the jack feet if the ground will not support the vehicle on the jacks.
3. Press and hold the "DUMP" button until all the air is exhausted from the suspension air bags.
4. The vehicle may be leveled using the manual RAISE buttons (up arrows) on the right half of the panel. If a yellow LEVEL sensing light is on, that side or end of the vehicle is low. Level

the vehicle from side to side before doing front to rear leveling. Jacks will extend (or retract) in pairs to raise (or lower) a side or end of the vehicle. When a jack is extended approximately two inches or more the respective red WARNING light will come on.

5. After leveling is complete, any jack not used for leveling can be extended to the ground. Use the front or rear up arrows as needed. Do not use the side arrows. This provides additional stability against wind and activity in the vehicle.
6. Push the "OFF" button and turn the ignition switch to the "OFF" position.

OPERATING PROCEDURES

HYDRAULIC OPERATION (Cont'd)

MANUAL JACK RETRACTION

NOTE: Use the valve release "T" handles for retracting only if the "STORE" button on the control panel will not retract the jacks for travel.

CAUTION: KEEP AWAY FROM THE WHEELS, DO NOT CRAWL UNDER THE VEHICLE, KEEP A SAFE DISTANCE IN FRONT AND REAR OF VEHICLE. THE VEHICLE MAY DROP AND/OR MOVE FORWARD OR BACKWARD WITHOUT WARNING AS THE VALVE RELEASE IS OPERATED.

1. Locate the 4 valve release "T" handles on the solenoid valves. The solenoid valves are located on the valve manifold assembly.
2. Allow clearance for vehicle to lower.
3. Retract the front jacks by opening the two center valves. Slowly turn the "T" handles counter clockwise. The handles

may turn easily at first but as an internal spring is compressed, turning may become more difficult. The valves need only to be opened enough to retract the jack.

4. Retract the rear jacks by opening the two outer valves as described in Step 3.
5. Check that all four jacks are now retracted.
6. Close the valves by turning the release handles clockwise.

Once the internal spring tension has been released, the handles will turn free for several turns. Once the "T" handles are snug, DO NOT tighten the handles past this point as internal damage may occur to the solenoid.

7. The system should now be repaired before using again.

AIR OPERATION

AUTOMATIC AIR OPERATION

1. Place the transmission in the proper position for parking and set the park brake. Air leveling will operate with the ignition key in any position. Running the vehicle engine during air leveling is recommended. This will provide a better air supply for leveling. The vehicle will level with the engine shut off, however more time will be required for leveling.

NOTE: If the ignition key is in the "ON" position, the panel will not turn on if the park brake is not set. The "NOT IN PARK/BRAKE" light will come on while the "AIR" button is being pushed.

2. Press the "AIR" button once to enter the air mode. The AIR OPERATION indicator light will glow steady. If the ignition is in the "ON" position, the four red WARNING lights on the panel will come on. This indicates that the height control valves have been locked out. The vehicle should not be moved when these lights are on.

3. Press the "AIR" button a second time. The AIR OPERATION indicator light will start flashing and air leveling will begin. The system will attempt to level the vehicle by exhausting air from the air bags. If a level position is not achieved by lowering the vehicle, the low side and/or end of the vehicle will be raised by adding air to the air bags. When all four LEVEL SENSING lights

are out the leveling is complete. The AIR OPERATION indicator light will stop flashing, but will remain on. If there are no LEVEL SENSING lights on when air leveling is started, the AIR OPERATION indicator light will flash for 3 seconds and then will be steady.

When the AIR OPERATION indicator light is on steady, the processor will be in a sleep mode for 30 minutes. The light will remain on. The vehicle's engine may now be turned off. After 30 minutes the processor will recheck the level indicators. If a level indicator is observed for 1 minute, the AIR OPERATION indicator light will start flashing and the system will level the vehicle and return to the SLEEP MODE. This will continue until the system is turned off by pushing the "OFF" button or by releasing the park brake if the ignition is in the "ON" position.

EXCESS SLOPE: The system will attempt to level the vehicle for 15 minutes. After 15 minutes, if a LEVEL SENSING light is still on, the "EXCESS SLOPE" light will come on. The AIR OPERATION indicator light will be on steady, but the system will not go into the SLEEP MODE. Turn the system off.

NOTE: At any time the ignition switch is in the "ON" position and the panel is off, the vehicle may return to travel height.

OPERATING PROCEDURES

AIR OPERATION (Cont'd)

MANUAL AIR OPERATION

1. Place the transmission in the proper position for parking and set the park brake. The ignition key must be in the "ON" position to turn Air Leveling on. After the system is on, the ignition key can be turned to the "OFF" or "ACC" position without interrupting air leveling. Running the vehicle engine during air leveling is recommended. This will provide a better air supply for leveling. The vehicle will level with the engine shut off, however more time will be required for leveling.

NOTE: If the ignition key is in the "ON" position the panel will not turn on if the park brake is not set. The "NOT IN PARK/BRAKE" light will come on while the "AIR" button is being pushed.

2. Press the "AIR" button once to enter the air mode. The AIR OPERATION indicator light will glow steady. If the ignition is in the "ON" position, the four red WARNING lights on the panel will come on. This indicates that the height control valves have been locked out. The vehicle should not be moved when these lights are on.

3. The vehicle can now be leveled using the RAISE (up arrow) and LOWER (down arrow) buttons on the right of half of the panel in conjunction with the yellow LEVEL indicator lights. Any side to side leveling should be done before leveling the vehicle front to rear. Try leveling the vehicle by lowering the opposite side or end. If a level position is not achieved use the RAISE (up arrow) button to raise the low side or end. The yellow LEVEL indicator light indicates that side or end is low. When all yellow lights are out the vehicle is level.

NOTE: If the "DUMP" or "RAISE" buttons are pushed while manually leveling the vehicle with air, the system will shut off after the button is released.

4. Turn the ignition to the "OFF" position.

5. Turn the system off.

(DUMP) AND (RAISE) FUNCTIONS

The "DUMP" and "RAISE" functions are provided for operator convenience for purposes such as dumping the air suspension when parked in the wind, or raising or lowering the vehicle to avoid an obstacle.

IMPORTANT: The "DUMP" and "RAISE" features are momentary functions. The vehicle will raise or lower only while the buttons are being pushed. If the ignition is in the "ON" position, the suspension will return to travel height when the "DUMP" or "RAISE" button is released.

CAUTION: REREAD CAUTIONS ON THE FIRST PAGE OF THIS MANUAL. THE VEHICLE MAY DROP OR RAISE AND/OR MOVE FORWARD OR BACKWARD WITHOUT WARNING CAUSING INJURY OR DEATH.

IMPORTANT: DO NOT operate the vehicle over 5 M.P.H. unless the air suspension is at the proper height for travel.

The "DUMP" and "RAISE" buttons will operate with the ignition switch in any position, "ON", "OFF" or "ACC". The park brake does not have to be set. The "RAISE" button will not operate if the system is in the hydraulic mode. (See MANUAL HYDRAULIC OPERATION) If the system is in the air mode and the "RAISE" or "DUMP" button is pushed, the system will shut off when the button is released.

If desired for clearing an obstacle the vehicle may be moved while in the "RAISE" or "DUMP" mode.

DO NOT operate the vehicle over 5 M.P.H. or for extended distances unless the air suspension is at the proper height for travel.

Remember, the vehicle will return to travel height when the "RAISE" or "DUMP" button is released.

MAINTENANCE

OIL LEVEL

It is important that the four leveling jacks and all room extensions are fully retracted before checking the hydraulic oil level. To check the oil supply, remove the breather cap from the top of the hydraulic oil reservoir. The oil level should be approximately one inch below the top of the reservoir when adequately filled.

FLUID: HWH Specialty Hydraulic Oil is recommended. In an emergency Dexron automatic transmission fluid can be used.

NOTE: Dexron automatic transmission fluid contains red dye and can cause staining should a leak occur. **DO NOT USE** brake fluid or hydraulic jack fluid. Use of these can damage seals.

ELECTRICAL SYSTEM

The batteries should be in good condition and fully charged. Weak batteries can cause erratic operation. Battery cable terminals and battery posts and connections should be kept clean.

All electrical connections, especially ground connections, should be clean, tight, free from corrosion and protected from weathering.

UNUSUAL CONDITIONS

If driving conditions are unusually muddy, the jacks may become caked or clogged with mud. This condition may hamper the proper operation of the leveling system. This problem may be prevented or remedied by cleaning off each leveling jack if they become excessively muddy.

Do not move the vehicle while the leveling jacks are still in contact with the ground. Place the store levers in the store position and then visually check to see if the leveling jacks have returned to the STORE/TRAVEL position.

In wet or icy weather leveling jacks may become encrusted with ice. This may cause the leveling system to function improperly. To eliminate this problem, periodically check the leveling jacks and break loose any ice which may be causing improper operation.

NOTE : All major components of the system can be replaced with rebuilt jacks or can be sent to HWH CORPORATION to be rebuilt, when the system is out of warranty.

OPERATIONAL CHECK

Review the operator manual and run the system in the automatic and manual mode. Note any abnormal operation.

Check that all lights work according to the INDICATOR LIGHT section. Correct function of the four red WARNING lights is essential to the correct operation of the system.

Check that the vehicle is level when all the yellow LEVEL indicator lights are out.

NOTE : The level sensing unit has an accuracy tolerance of + or - 1 inch side to side, and + or - 5.4 inches front to rear on a 36 foot vehicle.

If the red LOW BATTERY indicator light comes on, the electrical system should be checked. If the light comes on, the operation of the system is not interrupted, but low voltage can cause erratic operation or damage components. Contact your dealer or HWH CORPORATION for assistance.

Check the air system by using the manual "DUMP" or "RAISE" buttons. If the system will not dump air, raise the vehicle or return to the proper travel height, contact your dealer or HWH CORPORATION.

Review the JACK RETRACTION Section.

Make sure the jacks will fully retract to the store position. Jacks should not interfere with any part of the vehicle when in the store position.

With the jacks extended, check that the jacks can be retracted using the "T" handles on the solenoid valves. Refer to the MANUAL JACK RETRACTION Section.

MAINTENANCE

LEVEL SENSING UNIT ADJUSTMENT

Level the vehicle by placing a circular bubble level in the center of the freezer floor or location within the vehicle that is to be level. With the vehicle level, adjust the sensing unit until all yellow lights are off. This is done by drawing up the corresponding screw if the sensing unit is mounted below the surface, as shown, or backing out the corresponding screw if the sensing unit is mounted above the surface. Bump the sensing unit to see that it has settled down in the level position.

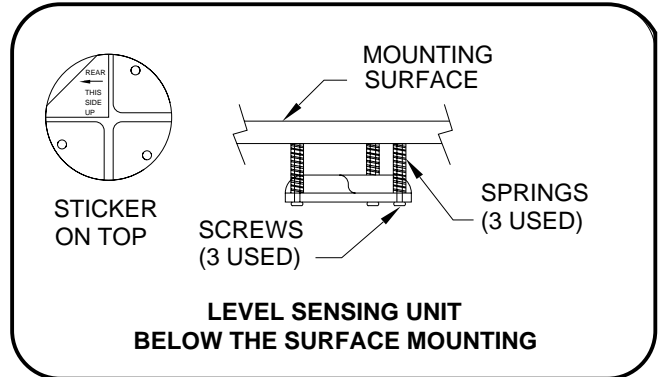

"NOT IN PARK/BRAKE" CHECK

CAUTION: WHEN MAKING THIS CHECK, BLOCK THE VEHICLES WHEELS SECURELY SO THE VEHICLE CANNOT ROLL FORWARD OR BACKWARD.

Set the park brake. Switch the ignition to the "ON" position. Press the "HYD" button one time. Release the parking brake

and confirm that the "NOT IN PARK/BRAKE" indicator light comes on. Reset the parking brake. The "NOT IN PARK/BRAKE" indicator light should go out. Switch the ignition to "OFF".

NOTE : If any of the above checks or inspections reveal a problem or if there are other problems or questions, consult a qualified RV repair center, your vehicle or coach manufacturer, or HWH CORPORATION (1-800-321-3494) for service or repair.

HYDRAULIC LINE CONNECTION DIAGRAM LEVELING SYSTEM



FRONT

NOTE: BEFORE OPERATING VALVE RELEASE "T" HANDLES, READ AND UNDERSTAND PROCEDURE FOR MANUAL JACK RETRACTION IN OPERATOR'S INSTRUCTIONS.

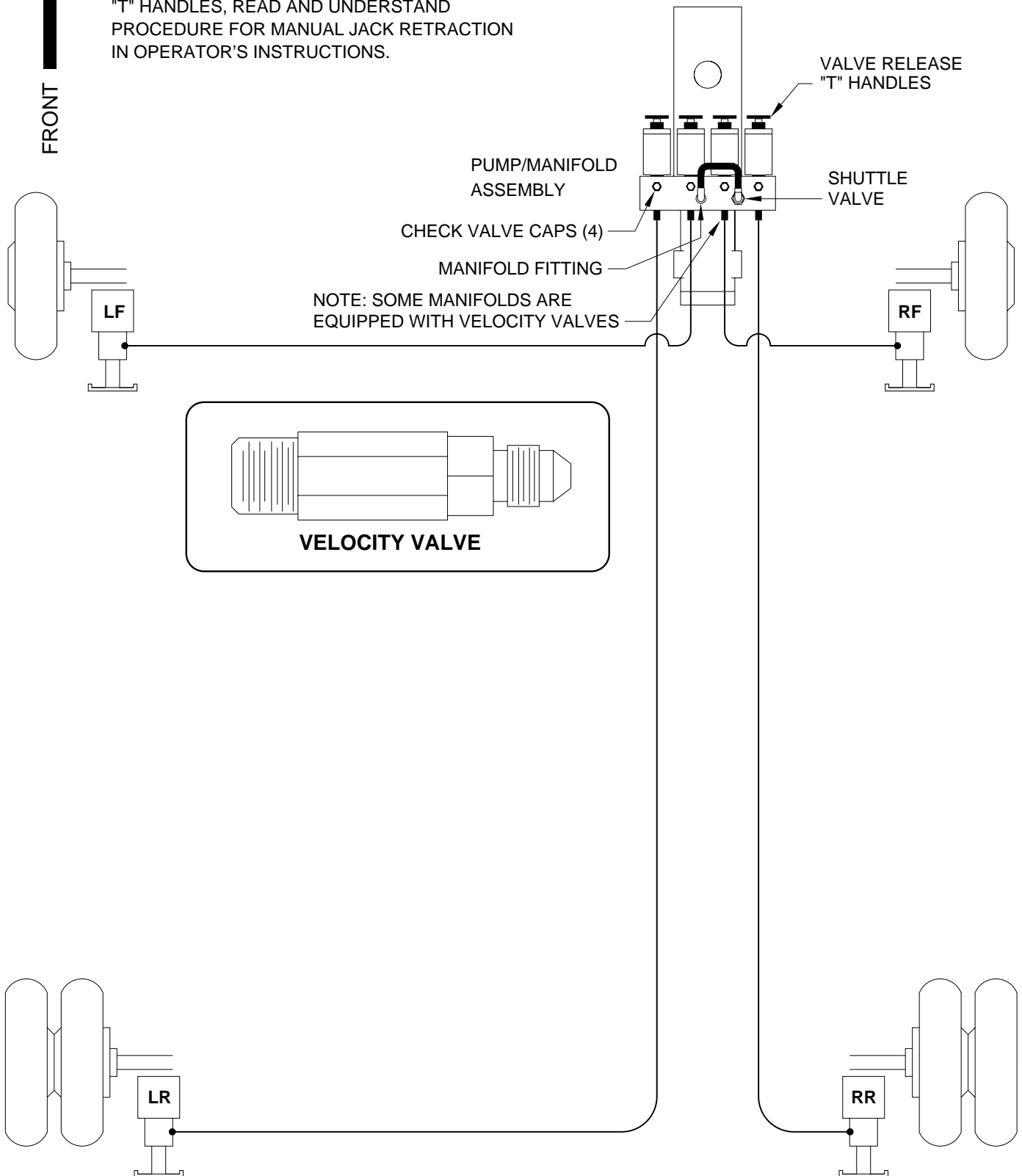

HYDRAULIC SCHEMATIC

BI-AXIS LEVELING WITH STRAIGHT-ACTING JACKS

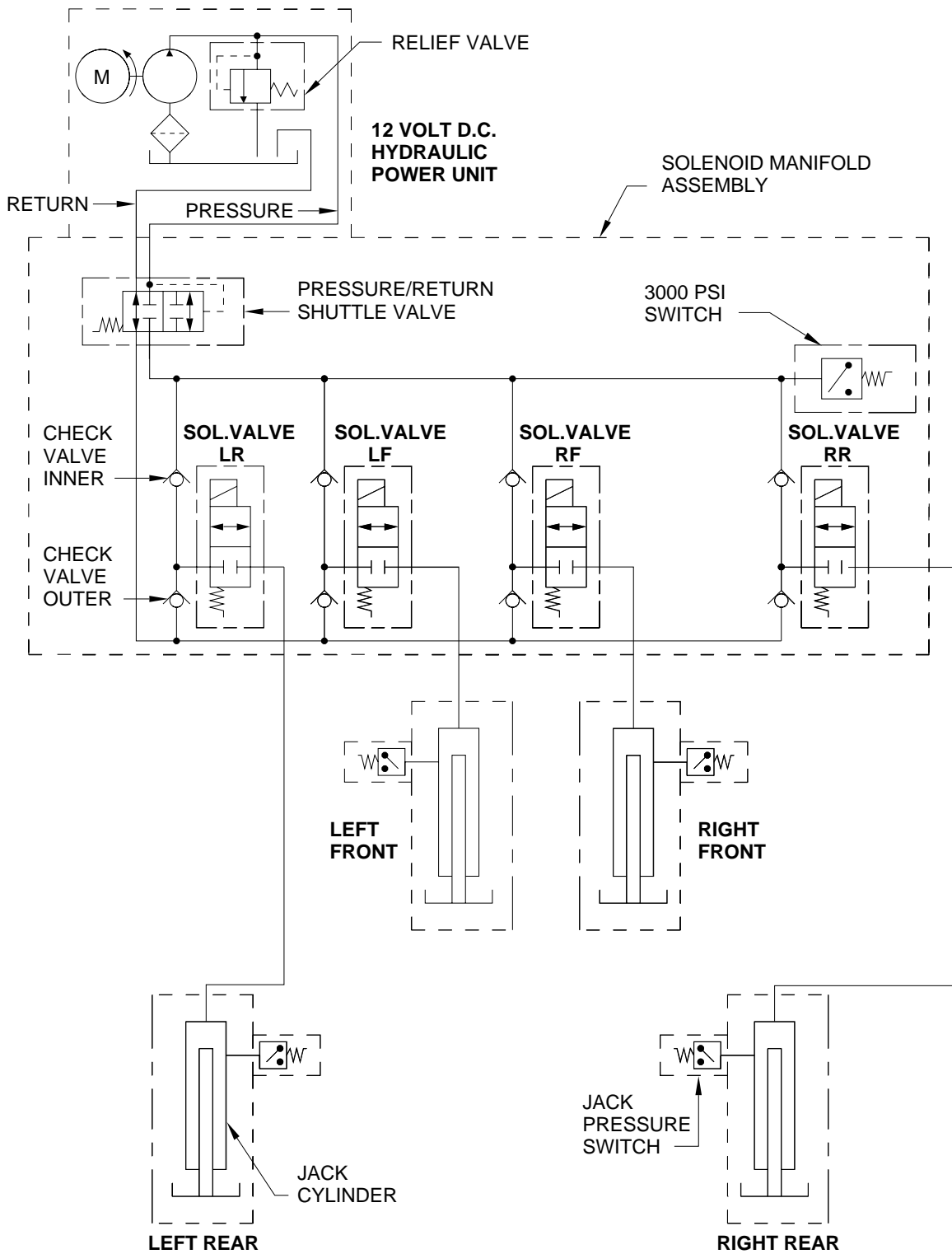

COMPRESSOR DIAGRAM

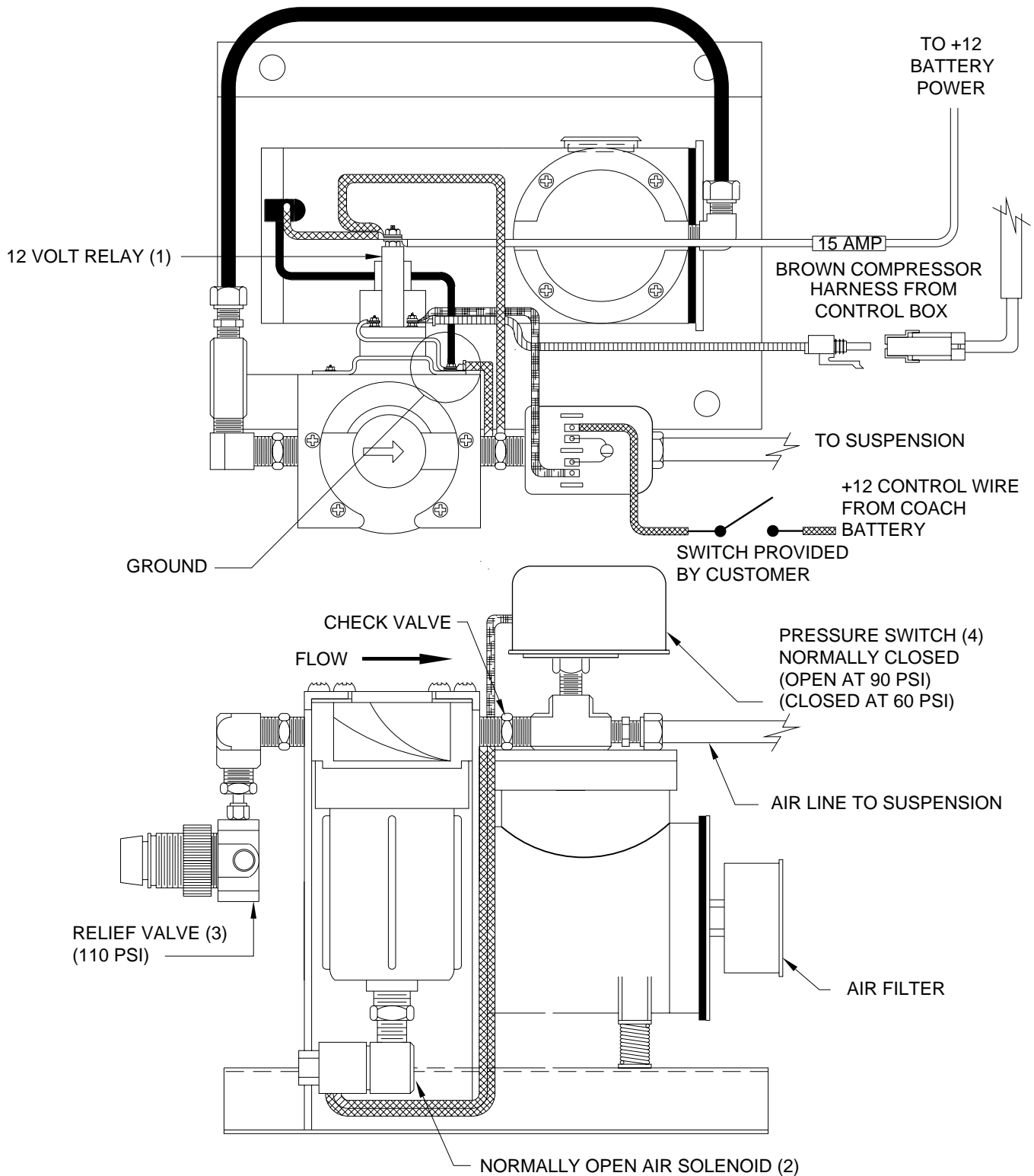

The control box sends a +12 signal to the 12 Volt Relay (1) whenever a raise function is needed in automatic or manual leveling. The compressor will run and the normally open air solenoid (2) will close allowing the compressor to build pressure. When the pressure builds to 110 psi the relief valve (3) will open and the compressor will continue to run. The pressure switch (4) will not affect the operation of the leveling system. During auxiliary operation of the compressor, when pressure builds to 90 psi the pressure switch will open, stopping the compressor. The air solenoid (2) will be open whenever the compressor is not running. This releases internal pressure from the compressor.

AIR SOLENOID MANIFOLD 6 VALVE WITH TWO PRESSURE SWITCHES

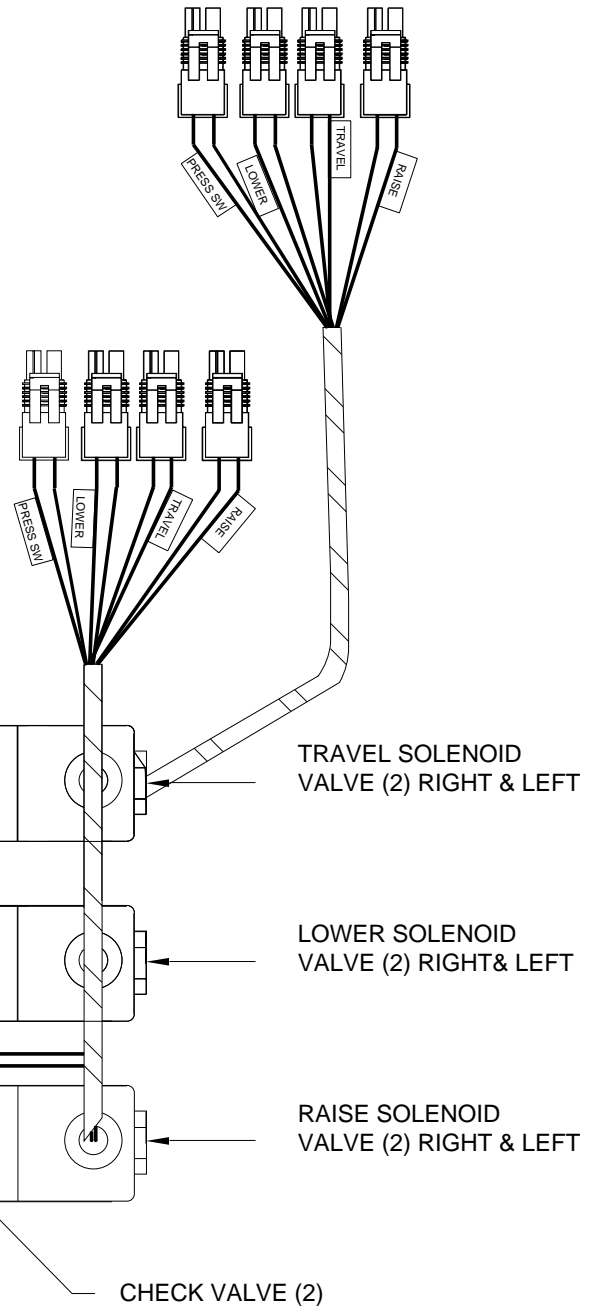
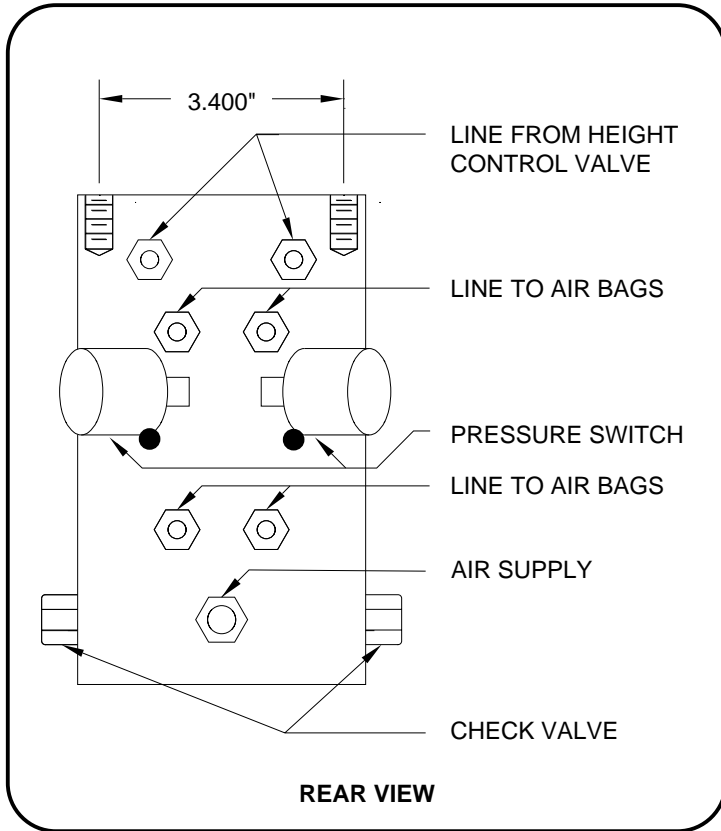

AIR LINE CONNECTION DIAGRAM

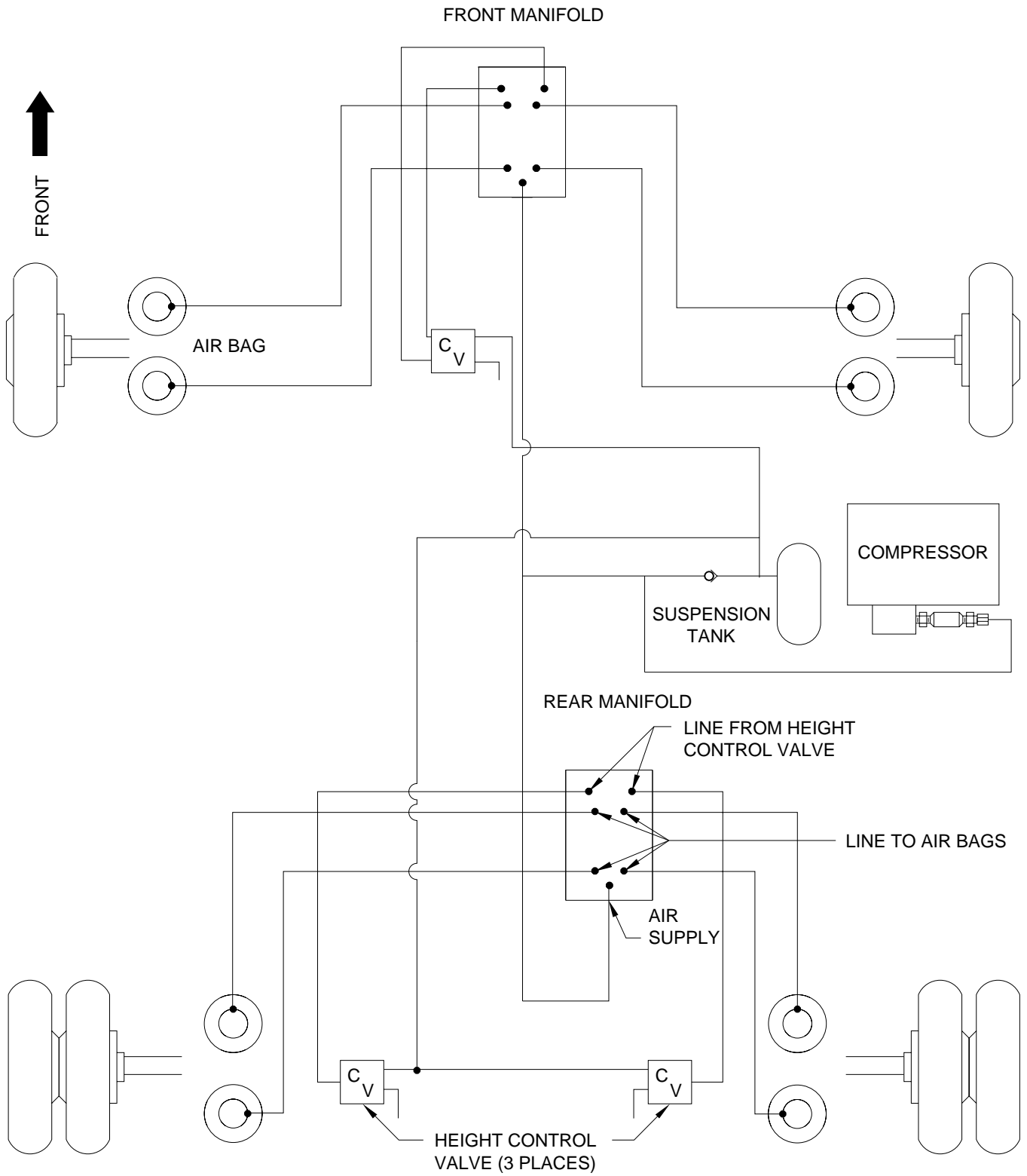

AIR LEVEL SCHEMATIC

4-POINT LEVELING W/AIR COMPRESSOR

PRESSURE SWITCHES FRONT AND REAR

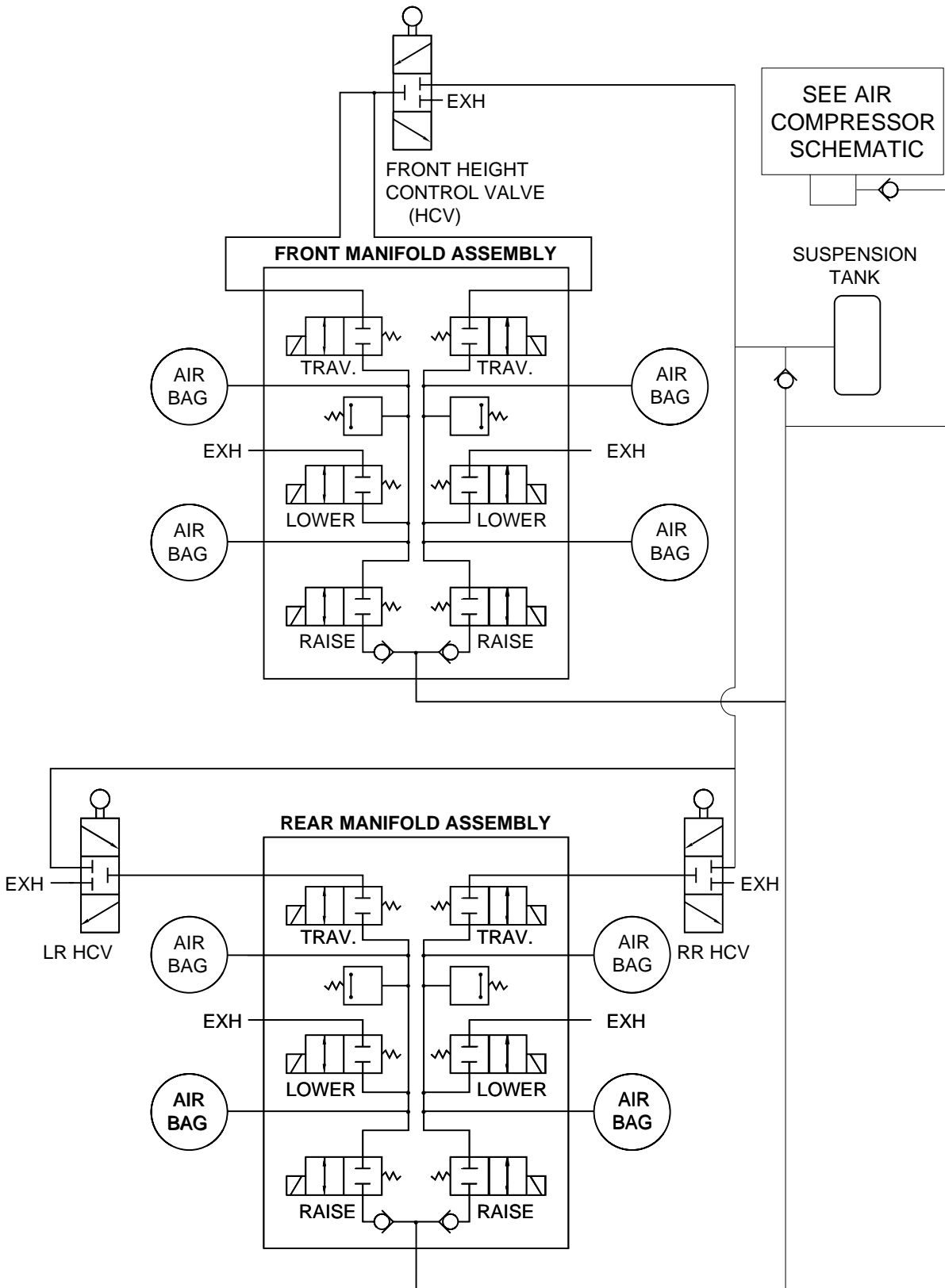

ELECTRICAL CONNECTION AIR LEVELING SYSTEM (WITH TOUCH PANEL CONTROL AND HYDRAULIC LEVELING)

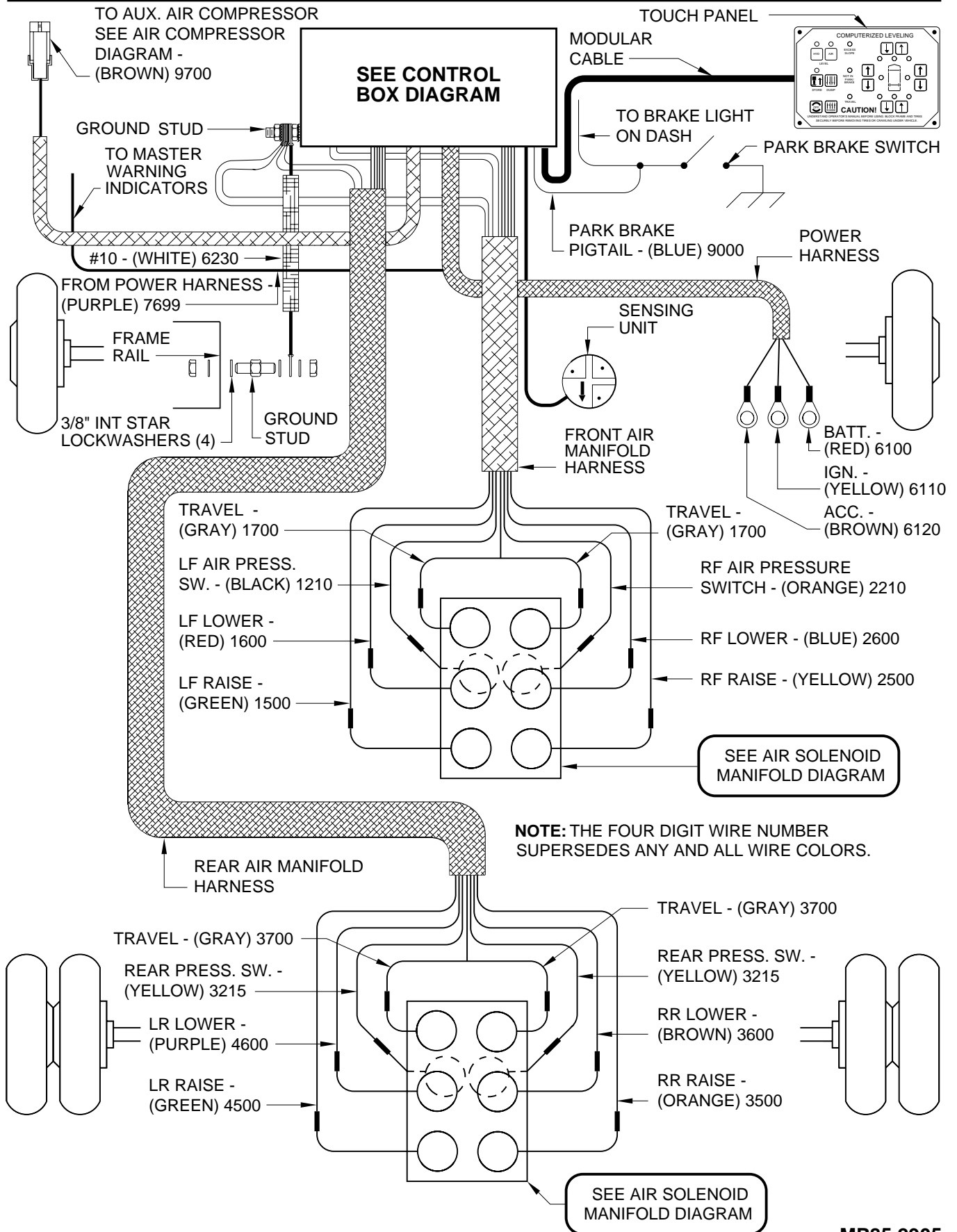

ELECTRICAL CONNECTION DIAGRAM HYDRAULIC LEVELING SYSTEM (WITH TOUCH PANEL CONTROL AND AIR LEVELING)

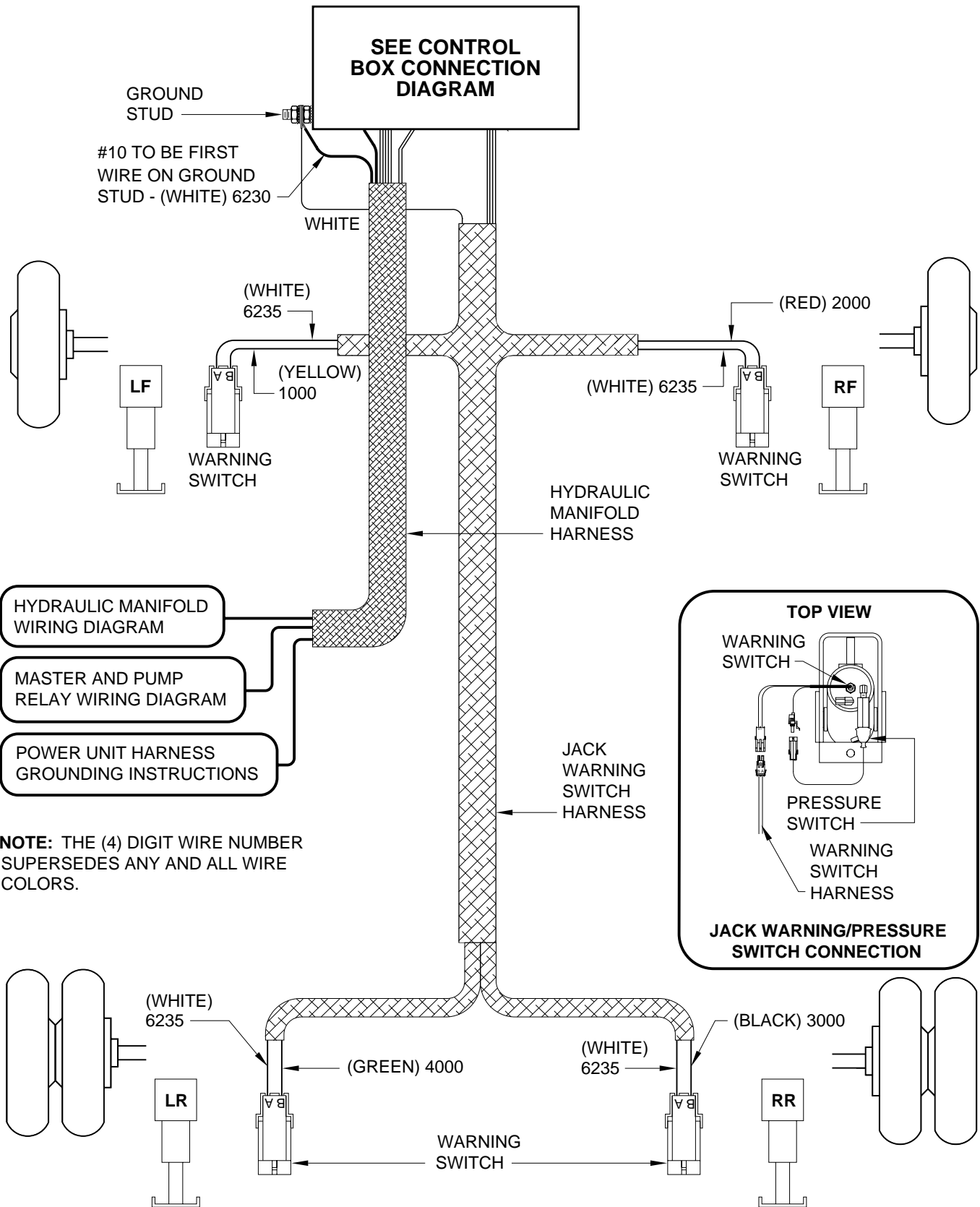

NOTE: THE (4) DIGIT WIRE NUMBER SUPERSEDES ANY AND ALL WIRE COLORS.

CONTROL BOX CONNECTION DIAGRAM

600 SERIES HYDRAULIC LEVELING/4-POINT AIR LEVELING

PART: SERIAL NUMBER STICKER

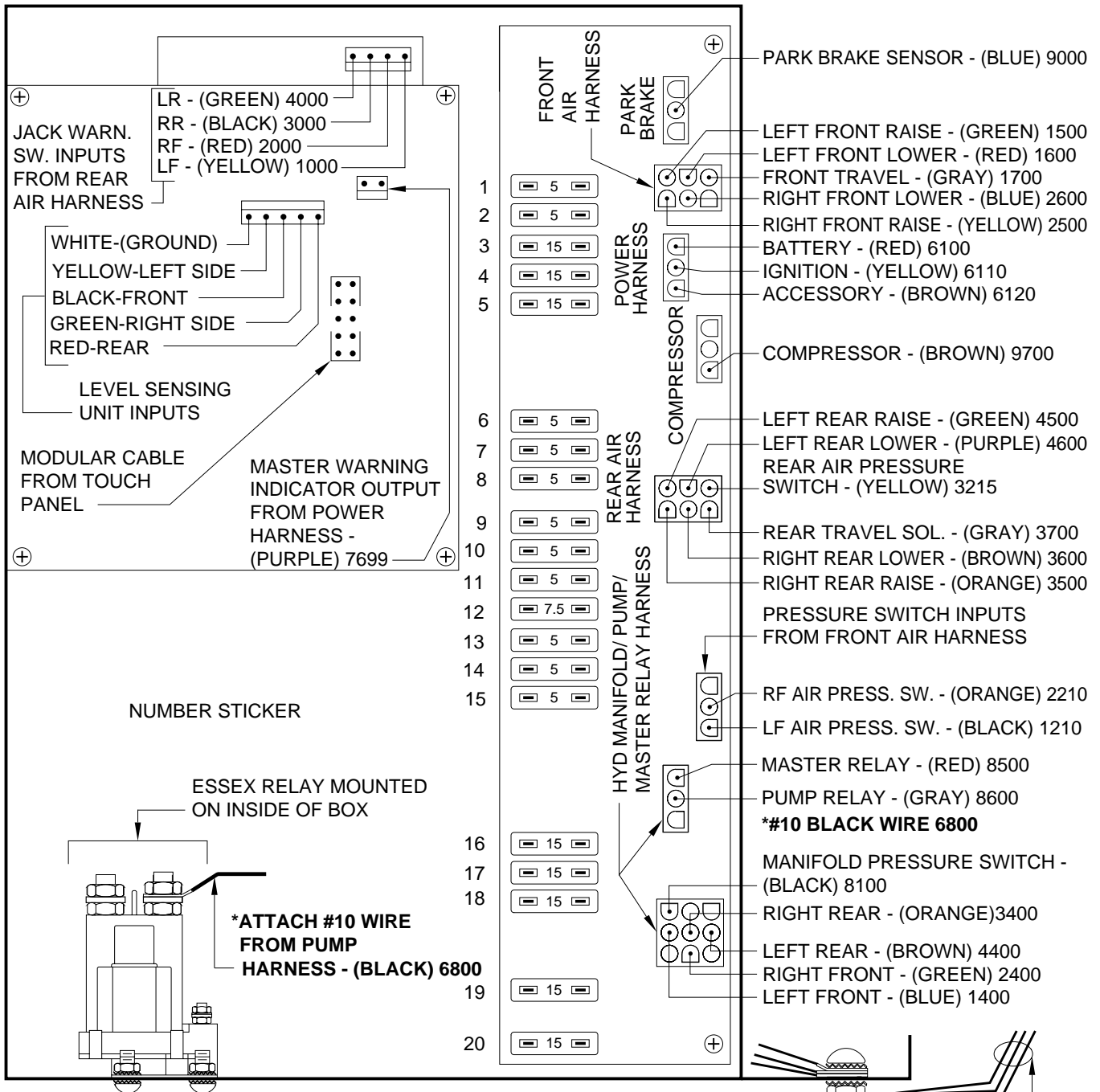

FUSE DESIGNATION

1 RIGHT FRONT LOWER	12 TRAVEL
2 RIGHT FRONT RAISE	13 N/A
3 BATTERY	14 MASTER RELAY
4 IGNITION	15 PUMP
5 ACC	16 RIGHT REAR SOLENOID
6 RIGHT REAR LOWER	17 N/A
7 LEFT REAR LOWER	18 LEFT FRONT SOLENOID
8 LEFT REAR RAISE	19 RIGHT FRONT SOLENOID
9 RIGHT REAR RAISE	20 LEFT REAR SOLENOID
10 LEFT FRONT RAISE	
11 LEFT FRONT LOWER	

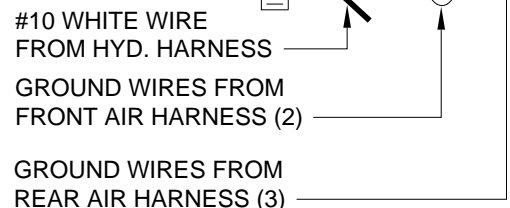

NOTE: THE FOUR DIGIT WIRE NUMBER SUPERSEDES ANY AND ALL WIRE COLORS.

WIRING DIAGRAM HYDRAULIC MANIFOLD FOR 610 SERIES LEVELING SYSTEMS

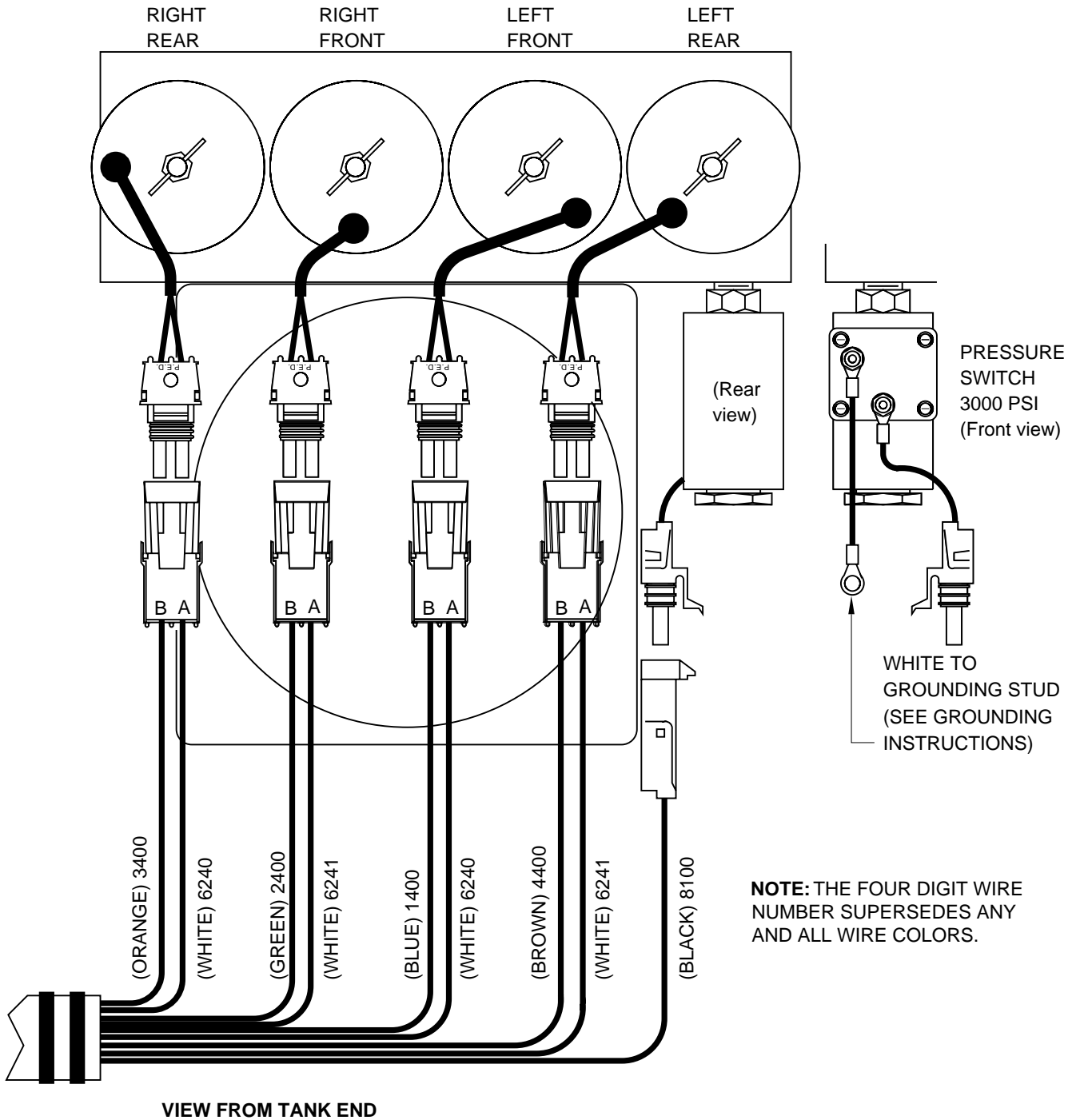

WIRING DIAGRAM MASTER AND PUMP RELAY

NOTE: THE FOUR DIGIT WIRE NUMBER
SUPERSEDES ANY AND ALL WIRE COLORS.

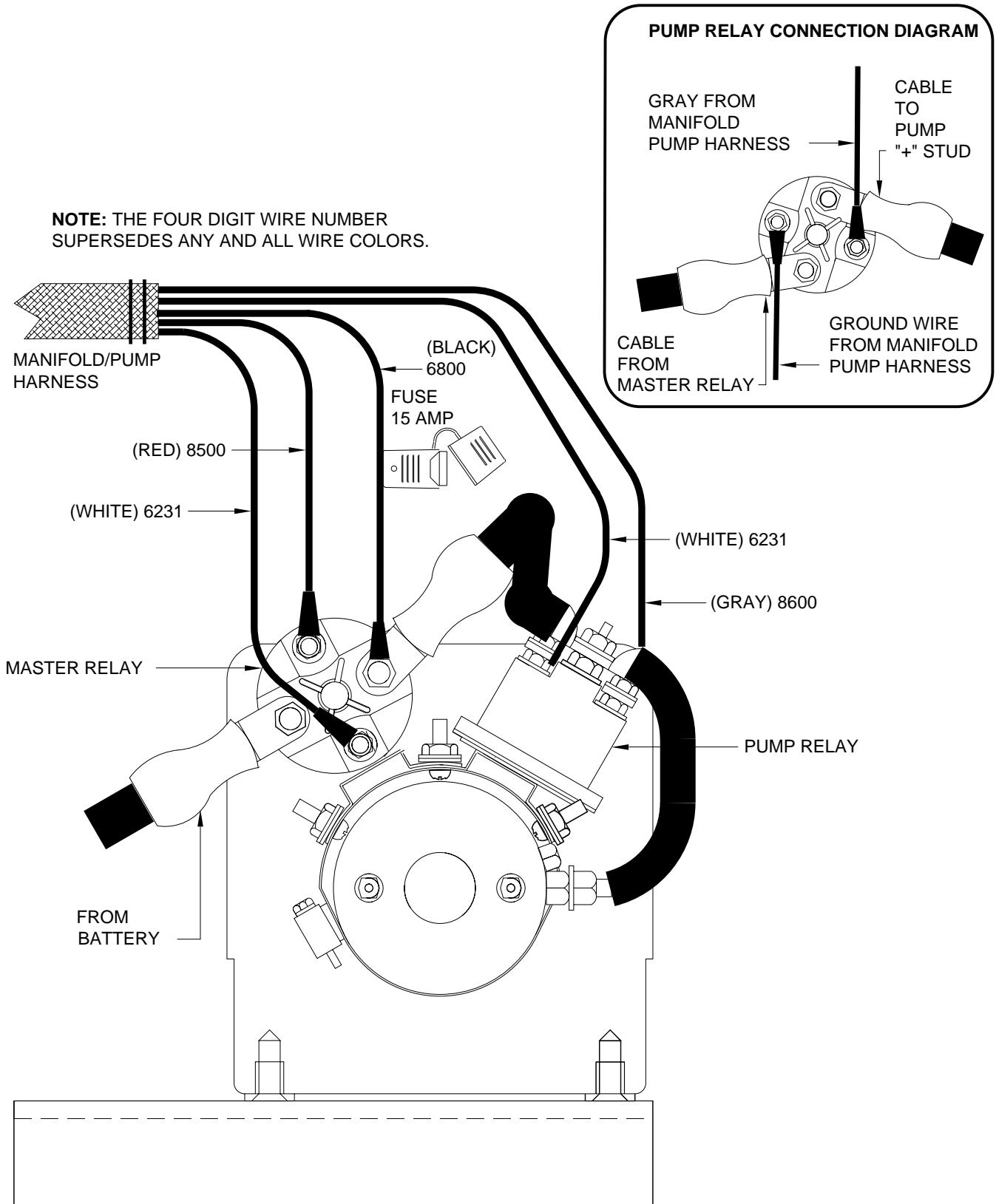

POWER UNIT/HARNESS GROUNDING INSTRUCTIONS

WELDED PUMP MOUNT

Use grounding stud and 3/8" internal star lockwashers as shown.

IMPORTANT: STAR LOCKWASHER MUST BE USED BETWEEN GROUNDING SURFACE AND WIRE TERMINALS

NOTE: THE FOUR DIGIT WIRE NUMBER SUPERSEDES ANY AND ALL WIRE COLORS.

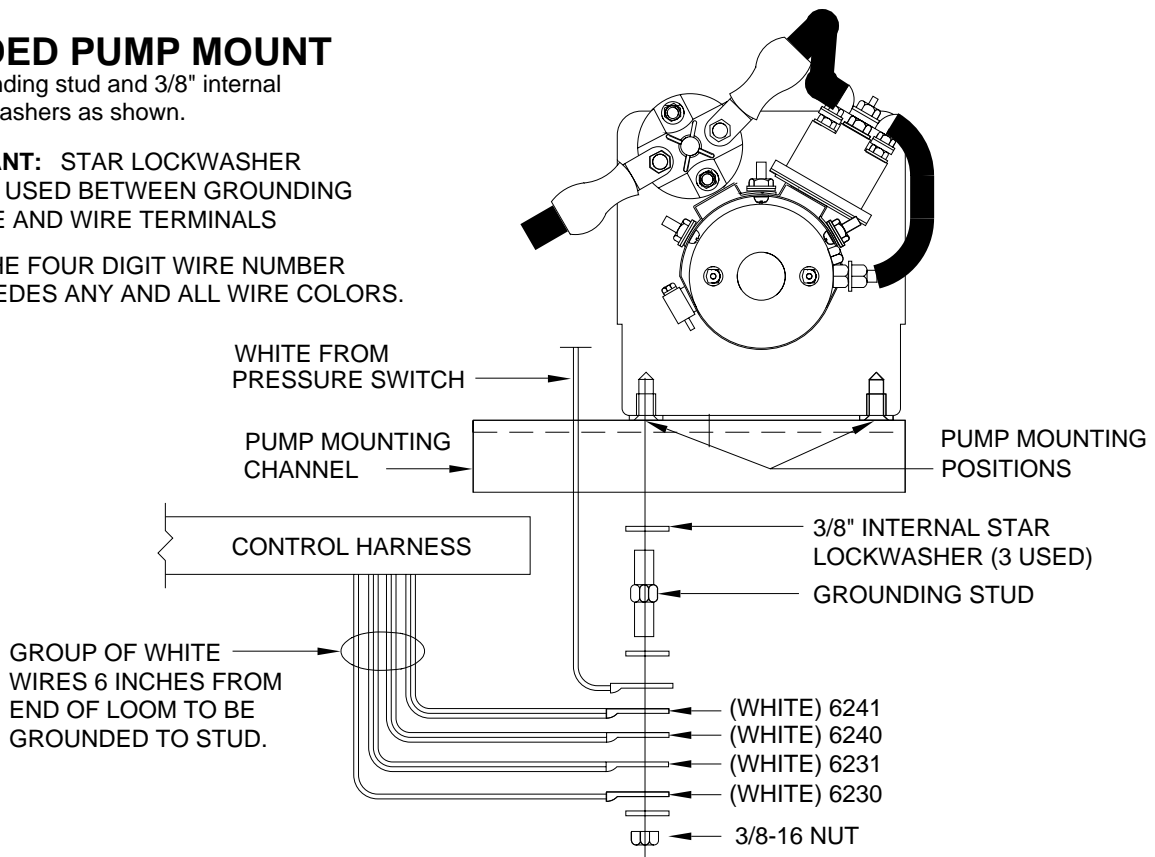

PUMP MOUNTED REMOTE FROM FRAME

Use grounding stud and 3/8" internal star lockwashers as shown.

IMPORTANT: STAR LOCKWASHER MUST BE USED BETWEEN GROUNDING SURFACE AND WIRE TERMINALS

NOTE: THE FOUR DIGIT WIRE NUMBER SUPERSEDES ANY AND ALL WIRE COLORS.

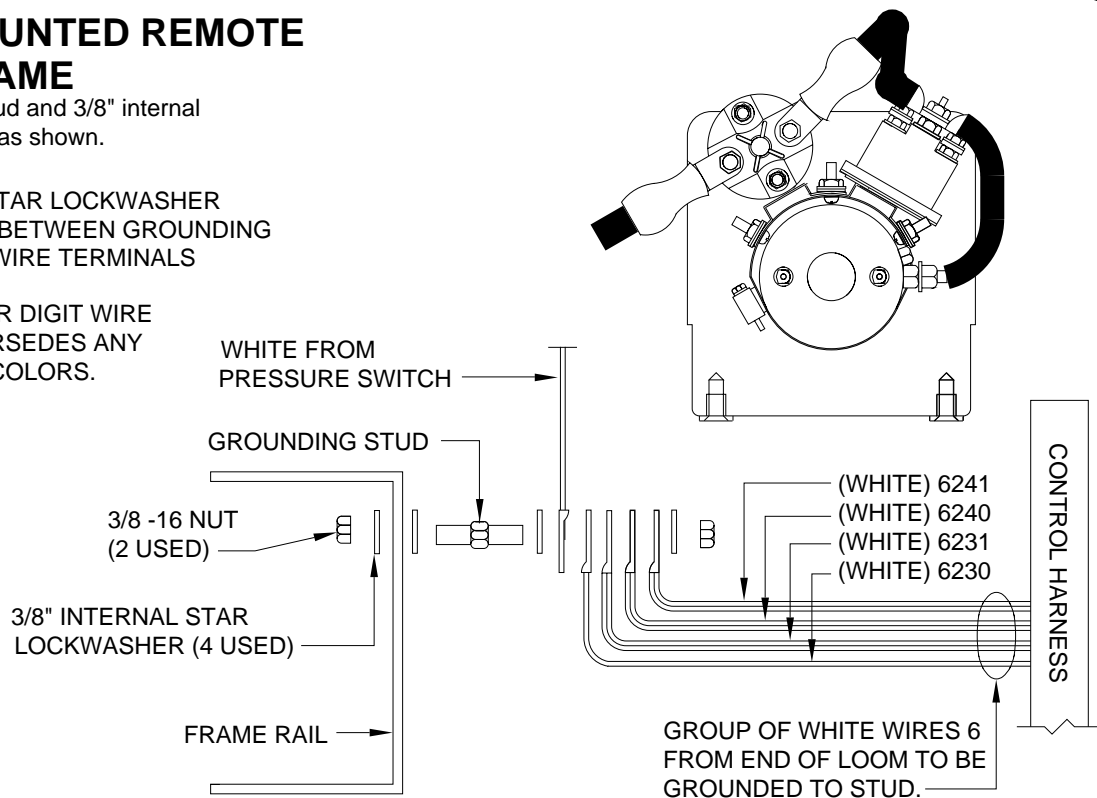

ELECTRICAL CONNECTION DIAGRAM FOR AIR COMPRESSORS WITH AUXILIARY SYSTEM PRESSURE SWITCH

