

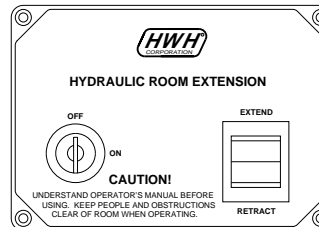

OPERATOR'S MANUAL

HWH® JOYSTICK-CONTROLLED 200 SERIES LEVELING SYSTEM and SPACEMAKER® ROOM EXTENSION SYSTEM

FEATURING:
Joystick BI-AXIS® Leveling Control
Hydraulic Leveling
Straight-Acting Jacks
Suspension Air Dump
Dual Cylinder "Rail" Room Extension (With Rack Sensing Valve)

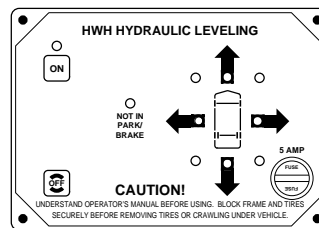
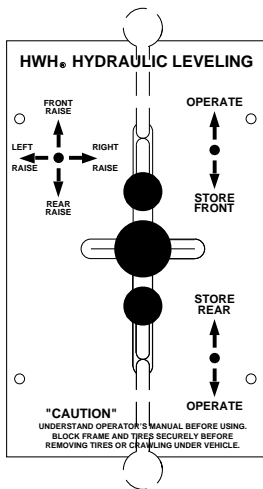

HWH CORPORATION
(On I-80, Exit 267 South)
2096 Moscow Road | Moscow, Iowa 52760
Ph: 800/321-3494 (or) 563/724-3396 | Fax: 563/724-3408
www.hwh.com

OPERATOR'S MANUAL

CAUTION !

READ THE ENTIRE OPERATOR'S MANUAL BEFORE OPERATING.

BLOCK FRAME AND TIRES SECURELY BEFORE CRAWLING UNDER VEHICLE. DO NOT USE LEVELING JACKS OR AIR SUSPENSION TO SUPPORT VEHICLE WHILE UNDER VEHICLE OR CHANGING TIRES. VEHICLE MAY DROP AND/OR MOVE FORWARD OR BACKWARD WITHOUT WARNING CAUSING INJURY OR DEATH.

KEEP ALL PEOPLE CLEAR OF VEHICLE WHILE LEVELING SYSTEM AND ROOM EXTENSION ARE BEING OPERATED. KEEP PEOPLE AND OBSTRUCTIONS CLEAR OF ROOM WHEN OPERATING.

THE JACKS MAY ABRUPTLY SWING UP WHEN THE FOOT CLEARS THE GROUND OR WHEN JACK REACHES FULL EXTENSION.

NEVER PLACE HANDS OR OTHER PARTS OF THE BODY NEAR HYDRAULIC LEAKS. OIL MAY PENETRATE SKIN CAUSING INJURY OR DEATH.

WEAR SAFETY GLASSES WHEN INSPECTING OR SERVICING THE SYSTEM TO PROTECT EYES FROM DIRT, METAL CHIPS, OIL LEAKS, ETC. FOLLOW ALL OTHER APPLICABLE SHOP SAFETY PRACTICES.

DO NOT OVER EXTEND THE REAR JACKS. IF THE WEIGHT OF THE VEHICLE IS REMOVED FROM ONE OR BOTH REAR WHEELS, THE VEHICLE MAY ROLL FORWARD OR BACKWARD, OFF THE JACKS.

NOTE: KEEP THE CONTROL VALVE LEVERS IN THE STORE POSITION WHEN JACKS ARE NOT IN USE.

IMPORTANT: IF VEHICLE IS EQUIPPED WITH A ROOM EXTENSION, READ ROOM EXTENSION SECTION BEFORE OPERATING LEVELING SYSTEM.

HOW TO OBTAIN WARRANTY SERVICE

THIS IS NOT TO BE INTERPRETED AS A STATEMENT OF WARRANTY

HWH CORPORATION strives to maintain the highest level of customer satisfaction. Therefore, if you discover a defect or problem, please do the following:

FIRST: Notify the dealership where you purchased the vehicle or had the leveling system installed. Dealership management people are in the best position to resolve the problem quickly. If the dealer has difficulty solving the problem, he should immediately contact the Customer Service Department, at HWH CORPORATION.

SECOND: If your dealer cannot or will not solve the problem, notify the Customer Service Department:
HWH CORPORATION 2096 Moscow Rd. Moscow IA. 52760
(563) 724-3396 OR (800) 321-3494. Give your name and address, coach manufacturer and model year, date the coach was purchased, or the date of system installation,

description of the problem, and where you can be reached during business hours (8:00 a.m. till 5:00 p.m. c.s.t.). HWH CORPORATION personnel will contact you to determine whether or not your claim is valid. If it is, HWH CORPORATION will authorize repair or replacement of the defective part, either by appointment at the factory or by the authorization of an independent service facility, to be determined by HWH CORPORATION. All warranty repairs must be performed by an independent service facility authorized by HWH CORPORATION, or at the HWH CORPORATION factory, unless prior written approval has been obtained from proper HWH CORPORATION personnel.

CONTROL IDENTIFICATION

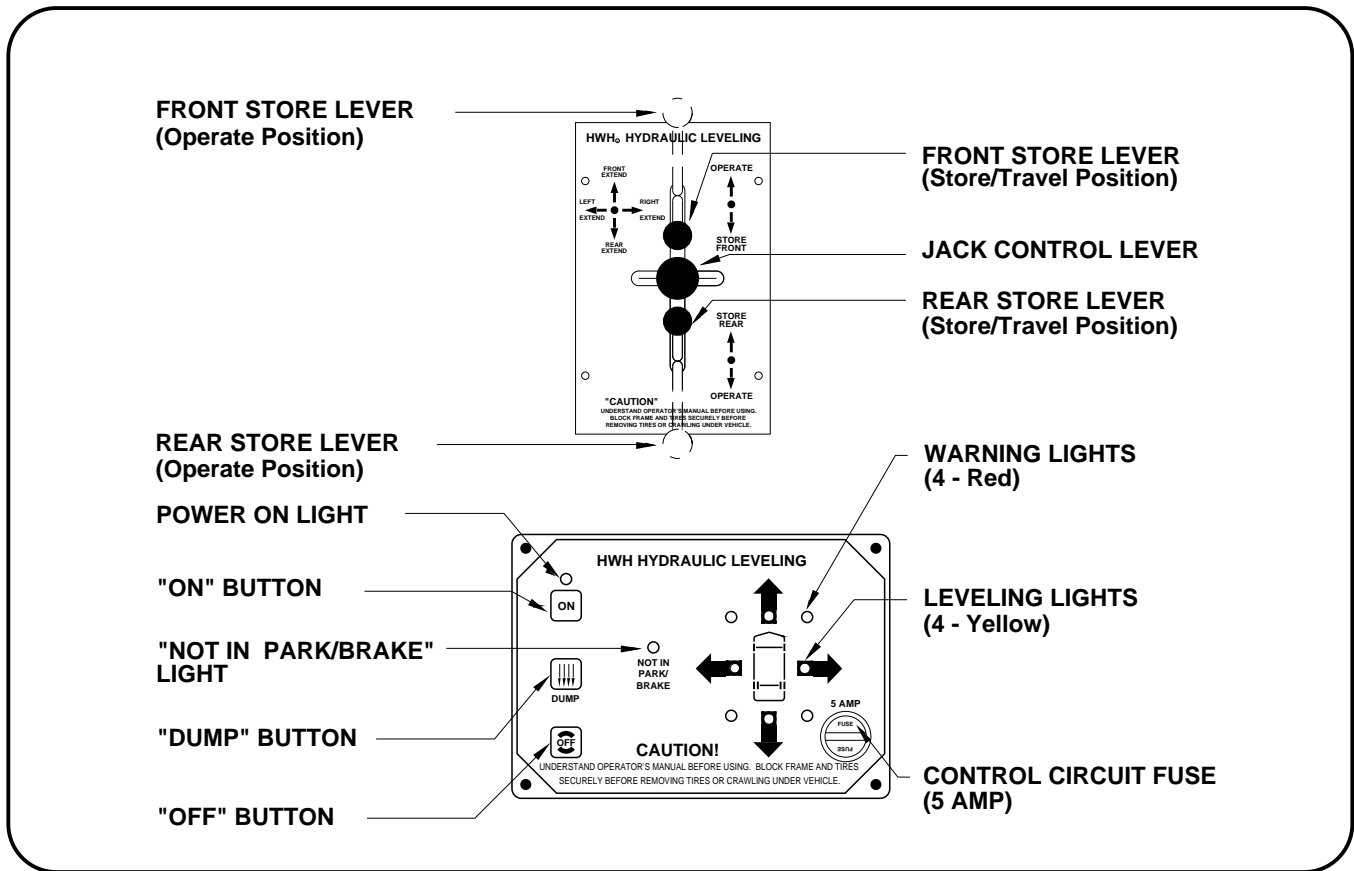

CONTROL FUNCTIONS

CONTROL BUTTONS

"ON" BUTTON : This is the "ON" button for the leveling system. It provides control power to operate the electrical relay on the pump, the LEVELING lights and the 4 red WARNING lights. It does not control power to the master "JACKS DOWN" warning light or buzzer.

"OFF" BUTTON : This button turns off power to the leveling system but not the master WARNING light and buzzer.

STORE LEVERS : These two levers are used to retract the jacks into the STORE/TRAVEL position. They must be in the operate position for leveling.

JACK CONTROL LEVER : Jacks are extended in pairs by pushing the jack control lever to one of the EXTEND positions. This movement of the lever activates the pump and directs hydraulic fluid to the jacks. When the lever is released it will return to the neutral (center) position, turning off the pump and stopping jacks in position.

"DUMP" BUTTON : This button will dump air from the suspension system only when the panel is on.

INDICATOR LIGHTS

POWER ON LIGHT : This light indicates the system is on.

"NOT IN PARK/BRAKE" LIGHT : This indicator light is on when the "ON" button is pushed, but the hand/auto park brake is not set. The panel will not turn on.

LEVELING LIGHTS : If a yellow LEVELING light is on, that indicates a side or end of the vehicle is low. Extend the appropriate jack pairs to put out the yellow light. Only one yellow LEVELING light should be on at a time. The vehicle is level when all yellow lights are out.

WARNING LIGHTS: A red WARNING light will be on whenever the corresponding jack is extended 2 inches or more provided the ignition switch is in the "ACC" or "ON" position and the panel is on. Some vehicles are equipped with a dashmounted master "JACKS DOWN" light which will be on when one or more jacks are extended 2 inches or more, provided the ignition switch is "ON".

WARNING BUZZER : A buzzer will sound if a jack is extended 2 inches or more and the ignition switch is "ON".

CONTROL IDENTIFICATION

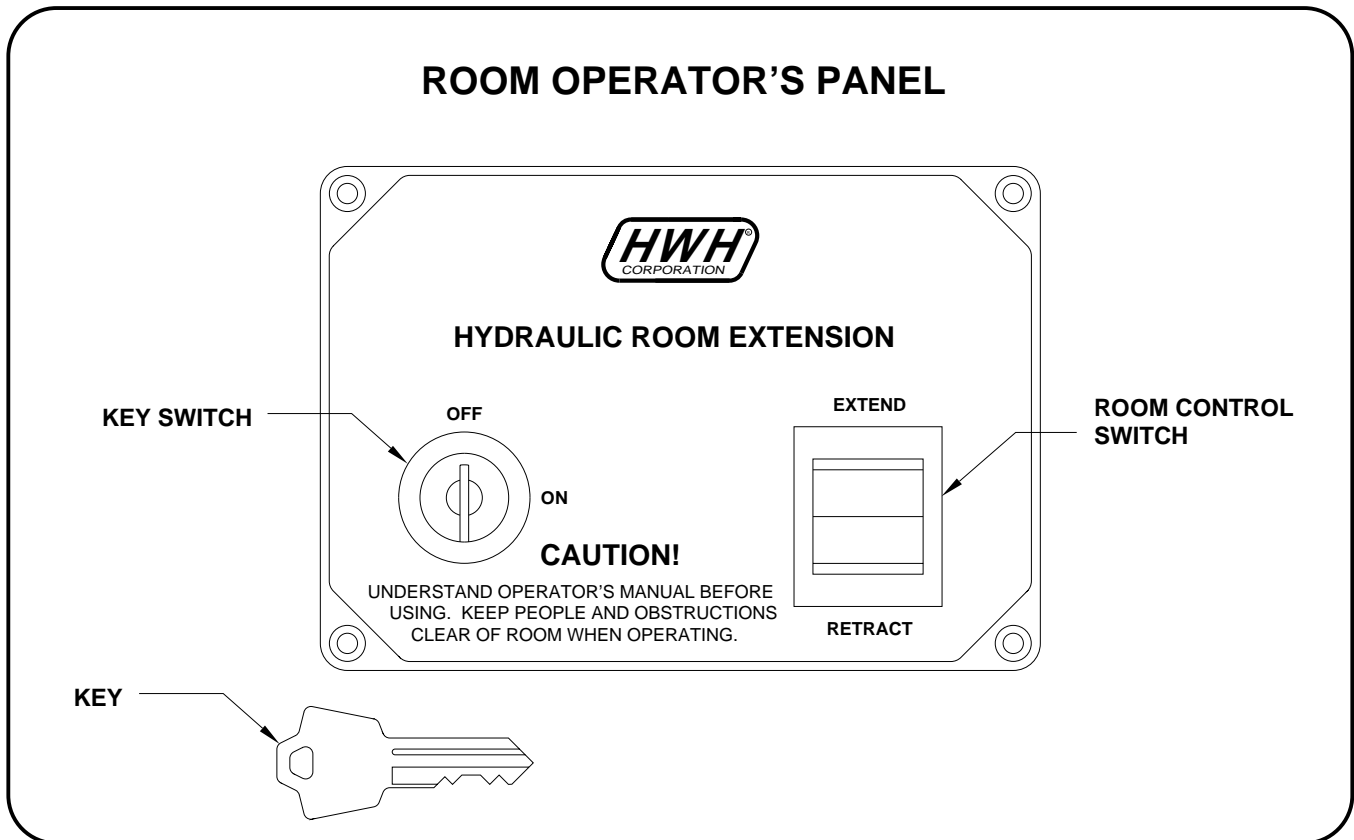

CONTROL FUNCTIONS

KEY SWITCH: The KEY SWITCH controls power to the ROOM CONTROL SWITCH. When the KEY SWITCH is in the "ON" POSITION the room can be operated, and the key cannot be removed. When the KEY SWITCH is in the "OFF" position the room cannot be operated, and the key can be removed.

ROOM CONTROL SWITCH: The ROOM CONTROL SWITCH is a two position momentary switch. Pressing the switch in the EXTEND POSITION will extend the room. Pressing the switch in the RETRACT POSITION will retract the room. Releasing the ROOM CONTROL SWITCH will halt the operation of the room.

OPERATING PROCEDURES

SITE SELECTION

Maintain adequate clearance in all directions for vehicle, room extensions, awnings, doors, steps ect. Vehicle may move in any direction due to jack extending or retracting,

settling of jacks or vehicle, equipment malfunction etc. If parking on soft ground or asphalt paving, wood blocks or pads should be placed under the jacks.

ROOM EXTENSION PROCEDURES

IMPORTANT: If the vehicle is equipped with a room extension read this section carefully.

Refer to the vehicle owner's manual for proper operation of room extensions.

If the vehicle is equipped with kick-down jacks, the wheels **MUST** be blocked securely. Do **NOT** operate any room extension until the leveling and stabilizing procedure is complete. Do **NOT** retract the leveling system until all room extensions are retracted. **NEVER** operate the leveling system when any room extensions are extended.

IMPORTANT: Do not use a room extension support when the vehicle is supported by the leveling system.

LEVELING PROCEDURE

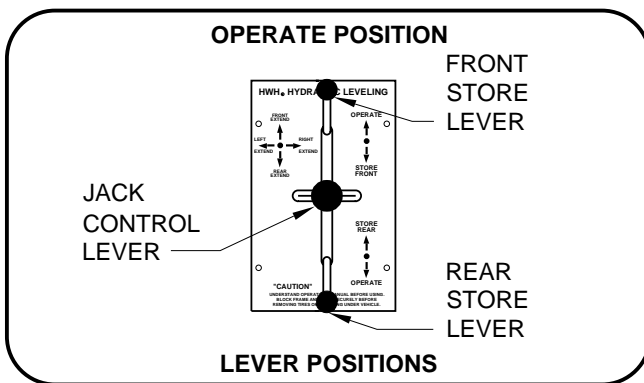

5. Move the FRONT and REAR STORE LEVERS to the OPERATE POSITION. Nothing should happen at this time. Place pads under jacks if necessary at this time.

NOTE: The respective RED WARNING LIGHT will come on when a jack is extended 2 or more inches.

6. A lit yellow LEVEL light indicates that the end, side or corner of the vehicle is low. Only one yellow LEVEL light should be lit at a time. If a corner of the vehicle is low a side LEVEL light will be on by itself.

Move the JACK CONTROL LEVER to the EXTEND position to extend jack pairs corresponding to a lit yellow light. Extend jack pairs accordingly until all yellow lights are out. It may take several movements from side to front, or side to rear to raise a low corner. If the ground is too uneven, the jacks may not have enough stroke to level the vehicle. The vehicle may have to be moved.

7. After the vehicle is level, the jacks not used for leveling may be extended until they touch the ground. This provides additional stability against wind and activity in the vehicle. Do this by pushing the jack control lever to the rear and/or front as needed to extend any remaining jacks. Do not use the right or the left extend positions. Jacks used to stabilize the vehicle should lift the vehicle 3/4" to 1" after touching the ground.

8. Push the "OFF" button on the light panel.

9. Turn the ignition switch off.

NOTE: The leveling system should be cycled once a month or whenever the vehicle is used, to keep the system in operating condition.

1. Place gear selector in the parking position, apply park brake and block tires securely.

NOTE: If the hand/auto park brake is not set, the "NOT IN PARK/BRAKE" light will come on while the "ON" button is pushed. The panel will not turn on if the park brake is not set.

2. Place the ignition switch in the "ACC" position. The vehicle's engine must be off. Running the engine during or after leveling may inflate the air suspension lifting the vehicle out of level.

3. Push the "ON" button on the light plate. The POWER ON light will be lit.

4. Push and hold the "DUMP" button until all air is exhausted from the vehicle's suspension system.

OPERATING PROCEDURES

ROOM EXTEND PROCEDURE

CAUTION: OPERATING THE ROOM WITH ANY ROOM-LOCKING DEVICES LOCKED OR THE MANUAL-RETRACT WINCH ATTACHED CAN CAUSE PERSONAL INJURY AND VEHICLE DAMAGE. IT IS THE OPERATOR'S RESPONSIBILITY TO ENSURE THAT ALL ROOM-LOCKING DEVICES AND THE MANUAL-RETRACT WINCH ARE DISENGAGED BEFORE OPERATING THE ROOM.

IMPORTANT: It is recommended to level and stabilize the vehicle before extending the room.

IMPORTANT: Extending or retracting any leveling jacks when the room is extended is not recommended.

1. Follow the LEVELING AND STABILIZING PROCEDURE.
2. Unlock all room-locking devices.

NOTE: If the MANUAL RETRACT WINCH is attached to the room remove it before extending the room.

CAUTION: KEEP PEOPLE AND OBSTRUCTIONS CLEAR OF ROOM WHEN OPERATING.

NOTE: Make sure there is adequate clearance to fully extend the room.

3. Turn the ignition switch to ACCESSORY.
4. Press the "ON" button on the leveling system control panel if the POWER ON LIGHT is not illuminated.
5. Insert the KEY and turn the KEY SWITCH to the "ON" position.

6. To extend the room, press and hold the ROOM CONTROL SWITCH in the "EXTEND" position until the room is fully extended.

NOTE: Hold the switch to "EXTEND" three or four seconds after the room is fully extended. This assures proper pressurization of the cylinders. **During normal operation of the room, do not reverse direction of the room until the room is fully extended. If necessary, the direction of the room may be reversed, but watch for binding of the room. If the direction of the room has been reversed, DO NOT re-extend the room until the room has been fully retracted.**

IMPORTANT: Do not hold the ROOM CONTROL SWITCH in the "EXTEND" position for more than ten seconds after the room is fully extended or stops moving. **If either side of the room stops moving, release the room control switch immediately. DO NOT force the room. DO NOT reverse direction of the room, contact HWH Customer Service for assistance 1-800-321-3494.**

NOTE: Releasing the ROOM CONTROL SWITCH will halt the operation of the room.

7. Turn the KEY SWITCH to the "OFF" position and remove the key to prevent undesired operation of the room.
8. Press the "OFF" button on the leveling system control panel.
9. Turn off the ignition switch.

IMPORTANT: Do not use the room extension support when the vehicle is supported by the leveling system.

OPERATING PROCEDURES

ROOM RETRACT PROCEDURE

CAUTION: KEEP PEOPLE AND OBSTRUCTIONS CLEAR OF ROOM WHEN OPERATING.

IMPORTANT: Extending or retracting any leveling jacks when the room is extended is not recommended.

1. Insert the KEY and turn the KEY SWITCH on the ROOM OPERATOR'S PANEL to the "ON" position.

2. To retract the room press and hold the ROOM CONTROL SWITCH in the "RETRACT" position until the room is fully retracted.

NOTE: Hold the switch to "RETRACT" three or four seconds after the room is fully retracted. This assures proper pressurization of the cylinders. **During normal operation of the room, do not reverse direction of the room until the room is fully retracted. If necessary, the direction of the room may be reversed, but watch for binding of the room. If the direction of the room has been reversed, DO NOT retract the room until the room has been fully extended.**

IMPORTANT: Do not hold the ROOM CONTROL SWITCH in the "RETRACT" position for more than ten seconds after the room is fully retracted or stops moving.

If either side of the room stops moving, release the room control switch immediately. DO NOT force the room. DO NOT reverse direction of the room, contact HWH Customer Service for assistance 1-800-321-3494.

NOTE: Releasing the ROOM CONTROL SWITCH will halt the operation of the room.

3. Turn the KEY SWITCH on the ROOM OPERATOR'S PANEL to the "OFF" position.

4. Remove the KEY to prevent undesired operation of the room.

5. Engage all room locking devices.

6. If the room will not retract see the MANUAL ROOM RETRACT PROCEDURE.

IMPORTANT: Room-locking devices should be locked while traveling.

OPERATING PROCEDURES

LEVELING SYSTEM RETRACT PROCEDURE

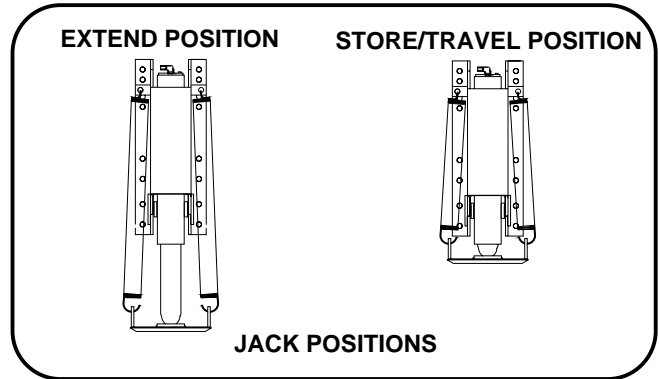
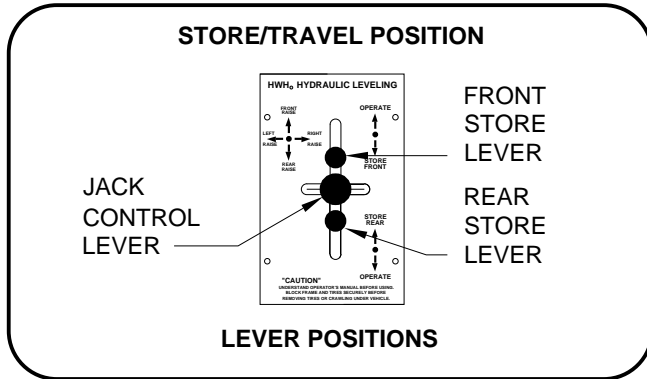

IMPORTANT: Do not retract the jacks while the room is extended.

CAUTION: MAKE SURE THAT PEOPLE AND EQUIPMENT ARE CLEAR OF THE VEHICLE.

IMPORTANT: Always retract the front jacks first.

1. To retract the jacks move the FRONT STORE LEVER and the REAR STORE LEVER to the STORE/TRAVEL POSITION.

CAUTION: THE STORE LEVERS SHOULD BE KEPT IN THE "STORE" POSITION WHILE TRAVELING TO KEEP THE JACKS IN THE STORE/TRAVEL POSITION.

2. Visually check that each jack is in its STORE/TRAVEL POSITION.

NOTE : With all jacks in the STORE/TRAVEL POSITION, the ignition switch ON or in ACCESSORY, and the POWER ON LIGHT illuminated the following should be off: all the WARNING LIGHTS, the "JACKS DOWN" LIGHT, and the WARNING BUZZER.

CAUTION: DO NOT MOVE THE VEHICLE WHILE ANY JACKS ARE EXTENDED. THIS VEHICLE IS EQUIPPED WITH STRAIGHT-ACTING JACKS. MOVING THE VEHICLE WITH THE JACKS EXTENDED CAN CAUSE SEVERE DAMAGE TO THE JACKS AND THE VEHICLE AND CAN CREATE A DRIVING HAZARD. DO NOT RELY SOLELY UPON THE WARNING LIGHTS, THE "JACKS DOWN" LIGHT, OR THE WARNING BUZZER AS AN INDICATION THAT ALL THE JACKS ARE IN THE STORE/TRAVEL POSITION.

3. Press the "OFF" BUTTON.

4. Start the vehicle engine and let air pressure build up in the suspension.

5. Turn the ignition switch OFF or proceed to travel.

MANUAL ROOM RETRACT PROCEDURE
USE ONLY WHEN ROOM CANNOT BE RETRACTED WITH THE ROOM CONTROL SWITCH OR THE MANUAL RETRACT WINCH.
THIS SHOULD BE DONE BY A CERTIFIED TECHNICIAN ONLY.
CONTACT HWH CORPORATION FOR ASSISTANCE AT (1-800-321-3494).

When extending or retracting the room, if one side of the room does not move, release the room control switch immediately. The rack sensing valve plunger (1, FIGURE 1) may be stuck, bent or not touching the strike plate (2, FIGURE 1).

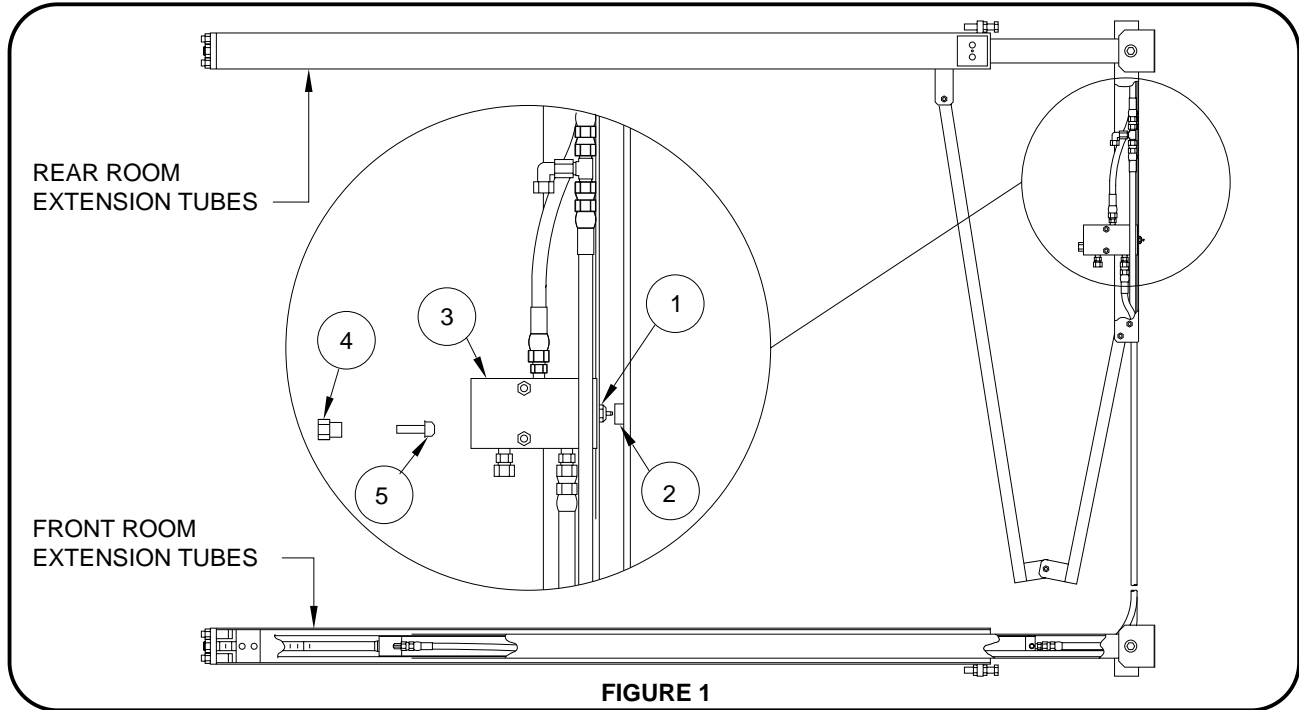

FIGURE 1

ROOM IN EXTENDED POSITION

Refer to page MP35.9490 in the Operator's Manual or the repair manual, and try to manually retract the room, if it is extended. If the manual winch provided will not retract the room, **DO NOT USE ALTERNATE DEVICES SUCH AS A POWER WINCH.** If possible repair the rack sensing valve (3, FIGURE 1) before retracting the room. If repair is not possible, release the pressure on the manual retract winch. Remove the check valve cap (4, FIGURE 1) from the back of the rack sensing valve. Remove the check valve poppet (5, FIGURE 1). Replace the check valve cap. Retract the room using the manual retract winch according to MP35.9490. **DO NOT** use the room extension until the rack sensing valve has been replaced. Leave the manual winch in place and have the room extension repaired.

CAUTION : ROOM EXTENSION SOLENOID VALVE "T" HANDLES MUST BE IN THE OPEN POSITION WHEN THE MANUAL RETRACT WINCH IS CONNECTED. **DO NOT** USE THE ROOM EXTENSION OR LEVELING SYSTEM WHEN THE ROOM EXTENSION HYDRAULIC HOSES ARE DISCONNECTED.

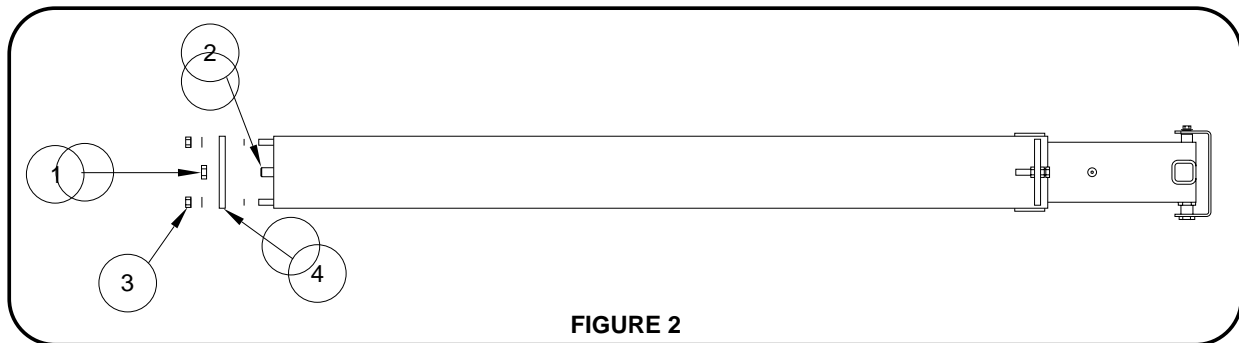

FIGURE 2

ROOM IN RETRACTED POSITION

If one side of the room will not move while extending, repair the rack sensing valve before continuing. Remove the cylinder adjusting locknut (1, FIGURE 2). Turn the cylinder adjusting rod (2, FIGURE 2) clockwise as far as possible. If this is not enough room to work on the valve, remove the cylinder mounting plate nuts (3, FIGURE 2) and the cylinder mounting plate (4, FIGURE 2). The room can then be pulled out far enough to work on the rack sensing valve. Contact HWH Corporation, 1-800-321-3494, for the correct rack sensing valve and cylinder replacement and adjustment instruction sheets.

MANUAL ROOM RETRACT PROCEDURE (WITH SOLENOID VALVES WITH VALVE RELEASE "T" HANDLES)

(USE ONLY WHEN THE ROOM WILL NOT RETRACT WITH THE ROOM CONTROL SWITCH)

OVERVIEW

The room can be retracted manually if a hydraulic or electrical failure prevents the room from being retracted using the ROOM CONTROL SWITCH. For normal retract sequence see the ROOM RETRACT PROCEDURE.

CAUTION: THE MANUAL RETRACT WINCH IS EQUIPPED FOR MANUALLY RETRACTING THE ROOM ONLY. IT IS NOT TO BE USED FOR LIFTING OR ANY OTHER APPLICATION. HIGH FORCES ARE CREATED WHEN USING A WINCH, CREATING POTENTIAL SAFETY HAZARDS. FAILURE TO FOLLOW ALL CAUTIONS AND INSTRUCTIONS MAY CAUSE FAILURE OF THE MANUAL RETRACT WINCH OR CONNECTIONS RESULTING IN DAMAGE OR PERSONAL INJURY. MAINTAIN FIRM GRIP ON THE WINCH HANDLE AT ALL TIMES. NEVER RELEASE THE HANDLE WHEN RATCHET LEVER IS IN THE OFF POSITION AND THE WINCH IS LOADED. THE WINCH HANDLE COULD SPIN VIOLENTLY AND CAUSE PERSONAL INJURY. CHECK THE WINCH AND STRAPS FOR DAMAGE OR WEAR, AND CHECK FOR PROPER RATCHET OPERATION ON EACH USE OF THE WINCH. DO NOT USE IF DAMAGED OR WORN.

1. Retract jacks following the LEVELING SYSTEM RETRACT PROCEDURE.

NOTE : When manually retracting the room, make sure the jacks are retracted before retracting the room.

2. Locate the HYDRAULIC PUMP/MANIFOLD unit.

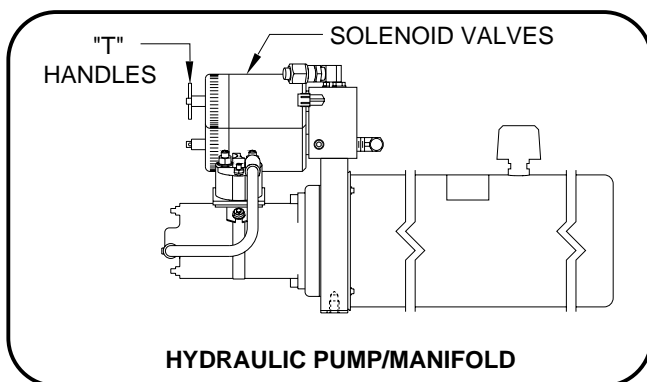

3. Open the SOLENOID VALVES by turning the "T" HANDLES counterclockwise.

NOTE : The "T" HANDLE may turn easily at first but will become more difficult to turn as an internal spring is compressed. Be sure to open both valves completely (about six turns of "T" HANDLE).

NOTE : The room may move slightly as the SOLENOID VALVES are opened and internal pressure is released.

4. Locate the MANUAL RETRACT WINCH and connect it to the room according to the vehicle manufacturer's instructions. To extend the WINCH STRAP firmly grasp WINCH HANDLE, place RATCHET LEVER in its OFF position, and slowly rotate the WINCH HANDLE counterclockwise, keeping a firm grip on the handle. When enough WINCH STRAP is extended, place the RATCHET LEVER in its ON position and slowly rotate the WINCH HANDLE clockwise until the RATCHET LEVER locks.

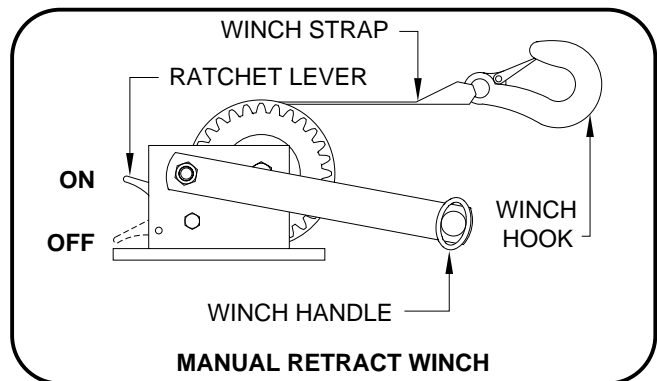

5. Slowly winch the room in by turning the WINCH HANDLE clockwise. The RATCHET LEVER should produce a loud, sharp, clicking noise.

NOTE : Winching the room in quickly will raise pressure in the hydraulic fluid and make winching more difficult.

CAUTION: OPERATE THE MANUAL RETRACT WINCH BY HAND POWER ONLY. IF THE WINCH CANNOT BE CRANKED EASILY WITH ONE HAND IT IS PROBABLY OVERLOADED. IF WINCHING BECOMES TOO DIFFICULT STOP AND CHECK FOR OBSTRUCTIONS OR RESTRICTIONS ON THE ROOM AND ROOM EXTENSION MECHANISM.

6. When the room is fully retracted, engage the room locking devices. Leave the retract winch in place.

CAUTION: THE ROOM EXTENSION SOLENOID VALVE "T" HANDLES MUST BE IN THE OPEN POSITION WHEN THE MANUAL RETRACT WINCH IS ENGAGED.

7. The system should be repaired before using again.

MAINTENANCE

OIL LEVEL

It is important that the four leveling jacks and all HWH room extensions are fully retracted before checking the oil level. To check the oil supply, remove the breather cap from the top of the hydraulic reservoir. The oil level should be approximately one inch below the top of the reservoir when adequately filled.

FLUID: HWH Specialty Hydraulic Oil is recommended. In an emergency Dexron automatic transmission fluid can be used.
NOTE: Dexron automatic transmission fluid contains red dye and can cause staining should a leak occur. **DO NOT USE** brake fluid or hydraulic jack fluid. Use of these can damage seals.

ELECTRICAL SYSTEM

The batteries should be in good condition and fully charged. All electrical connections, especially ground connections, should be clean, tight, free from corrosion and protected

from corrosion. Weak batteries can cause erratic operation. Battery cable terminals, battery posts and connections should be kept clean and protected from corrosion.

UNUSUAL CONDITIONS

If driving conditions are unusually muddy, the jacks may become caked or clogged with mud. This condition may hamper the proper operation of the leveling system. This problem may be prevented or remedied by cleaning off each leveling jack if they become excessively muddy.

Do not move the vehicle while the leveling jacks are still in contact with the ground. Place the system in the store mode and then visually check to see if the leveling jacks have returned to the STORE/TRAVEL position.

In wet or icy weather leveling jacks may become encrusted with ice. This may cause the leveling system to function improperly. To eliminate this problem, periodically check the leveling jacks and break loose any ice which may be causing improper operation.

NOTE: All major components of the system can be replaced with rebuilt parts or can be sent to HWH CORPORATION to be rebuilt, when the system is out of warranty.

LEVEL SENSING UNIT ADJUSTMENT

Level the vehicle by placing a circular bubble level in the center of the freezer floor or location within the vehicle that is to be level. With the vehicle level, adjust the sensing unit until all yellow lights are off. This is done by drawing up the corresponding screw if the sensing unit is mounted below the surface as shown or backing out the corresponding screw if the sensing unit is mounted above the surface. Bump the sensing unit to see that it is settled tight against all three screw heads and still indicates that the unit is level.

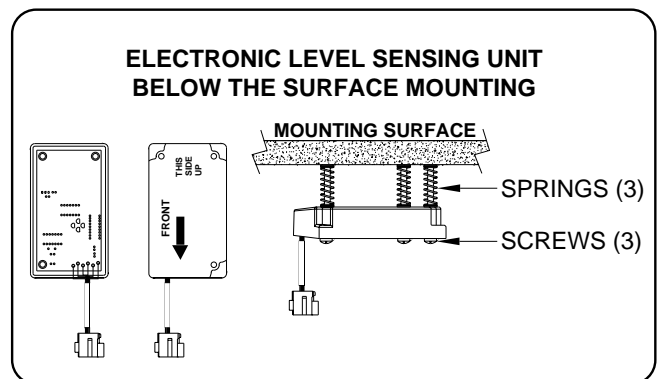
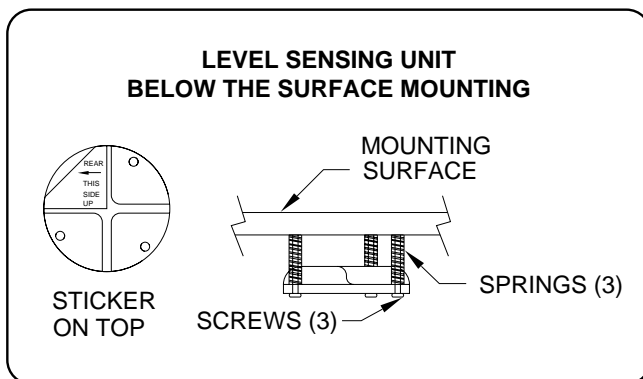

TROUBLE SHOOTING

The following is a list of problems, and possible solutions, which might occur to the leveling and room extension systems.

NOTE : Only qualified technicians should install or repair leveling and room extension systems. A knowledge of hydraulics, welding, and the vehicle's suspension and electrical systems is required. In addition, an understanding of the leveling and room extension systems' hydraulics and electronics is required.

- 1. JACK RETRACTS AFTER COACH IS LEVEL.**
 - A. Hose or jack has external leak.
 - B. Fluid is leaking back to reservoir through the control valve.
- 2. JACKS WILL NOT RETRACT COMPLETELY.**
 - A. Jack clogged with mud or ice.
 - B. Main rod bent or scored.
 - C. Valve plunger is not completely depressed by valve handle.
 - D. Spring weak or broken.
 - E. Hydraulic line pinched.
- 3. IGNITION SWITCH IS ON, BUT NO POWER TO PUMP AND OR LIGHTS.**
 - A. Park brake not set.
 - B. 12 volts from power source not present.
 - C. Faulty PC board.
 - D. Faulty wire or electrical connection.
- 4. PUMP WILL NOT ACTIVATE.**
 - A. Grounding switch on valve not working.
 - B. Pump relay not functioning.
 - C. Pump not grounded.
- 5. HYDRAULIC PUMP ACTIVATES WITHOUT USE OF CONTROL VALVE HANDLES.**
 - A. Grounding switch at valve shorted.
 - B. Pump relay stuck.
 - C. Relay control wire shorted to ground.
- 6. HYDRAULIC PUMP ACTIVATES, BUT THE JACKS WILL NOT EXTEND.**
 - A. STORE LEVERS not in the "OPERATE" POSITION.
 - B. Oil supply is low in reservoir.
 - C. Pump is not developing pressure.
 - D. Broken hydraulic line.
- 7. LEVELING LIGHTS (YELLOW) ARE NOT FUNCTIONING PROPERLY.**
 - A. Yellow lights will not go out when vehicle is level: adjust sensing unit.
 - B. If two or more yellow lights are on replace PC board or check level sensing unit.
- 8. WARNING LIGHTS (RED) ARE NOT FUNCTIONING PROPERLY.**
 - A. Light will not come on: check for broken wire at warning switch on the jack.
 - B. Lights will not go out: bad warning switch or wires are shorted to ground.
 - C. Check PC board.
- 9. AIR WILL NOT DUMP FROM SUSPENSION.**
 - A. Bad touch panel.
 - B. Air dump solenoid is bad.
- 10. SUSPENSION WILL NOT INFLATE.**
 - A. Bad touch panel.
 - B. Air dump solenoid is stuck open.
- 11. PANEL SHUTS OFF WHEN THE ROOM CONTROL SWITCH IS PRESSED.**
 - A. Engine battery is low.
 - B. Faulty wire or electrical connection.
- 12. PUMP RUNS BUT ROOM DOES NOT MOVE.**
 - A. Faulty wire or electrical connection.
 - B. Bad solenoid valve.
- 13. PUMP DOES NOT COME ON WHEN ROOM CONTROL SWITCH IS PRESSED.**
 - A. The panel is off.
 - B. ROOM CONTROL SWITCH is faulty.
 - C. Faulty wire or electrical connection.
- 14. ROOM CREEPS IN AFTER BEING EXTENDED.**
 - A. Retract solenoid valve has an internal leak.
 - B. External fluid leak.
- 15. ROOM CREEPS OUT AFTER CLOSED.**
 - A. EXTEND SOLENOID VALVE has an internal leak.
 - B. FRONT OR REAR CYLINDER on room extension has an internal leak.

HYDRAULIC CONNECTION DIAGRAM BI-AXIS VALVE LEVELING SYSTEM WITH DUAL CYLINDER ROOM EXTENSION SYSTEM W/RACK SENSING VALVE

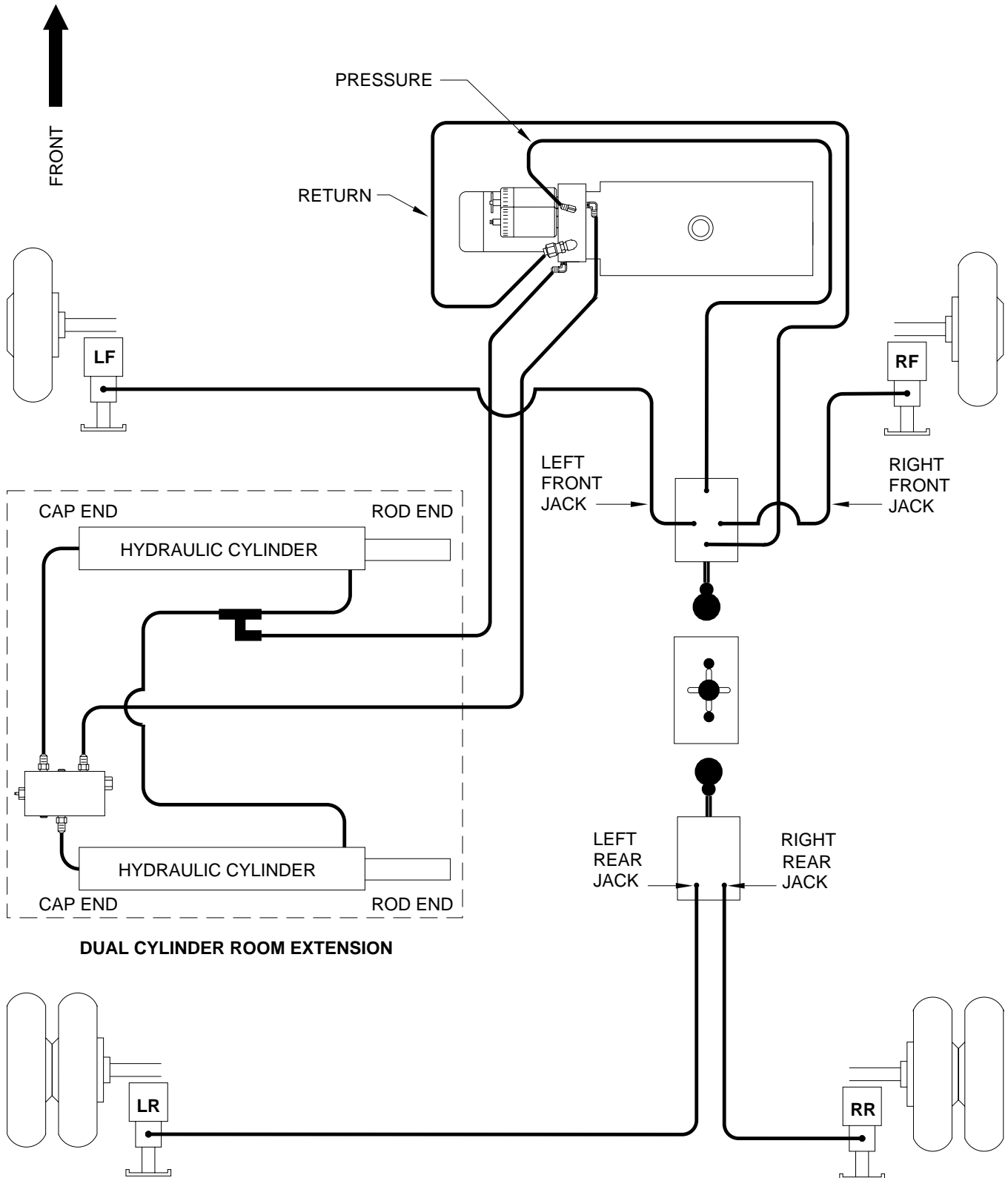

HYDRAULIC SCHEMATIC DIAGRAM DUAL CYLINDER ROOM EXTENSION SYSTEM W/RACK SENSING VALVE

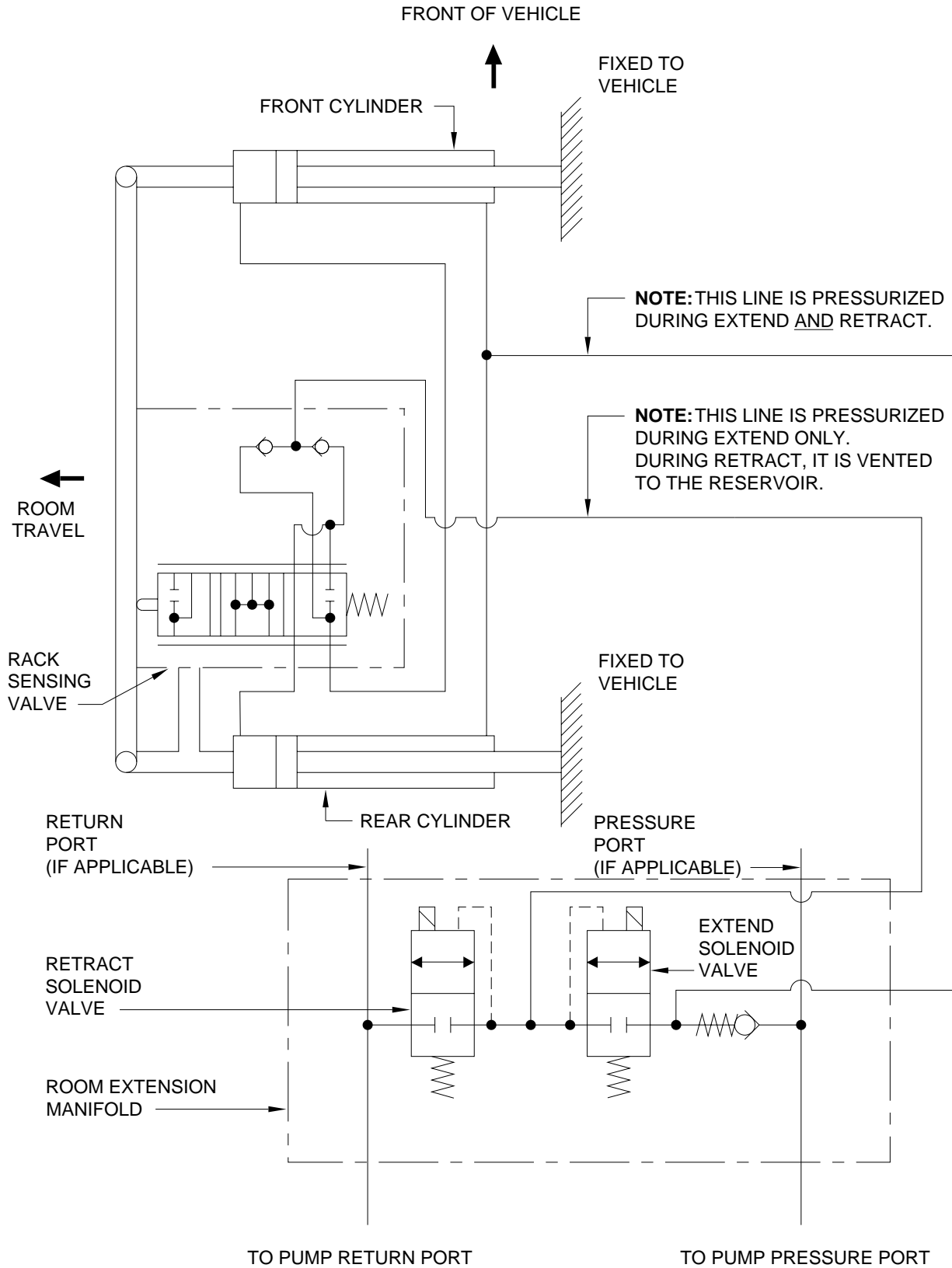

HYDRAULIC SCHEMATIC DIAGRAM
200/210/225 SERIES JOY STICK BI-AXIS LEVELING SYSTEM
WITH STRAIGHT-ACTING JACKS

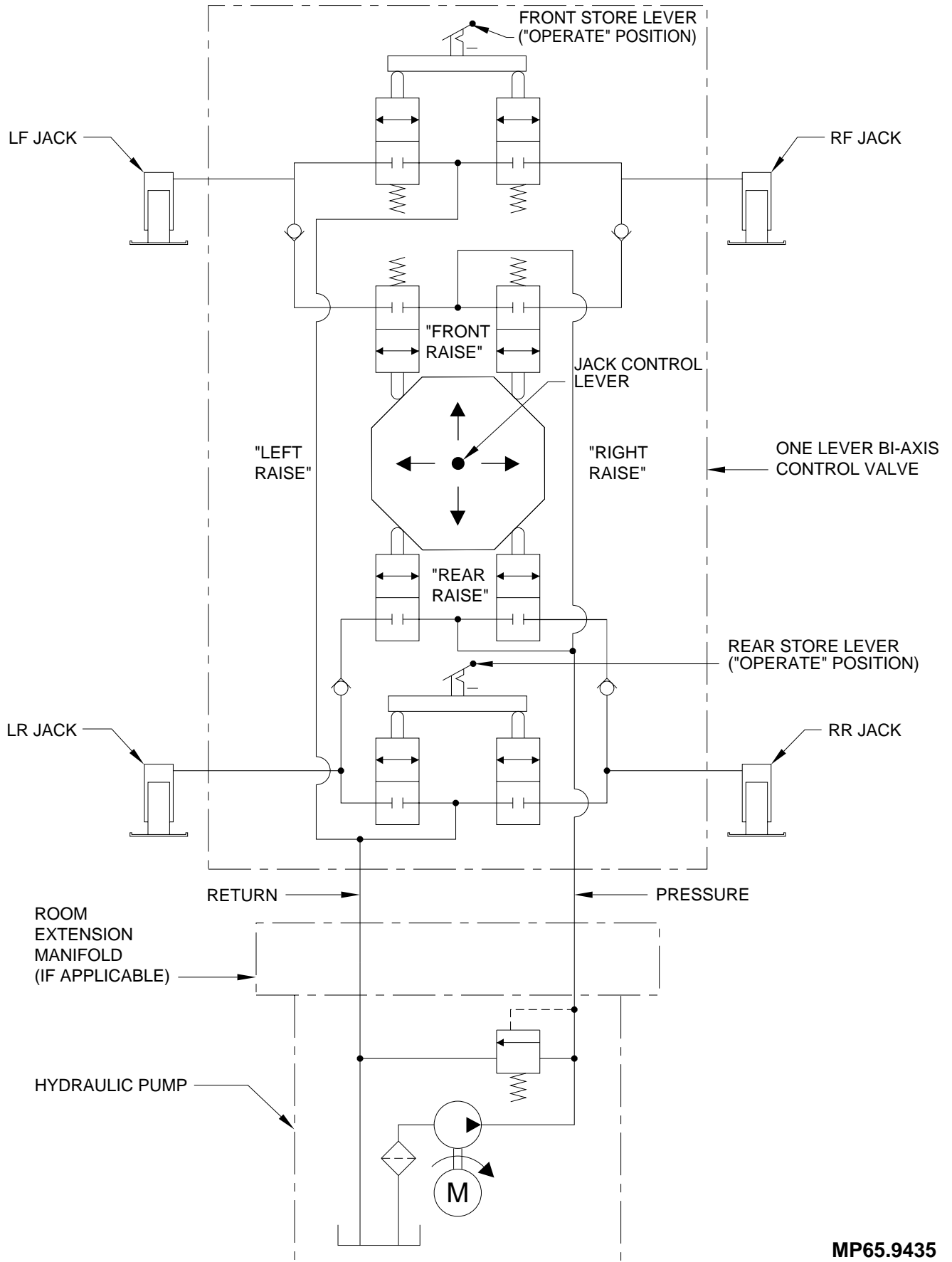

HYDRAULIC FLOW DIAGRAM
DUAL CYLINDER ROOM EXTENSION SYSTEM W/RACK SENSING VALVE
STATIONARY POSITION

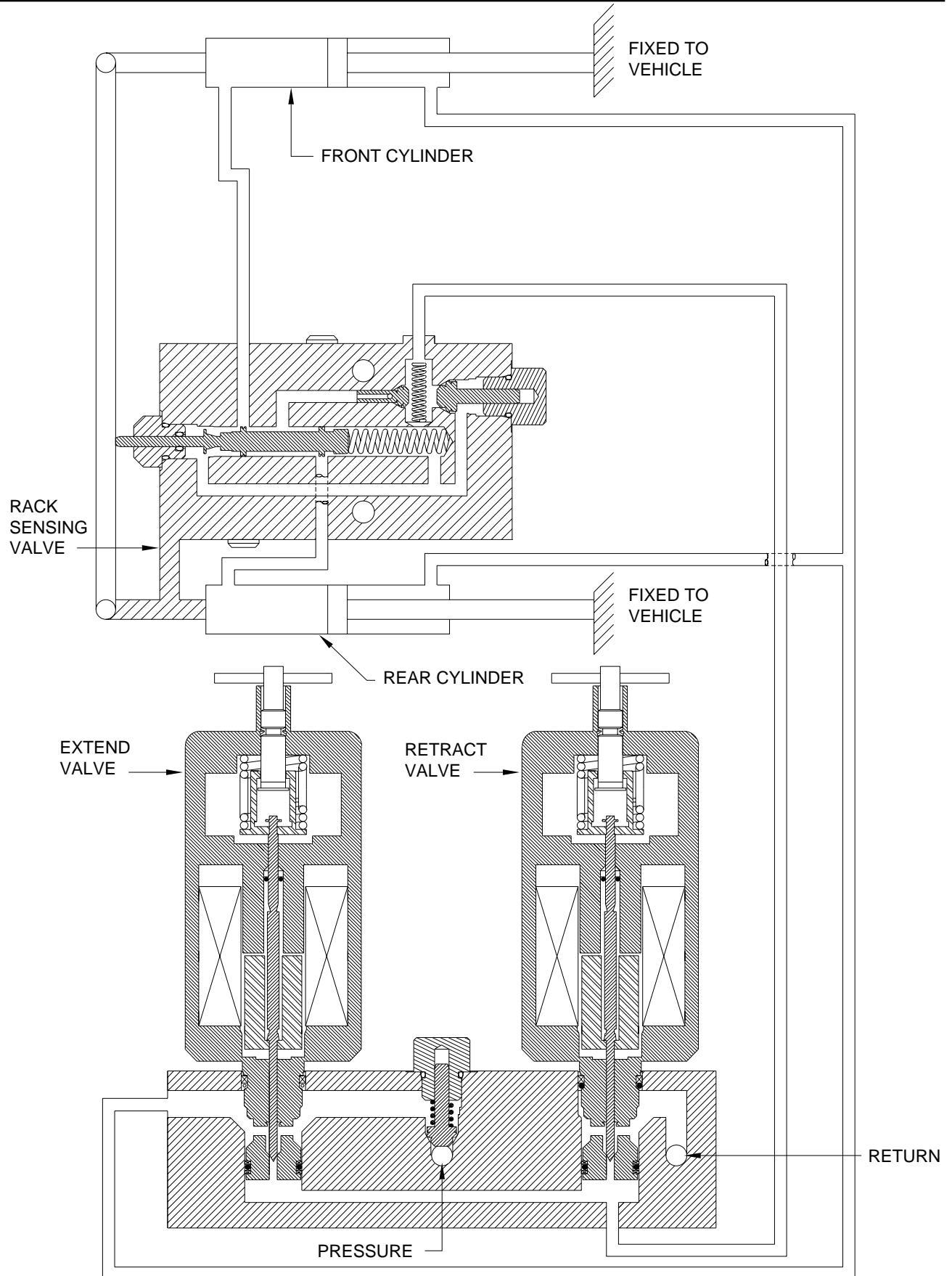

AIR LINE CONNECTION DIAGRAM

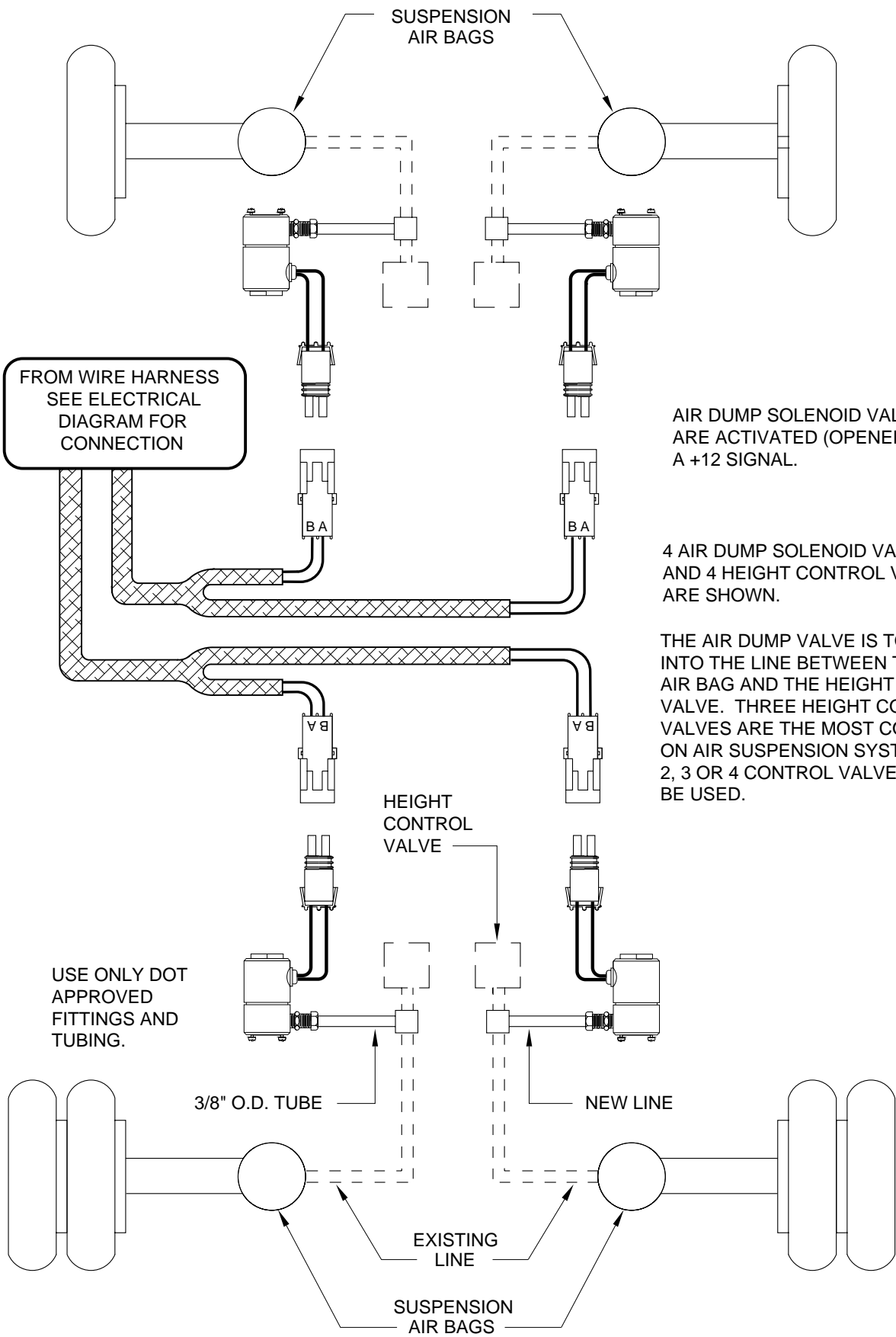

FROM WIRE HARNESS
SEE ELECTRICAL
DIAGRAM FOR
CONNECTION

AIR DUMP SOLENOID VALVES
ARE ACTIVATED (OPENED) BY
A +12 SIGNAL.

4 AIR DUMP SOLENOID VALVES
AND 4 HEIGHT CONTROL VALVES
ARE SHOWN.

THE AIR DUMP VALVE IS TO TEE
INTO THE LINE BETWEEN THE
AIR BAG AND THE HEIGHT CONTROL
VALVE. THREE HEIGHT CONTROL
VALVES ARE THE MOST COMMON
ON AIR SUSPENSION SYSTEMS.
2, 3 OR 4 CONTROL VALVES MAY
BE USED.

USE ONLY DOT
APPROVED
FITTINGS AND
TUBING.

ELECTRICAL CONNECTION DIAGRAM

200 SERIES BI-AXIS VALVE

WITH SUSPENSION AIR DUMP

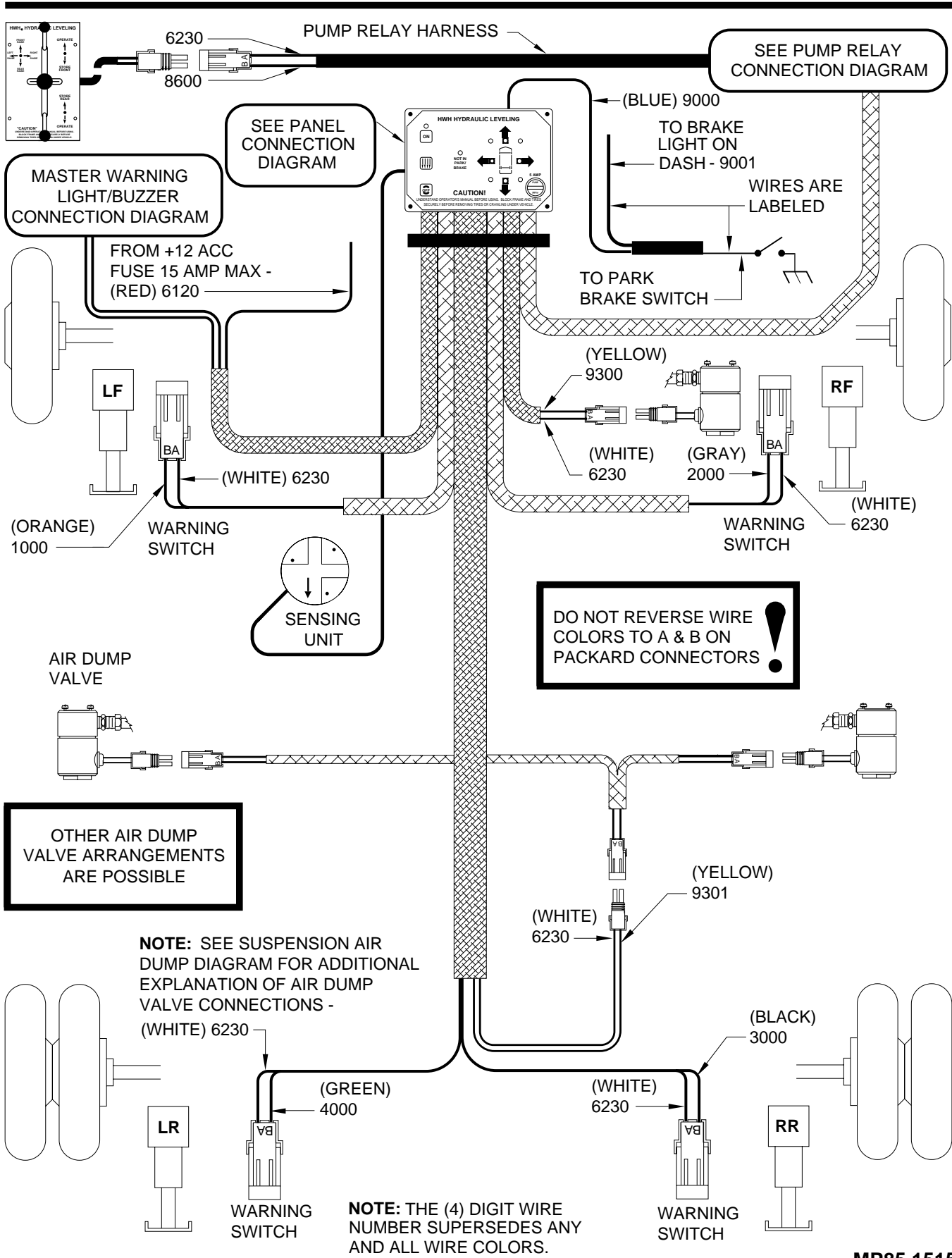

ELECTRICAL CONNECTION DIAGRAM BI-AXIS VALVE WITH ROOM EXTENSION PUMP RELAY AND PANEL WIRING

NOTE: THE (4) DIGIT WIRE NUMBER
SUPERSEDES ANY AND ALL WIRE
COLORS.

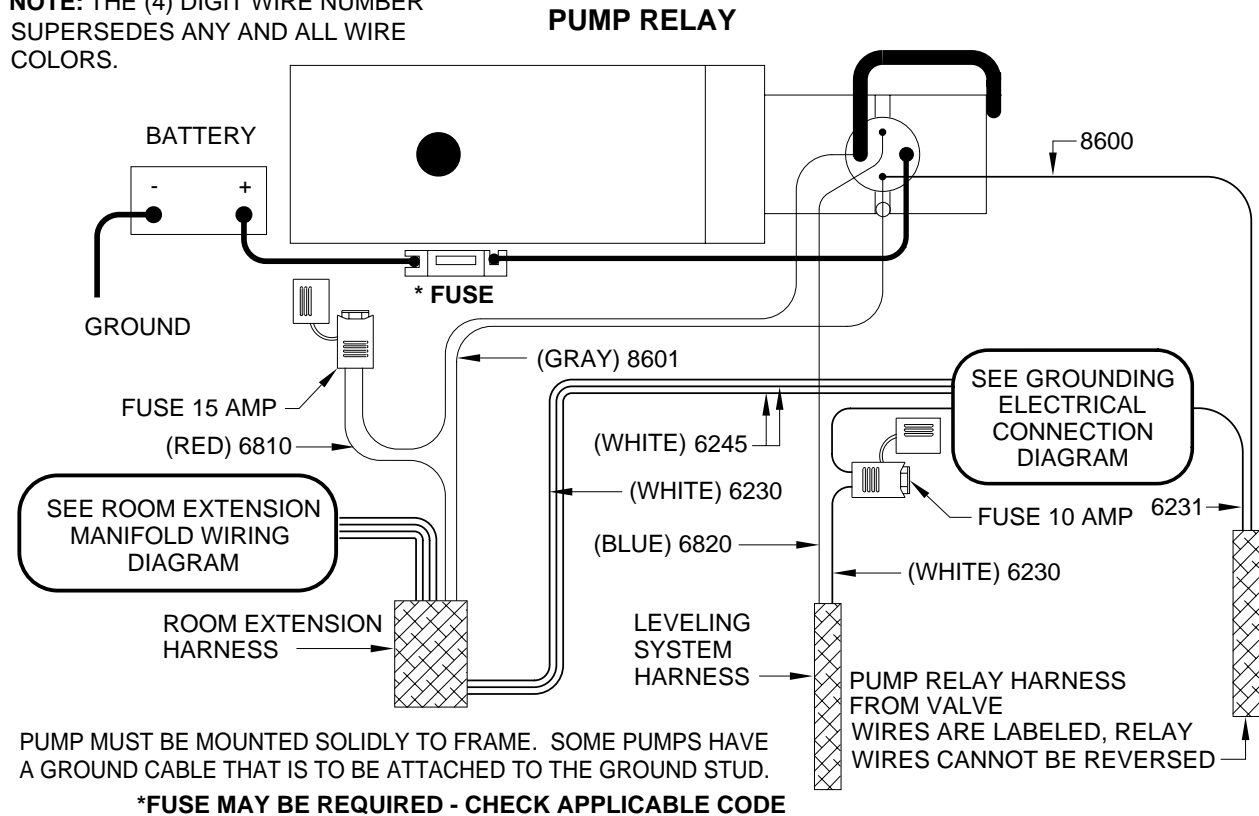

PANEL CONNECTION DIAGRAM

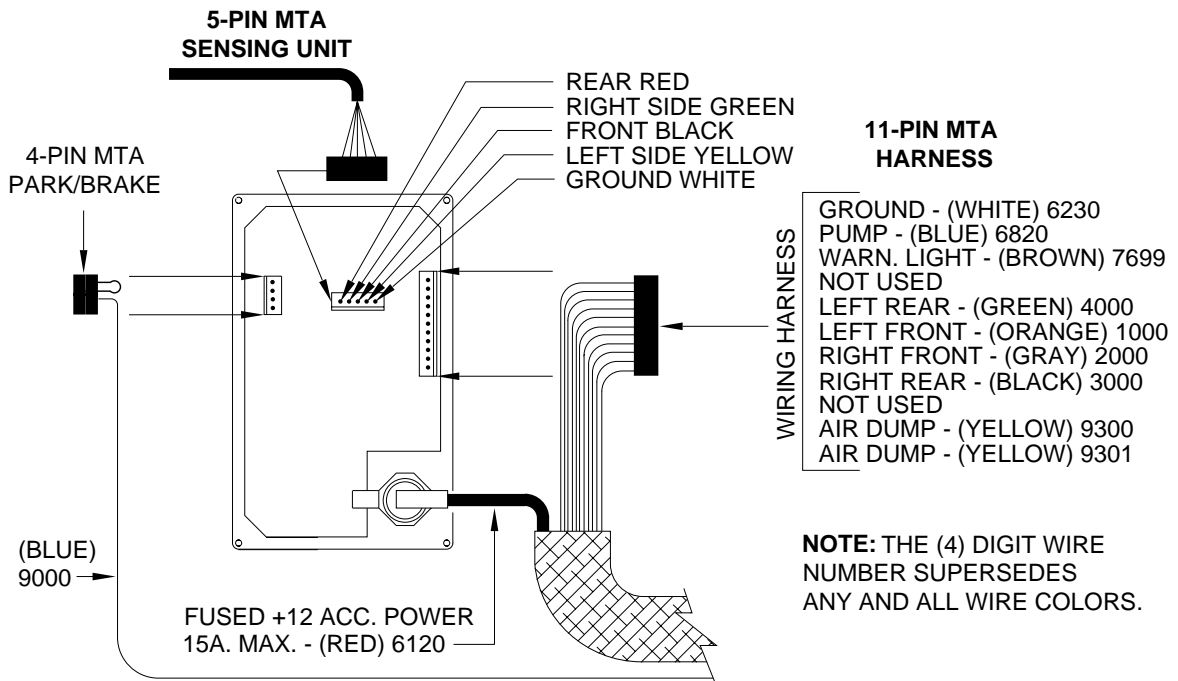

ELECTRICAL CONNECTION DIAGRAM BI-AXIS VALVE WITH ROOM EXTENSION GROUNDING AND MANIFOLD WIRING (LARGE VALVES)

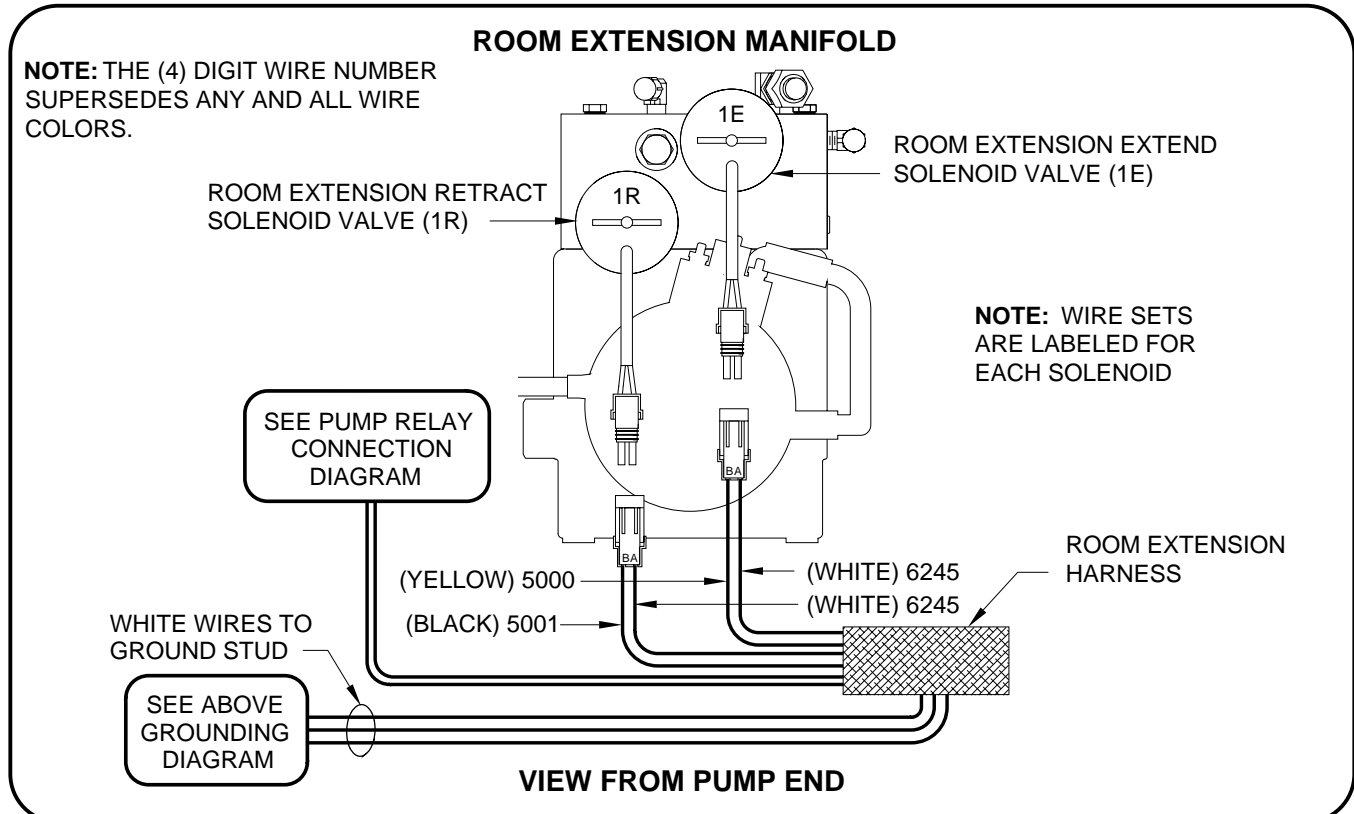
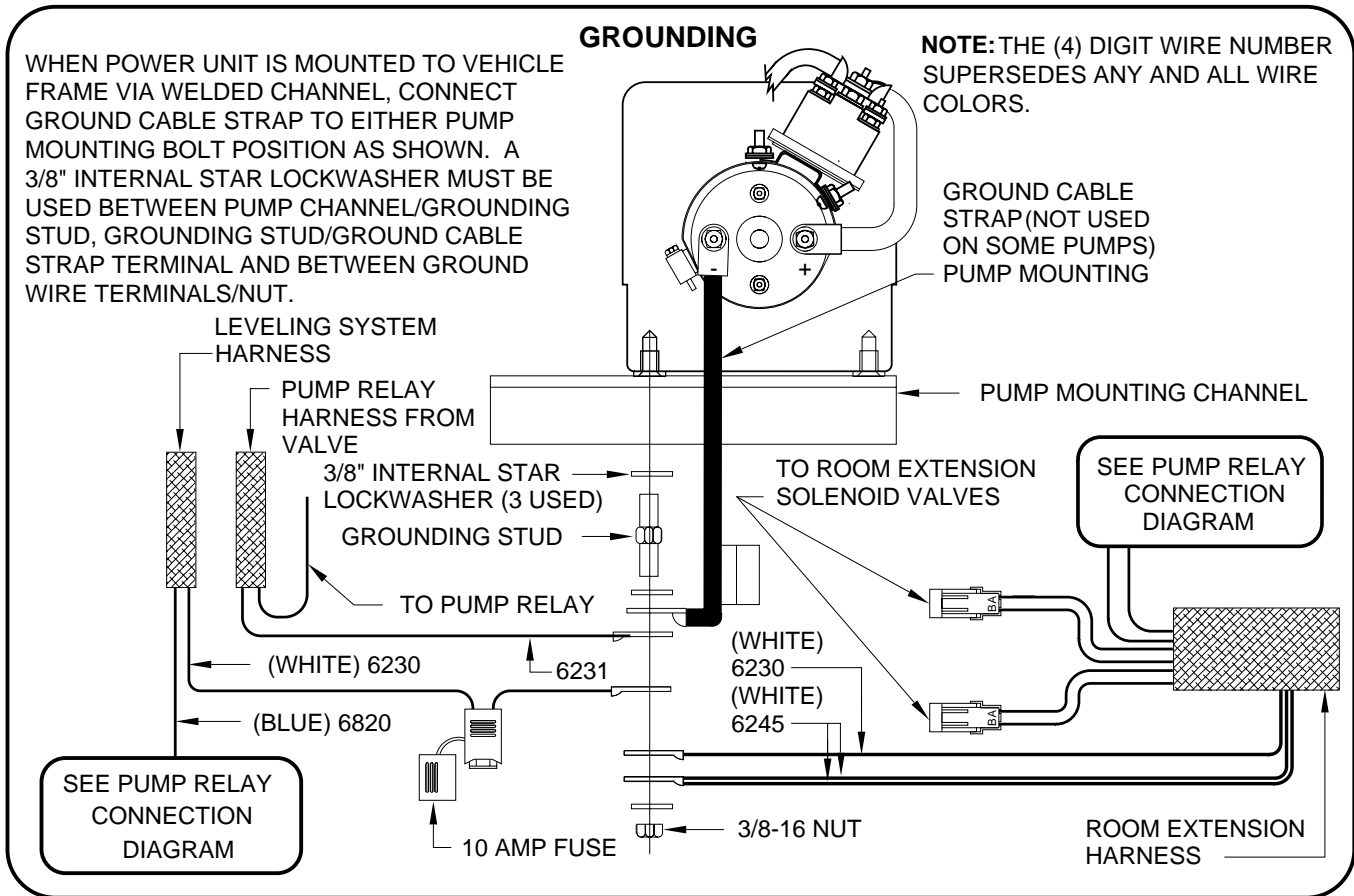

MASTER LIGHT/BUZZER CONNECTION DIAGRAM

JOY STICK-CONTROLLED LEVELING SYSTEMS

NOTE: THE (4) DIGIT WIRE NUMBER
SUPERSEDES ANY AND ALL WIRE
COLORS.

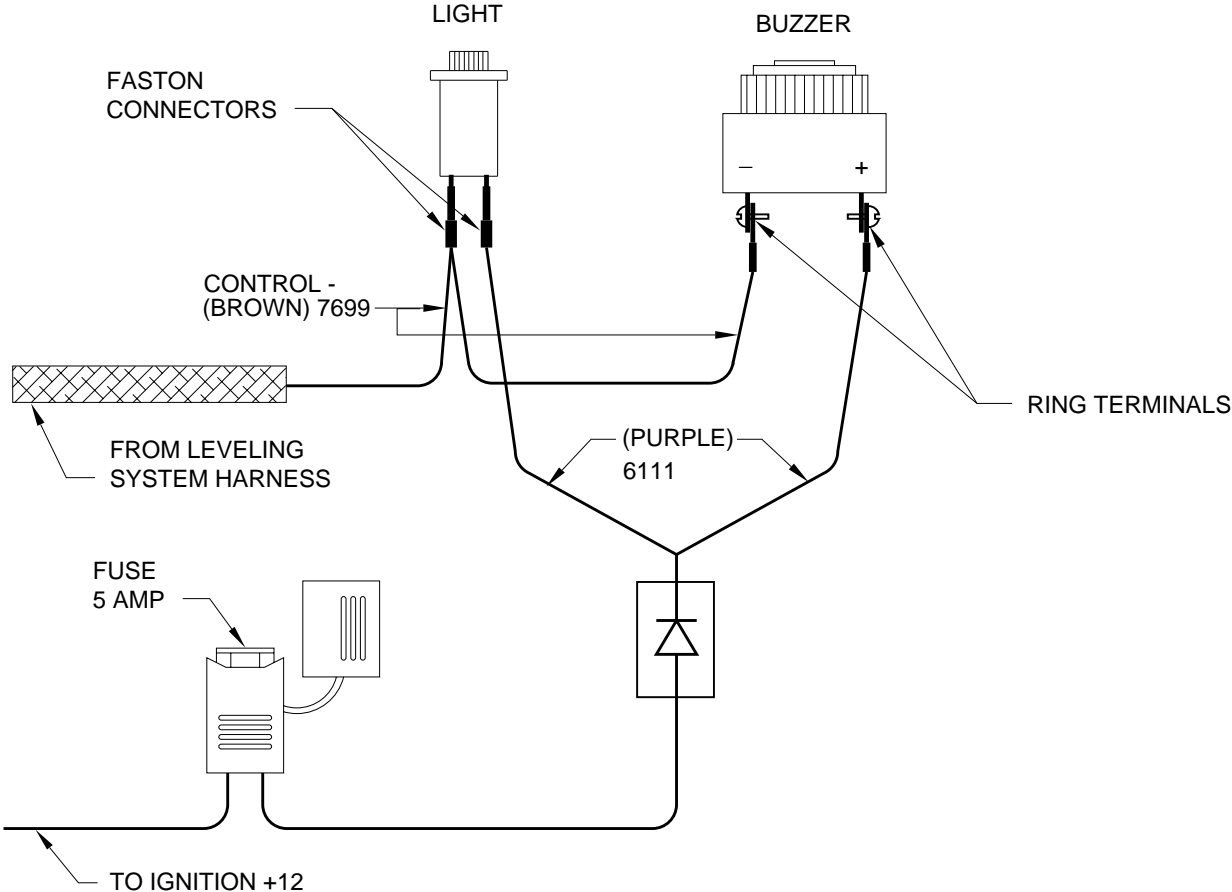

ELECTRICAL CONNECTION DIAGRAM ROOM EXTENSION SYSTEM PANEL CONNECTION

NOTE: FOR VEHICLES WITH MORE THAN ONE ROOM EXTENSION, EACH ROOM EXTENSION WILL HAVE A SEPARATE OPERATOR'S PANEL AND ROOM EXTENSION HARNESS.

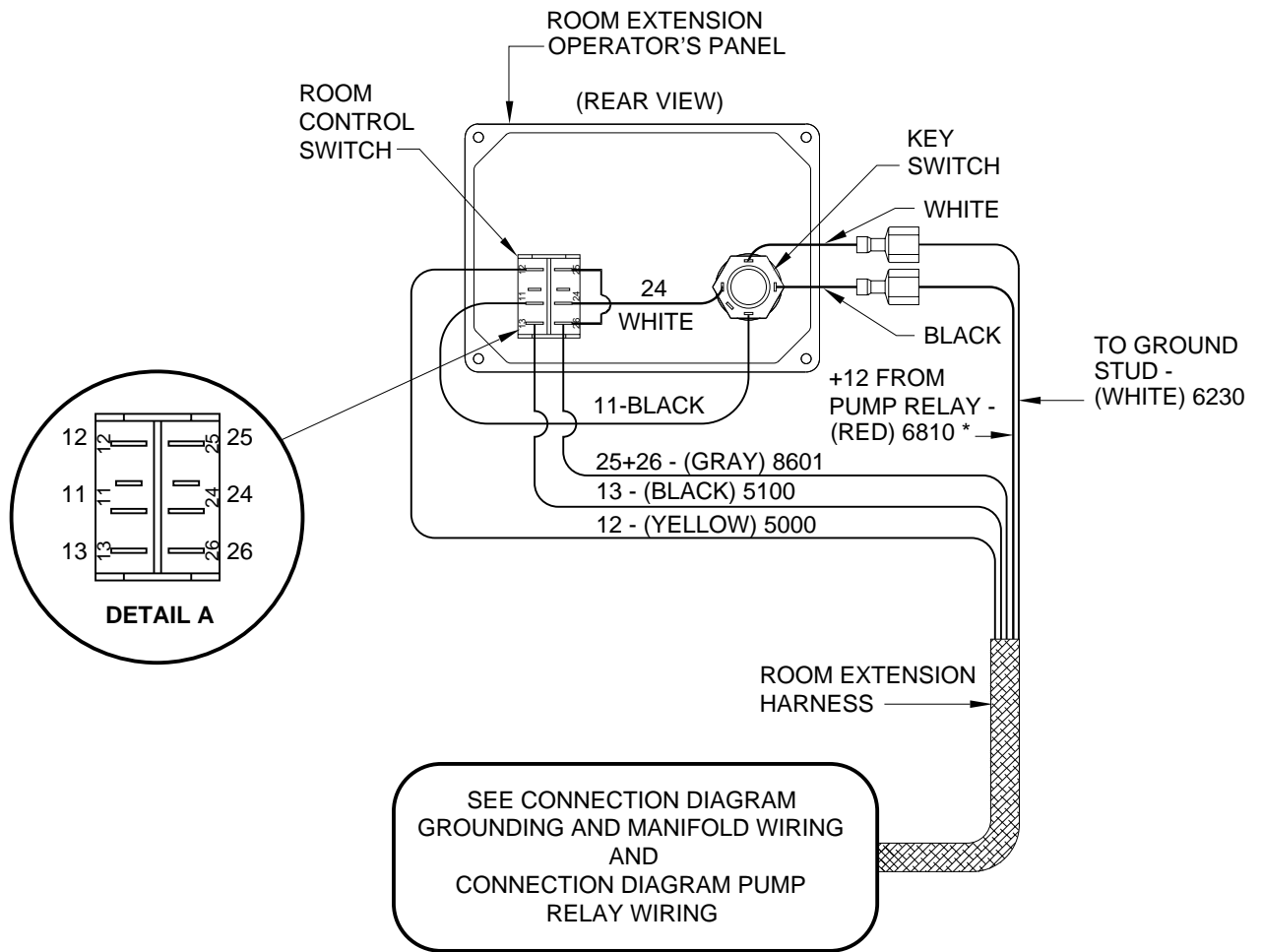

NOTE: THE (4) DIGIT WIRE NUMBER SUPERSEDES ANY AND ALL WIRE COLORS.

* THE (RED) 6810 WIRE SHOULD BE CONNECTED TO THE SWITCHED SIDE OF THE RELAY. SEE THE PUMP RELAY WIRING DIAGRAM.

ELECTRICAL SCHEMATIC

200 SERIES LEVELING SYSTEM LIGHT PANEL

STRAIGHT-ACTING JACKS WITH AIR DUMP FEATURE

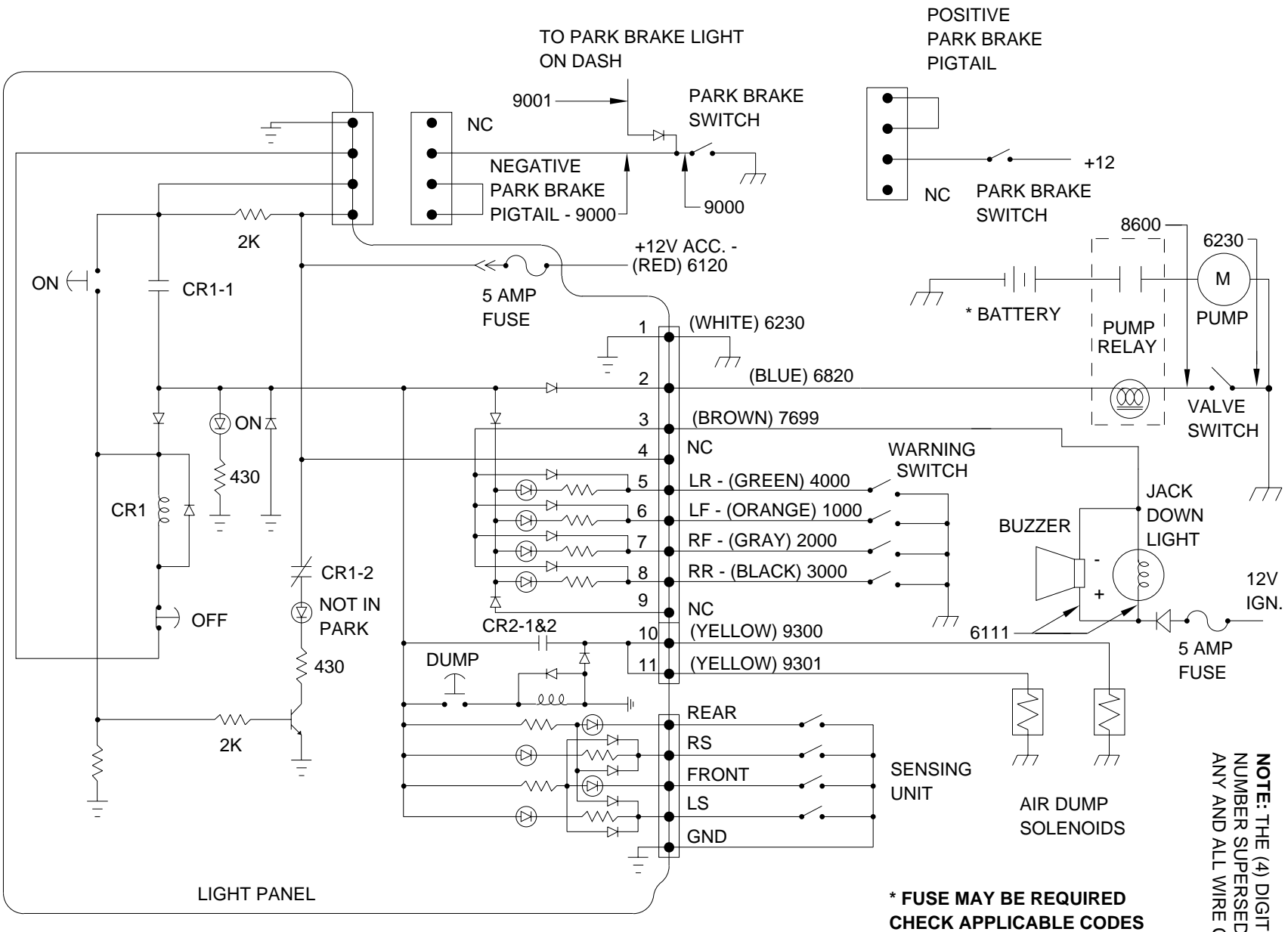

NOTE: THE (4) DIGIT WIRE NUMBER SUPERSEDES ANY AND ALL WIRE COLORS.

* FUSE MAY BE REQUIRED CHECK APPLICABLE CODES