



OPERATOR'S MANUAL

HWH HYDRAULIC SPACEMAKER ROOM EXTENSION SYSTEM

FEATURING:

***DUAL CYLINDER ROOM EXTENSION
(WITH SYNCHRONIZING CYLINDER)
SINGLE CYLINDER ROOM EXTENSION
SINGLE CYLINDER GENERATOR SLIDE***

**HWH CORPORATION
(ON I-80, EXIT 267 SOUTH)
2096 MOSCOW ROAD
MOSCOW, IOWA 52760
(800) 321-3494 / (563) 724-3396
INTERNET: <http://www.hwhcorp.com>**

**ML17127/MP05.9424
16MAR01**

OPERATOR'S MANUAL

CAUTION !

READ THE ENTIRE OPERATOR'S MANUAL BEFORE OPERATING.

KEEP PEOPLE AND OBSTRUCTIONS CLEAR OF ROOMS OR GENERATOR SLIDE WHEN OPERATING. ANY OBJECT OBSTRUCTING MOVEMENT MAY BE CRUSHED CAUSING INJURY OR DEATH AND VEHICLE DAMAGE.

NEVER PLACE HANDS OR OTHER PARTS OF THE BODY NEAR HYDRAULIC LEAKS. OIL MAY PENETRATE SKIN CAUSING INJURY OR DEATH.

WEAR SAFETY GLASSES WHEN INSPECTING OR SERVICING THE SYSTEM TO PROTECT EYES FROM DIRT, METAL CHIPS, OIL LEAKS, ETC. FOLLOW ALL OTHER APPLICABLE SHOP SAFETY PRACTICES.

HOW TO OBTAIN WARRANTY SERVICE

THIS IS NOT TO BE INTERPRETED AS A STATEMENT OF WARRANTY

HWH CORPORATION strives to maintain the highest level of customer satisfaction. Therefore, if you discover a defect or problem, please do the following:

FIRST: Notify the dealership where you purchased the vehicle or had the leveling system installed. Dealership management people are in the best position to resolve the problem quickly. If the dealer has difficulty solving the problem, he should immediately contact the Customer Service Department, at HWH CORPORATION.

SECOND: If your dealer cannot or will not solve the problem, notify the Customer Service Department:
HWH CORPORATION 2096 Moscow Rd. Moscow IA. 52760
(563) 724-3396 OR (800) 321-3494. Give your name and address, coach manufacturer and model year, date the coach was purchased, or the date of system installation,

description of the problem, and where you can be reached during business hours (8:00 a.m. till 5:00 p.m. c.s.t.). HWH CORPORATION personnel will contact you to determine whether or not your claim is valid. If it is, HWH CORPORATION will authorize repair or replacement of the defective part, either by appointment at the factory or by the authorization of an independent service facility, to be determined by HWH CORPORATION. All warranty repairs must be performed by an independent service facility authorized by HWH CORPORATION, or at the HWH CORPORATION factory, unless prior written approval has been obtained from proper HWH CORPORATION personnel.

OPERATING PROCEDURES

ROOM EXTEND PROCEDURE

CAUTION: OPERATING THE ROOM WITH ANY ROOM-LOCKING DEVICES LOCKED OR THE MANUAL-RETRACT WINCH ATTACHED CAN CAUSE PERSONAL INJURY AND VEHICLE DAMAGE. IT IS THE OPERATOR'S RESPONSIBILITY TO ENSURE THAT ALL ROOM-LOCKING DEVICES AND THE MANUAL RETRACT WINCH ARE DISENGAGED BEFORE OPERATING THE ROOM.

IMPORTANT: Do not operate the room extension unless the vehicle is at the proper ride height and the leveling jacks are retracted. If the vehicle is equipped with HWH air leveling, the vehicle should be level before operating the room.

1. Unlock all room-locking devices.

NOTE: If the MANUAL RETRACT WINCH is attached to the room remove it before extending the room.

CAUTION: KEEP PEOPLE AND OBSTRUCTIONS CLEAR OF ROOM WHEN OPERATING.

NOTE: Make sure there is adequate clearance to fully extend the room.

2. Apply the parking brake, the ignition switch must be OFF.

NOTE: The room will not operate if the parking brake is not set, and the ignition is in the "ON" or "ACC" Position.

3. The bay doors under the room extension must be closed.

4. To extend the room, press and hold the ROOM CONTROL SWITCH in the "EXTEND" position until the room is fully extended.

NOTE: Hold the switch to "EXTEND" three or four seconds after the room is fully extended. This assures proper pressurization of the cylinders. **During normal operation of the room, do not reverse direction of the room until the room is fully extended. If necessary, the direction of the room may be reversed, but watch for binding of the room. If the direction of the room has been reversed, DO NOT re-extend the room until the room has been fully retracted.**

IMPORTANT: Do not hold the ROOM CONTROL SWITCH in the "EXTEND" position for more than ten seconds after the room is fully extended or stops moving. **If either side of the room stops moving, release the room control switch immediately. DO NOT force the room. DO NOT reverse direction of the room, contact HWH Customer Service for assistance 1-800-321-3494.**

NOTE: Releasing the ROOM CONTROL SWITCH will halt the operation of the room.

ROOM RETRACT PROCEDURE

CAUTION: KEEP PEOPLE AND OBSTRUCTIONS CLEAR OF ROOM WHEN OPERATING.

IMPORTANT: Do not operate the room extension unless the vehicle is at the proper ride height and the leveling jacks are retracted. If the vehicle is equipped with HWH air leveling, the vehicle should be level before operating the room.

1. Make sure the parking brake is applied. The ignition switch must be OFF.

NOTE: The room will not operate if the parking brake is not set, and the ignition is in the "ON" or "ACC" Position.

2. The bay doors under the room extension must be closed.

3. To retract the room press and hold the ROOM CONTROL SWITCH in the "RETRACT" position until the room is fully retracted.

NOTE: Hold the switch to "RETRACT" three or four seconds after the room is fully retracted. This assures proper pressurization of the cylinders. **During normal operation of the room, do not reverse direction of the room until the room is fully retracted. If necessary, the direction of the**

room may be reversed, but watch for binding of the room. If the direction of the room has been reversed, DO NOT retract the room until the room has been fully extended.

IMPORTANT: Do not hold the ROOM CONTROL SWITCH in the "RETRACT" position for more than ten seconds after the room is fully retracted or stops moving. **If either side of the room stops moving, release the room control switch immediately. DO NOT force the room. DO NOT reverse direction of the room, contact HWH Customer Service for assistance 1-800-321-3494.**

NOTE: Releasing the ROOM CONTROL SWITCH will halt the operation of the room.

4. Engage all room-locking devices.

5. If the room will not retract see the MANUAL ROOM RETRACT PROCEDURE.

IMPORTANT: Room-locking devices should be locked while traveling.

OPERATING PROCEDURES

GENERATOR SLIDE EXTEND PROCEDURE

CAUTION: KEEP PEOPLE AND OBSTRUCTIONS CLEAR OF SLIDE WHEN OPERATING.

NOTE: Make sure there is adequate clearance to fully extend the slide.

1. THE PARK BRAKE MUST BE SET FOR THE SLIDE TO OPERATE.

2. To extend the slide, press and hold the GENERATOR SLIDE CONTROL SWITCH in the "EXTEND" position. When the slide is fully extended, release the GENERATOR SLIDE CONTROL SWITCH.

NOTE: There is a GENERATOR SLIDE CONTROL SWITCH on the dash and also in the front electrical bay.

IMPORTANT: Do not hold the GENERATOR SLIDE CONTROL SWITCH in the "EXTEND" position for more than ten seconds after the slide is fully extended or stops moving. **DO NOT FORCE THE SLIDE.**

NOTE: Releasing the GENERATOR SLIDE CONTROL SWITCH will halt the operation of the slide.

GENERATOR SLIDE RETRACT PROCEDURE

1. THE PARK BRAKE MUST BE SET FOR THE SLIDE TO OPERATE.

2. To retract the slide, press and hold the GENERATOR SLIDE CONTROL SWITCH in the "RETRACT" position. When the slide is fully retracted, release the GENERATOR SLIDE CONTROL SWITCH.

NOTE: There is a GENERATOR SLIDE CONTROL SWITCH on the dash and also in the front electrical bay.

IMPORTANT: Do not hold the GENERATOR SLIDE CONTROL SWITCH in the "RETRACT" position for more than ten seconds after the slide is fully retracted or stops moving. **DO NOT FORCE THE SLIDE.**

NOTE: Releasing the GENERATOR SLIDE CONTROL SWITCH will halt the operation of the slide.

3. If the slide will not retract see the MANUAL SLIDE RETRACT PROCEDURE.

MANUAL ROOM RETRACT PROCEDURE (WITH SOLENOID VALVES WITH VALVE RELEASE "T" HANDLES)

(USE ONLY WHEN THE ROOM WILL NOT RETRACT WITH THE ROOM CONTROL SWITCH)

OVERVIEW

The room can be retracted manually if a hydraulic or electrical failure prevents the room from being retracted using the ROOM CONTROL SWITCH. For normal retract sequence see the ROOM RETRACT PROCEDURE.

CAUTION: THE MANUAL RETRACT WINCH IS EQUIPPED FOR MANUALLY RETRACTING THE ROOM ONLY. IT IS NOT TO BE USED FOR LIFTING OR ANY OTHER APPLICATION. HIGH FORCES ARE CREATED WHEN USING A WINCH, CREATING POTENTIAL SAFETY HAZARDS. FAILURE TO FOLLOW ALL CAUTIONS AND INSTRUCTIONS MAY CAUSE FAILURE OF THE MANUAL RETRACT WINCH OR CONNECTIONS RESULTING IN DAMAGE OR PERSONAL INJURY. MAINTAIN FIRM GRIP ON THE WINCH HANDLE AT ALL TIMES. NEVER RELEASE THE HANDLE WHEN RATCHET LEVER IS IN THE OFF POSITION AND THE WINCH IS LOADED. THE WINCH HANDLE COULD SPIN VIOLENTLY AND CAUSE PERSONAL INJURY. CHECK THE WINCH AND STRAPS FOR DAMAGE OR WEAR, AND CHECK FOR PROPER RATCHET OPERATION ON EACH USE OF THE WINCH. DO NOT USE IF DAMAGED OR WORN.

1. Retract jacks following the LEVELING SYSTEM RETRACT PROCEDURE.

NOTE : When manually retracting the room, make sure the jacks are retracted before retracting the room.

2. Locate the HYDRAULIC PUMP/MANIFOLD unit.

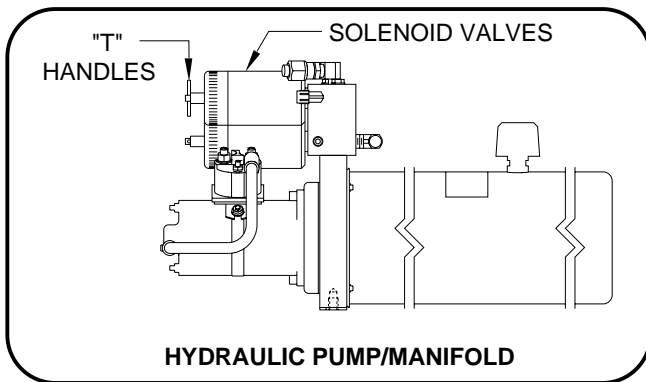

3. Open the SOLENOID VALVES by turning the "T" HANDLES counterclockwise.

NOTE : The "T" HANDLE may turn easily at first but will become more difficult to turn as an internal spring is compressed. Be sure to open both valves completely (about six turns of "T" HANDLE).

NOTE : The room may move slightly as the SOLENOID VALVES are opened and internal pressure is released.

4. Locate the MANUAL RETRACT WINCH and connect it to the room according to the vehicle manufacturer's instructions. To extend the WINCH STRAP firmly grasp WINCH HANDLE, place RATCHET LEVER in its OFF position, and slowly rotate the WINCH HANDLE counterclockwise, keeping a firm grip on the handle. When enough WINCH STRAP is extended, place the RATCHET LEVER in its ON position and slowly rotate the WINCH HANDLE clockwise until the RATCHET LEVER locks.

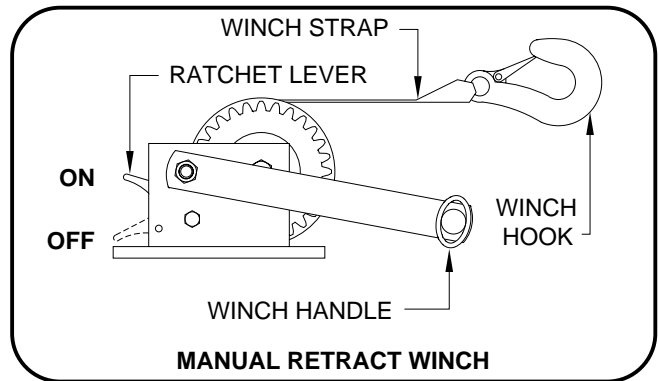

5. Slowly winch the room in by turning the WINCH HANDLE clockwise. The RATCHET LEVER should produce a loud, sharp, clicking noise.

NOTE : Winching the room in quickly will raise pressure in the hydraulic fluid and make winching more difficult.

CAUTION: OPERATE THE MANUAL RETRACT WINCH BY HAND POWER ONLY. IF THE WINCH CANNOT BE CRANKED EASILY WITH ONE HAND IT IS PROBABLY OVERLOADED. IF WINCHING BECOMES TOO DIFFICULT STOP AND CHECK FOR OBSTRUCTIONS OR RESTRICTIONS ON THE ROOM AND ROOM EXTENSION MECHANISM.

6. When the room is fully retracted, engage the room locking devices. Leave the retract winch in place.

CAUTION: THE ROOM EXTENSION SOLENOID VALVE "T" HANDLES MUST BE IN THE OPEN POSITION WHEN THE MANUAL RETRACT WINCH IS ENGAGED.

7. The system should be repaired before using again.

MAINTENANCE

OIL LEVEL

It is important that all rooms and the generator slide are fully retracted before checking the hydraulic oil level. To check the oil supply, remove the breather cap from the top of the hydraulic oil reservoir. The oil level should be approximately one inch below the top of the reservoir when adequately filled.

FLUID: HWH Specialty Hydraulic Oil is recommended. In an emergency Dexron automatic transmission fluid can be used.

NOTE: Dexron automatic transmission fluid contains red dye and can cause staining should a leak occur. **DO NOT USE** brake fluid or hydraulic jack fluid. Use of these can damage seals.

TROUBLE SHOOTING ROOM EXTENSION

The following is a list of problems, and possible solutions, which might occur to the room extension systems.

NOTE: Only qualified technicians should install or repair room systems. A knowledge of hydraulic, welding, the vehicles suspension and electrical systems is required. In addition, an understanding of the room extension system's hydraulics and electronics is required.

1. HYDRAULIC PUMP WILL NOT ACTIVATE WHEN ROOM CONTROL SWITCH IS PRESSED.

- A. The PARK BRAKE is not set.
- B. Bay door is open (ROOMS ONLY).
- C. FUSE is blown.
- D. PUMP RELAY and/or HYDRAULIC PUMP are not properly grounded.
- E. 12 VOLT power to pump relay not present.
- F. Fault wire, electrical connection ROOM CONTROL SWITCH, BAY DOOR SWITCH (ROOM ONLY).

2. HYDRAULIC PUMP ACTIVATES, BUT ROOM WILL NOT EXTEND.

- A. EXTEND SOLENOID VALVE is not properly grounded.
- B. Reservoir oil supply is low.
- C. Hydraulic line is pinched or broken.
- D. Faulty wire, electrical connection, ROOM CONTROL SWITCH , EXTEND SOLENOID VALVE, HYDRAULIC PUMP, or HYDRAULIC CYLINDER.

3. HYDRAULIC PUMP ACTIVATES, BUT ROOM WILL NOT RETRACT.

- A. RETRACT SOLENOID VALVE IS NOT properly grounded.
- B. Reservoir oil supply is low.
- C. Hydraulic line is pinched or broken.
- D. Faulty wire, electrical connection, ROOM CONTROL SWITCH , RETRACT SOLENOID VALVE, HYDRAULIC PUMP, or HYDRAULIC CYLINDER.

4. ROOM CREEPS OUT AFTER CLOSING.

- A. "T" HANDLE on EXTEND SOLENOID VALVE is not closed completely.
- B. EXTEND SOLENOID VALVE has an internal leak.
- C. HYDRAULIC CYLINDER has an internal leak.
- D. The MANIFOLD CHECK VALVE is leaking.

5. ROOM CREEPS IN AFTER BEING EXTENDED.

- A. "T" HANDLE on RETRACT SOLENOID VALVE is not closed completely.
- B. RETRACT SOLENOID VALVE has an internal leak.

HYDRAULIC LINE CONNECTION DIAGRAM

DUAL CYLINDER ROOM EXTENSION W/SYNCHRONIZING CYLINDER

SINGLE CYLINDER ROOM EXTENSION

SINGLE CYLINDER GENERATOR SLIDE

IMPORTANT: THE 3/16" HIGH PRESSURE HOSES BETWEEN THE STEEL TUBES (ROD END) OF THE HYDRAULIC CYLINDERS AND THE SYNCHRONIZING CYLINDER MUST BE THE SAME LENGTH AND DIAMETER.

LINE TO ROD END OF CYLINDER (THIS LINE WILL ALWAYS HAVE PRESSURE ON IT.) (SINGLE OR DUAL CYLINDER)

NOTE: SOME SYSTEMS HAVE 1/8" HIGH PRESSURE HOSE.

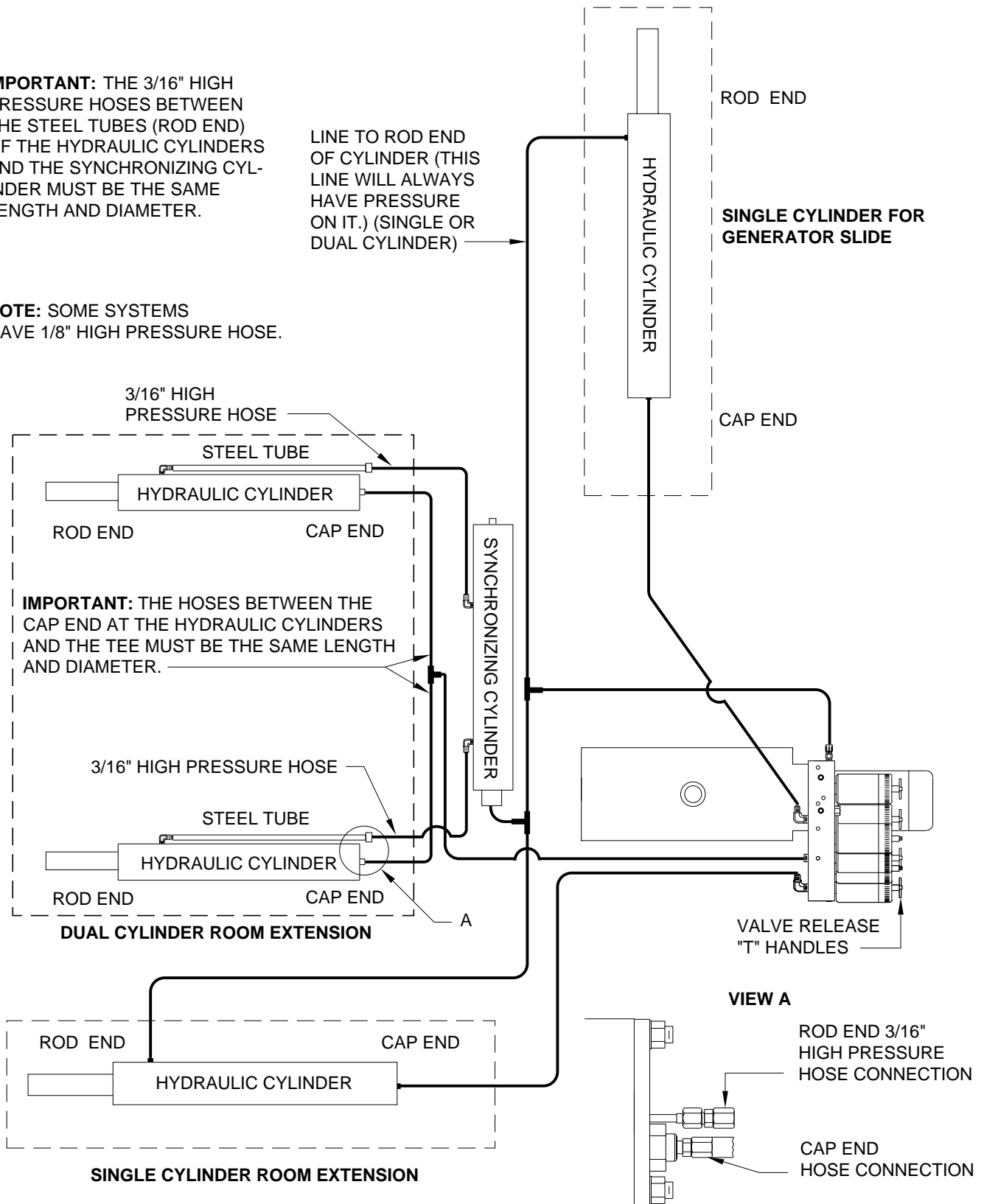

IMPORTANT: THE HOSES BETWEEN THE CAP END AT THE HYDRAULIC CYLINDERS AND THE TEE MUST BE THE SAME LENGTH AND DIAMETER.

DUAL CYLINDER ROOM EXTENSION

SINGLE CYLINDER ROOM EXTENSION

VALVE RELEASE "T" HANDLES

VIEW A

ROD END 3/16" HIGH PRESSURE HOSE CONNECTION

CAP END HOSE CONNECTION

HOSE CONNECTIONS FOR DUAL CYLINDER ROOM EXTENSION WITH SYNCHRONIZING CYLINDER.

HYDRAULIC FLOW DIAGRAM VERTICAL ARM OR DUAL CYLINDER ROOM EXTENSION WITH SYNCHRONIZING CYLINDER EXTEND POSITION

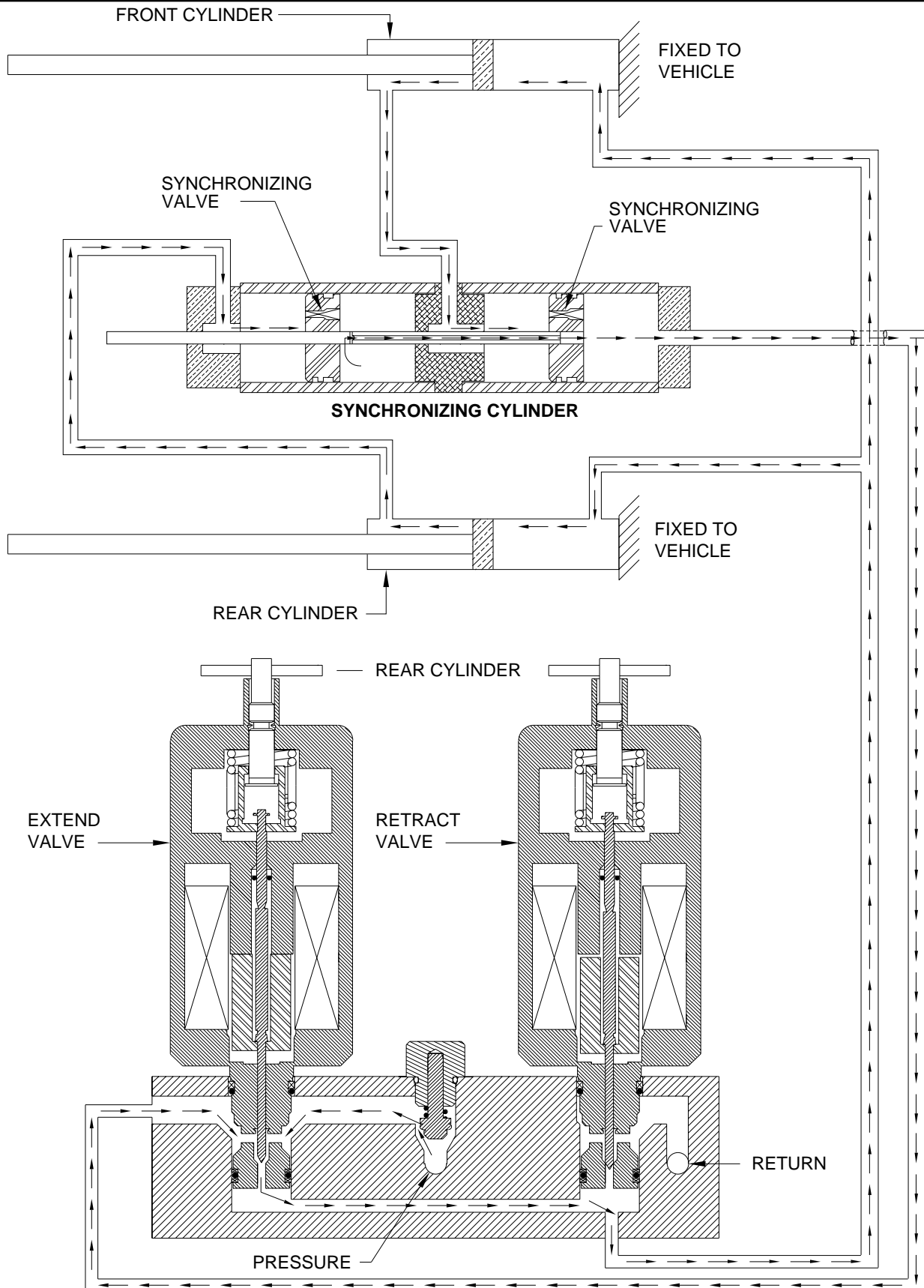

**HYDRAULIC FLOW DIAGRAM
SINGLE CYLINDER ROOM EXTENSION
STATIONARY POSITION**

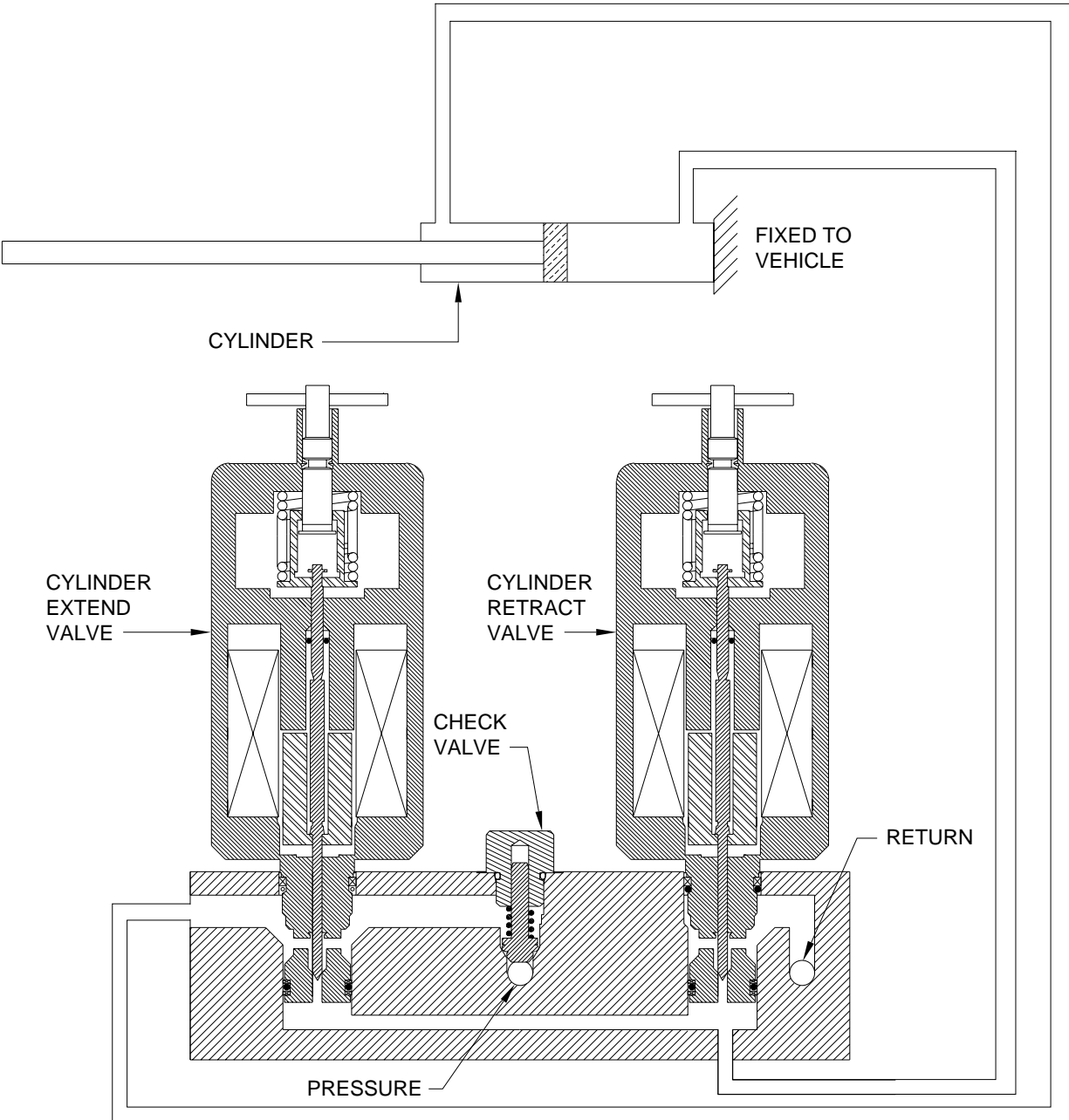

ELECTRICAL CONNECTION DIAGRAM TWO ROOM EXTENSIONS ONE GENERATOR SLIDE

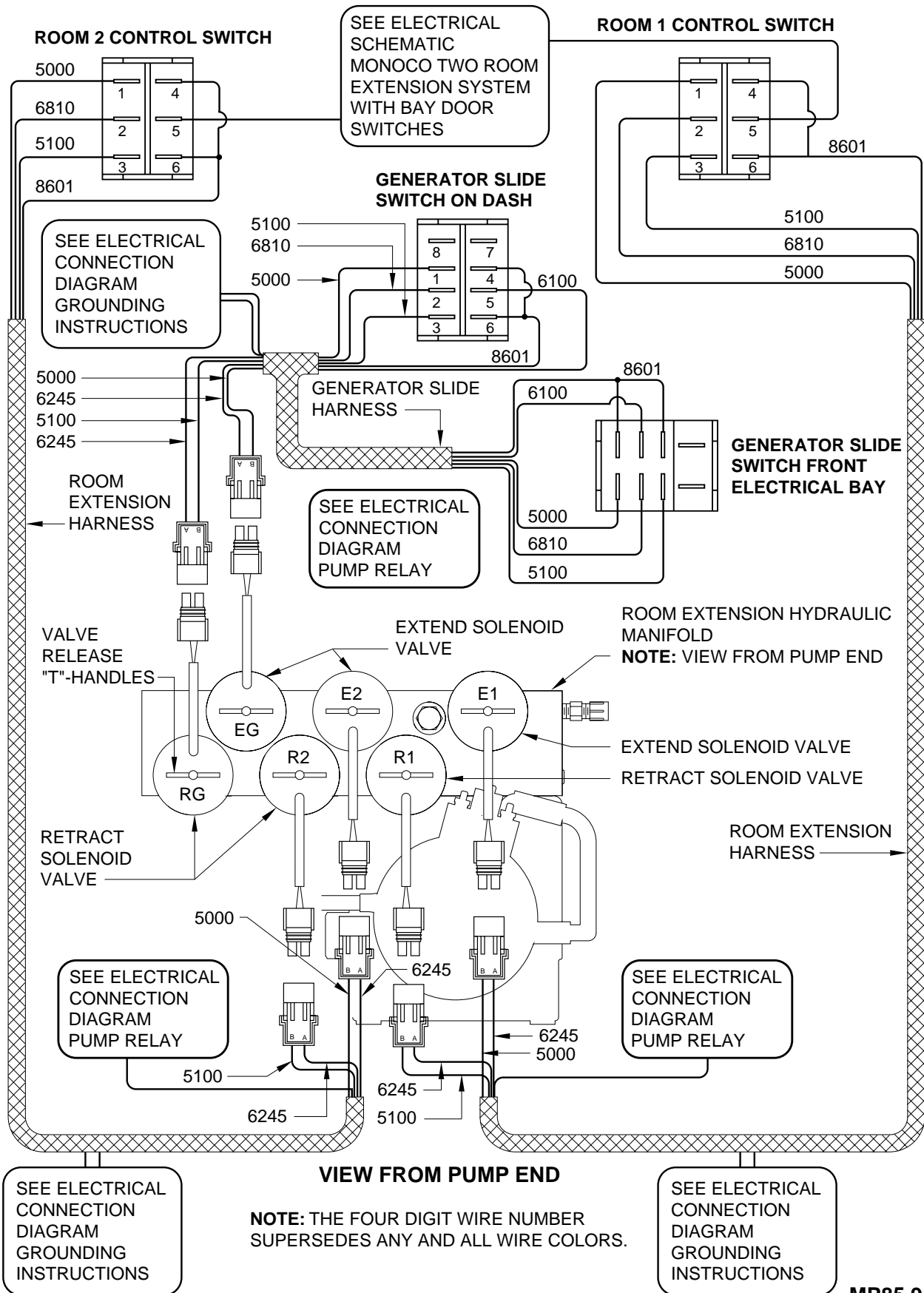

ELECTRICAL CONNECTION DIAGRAM PUMP RELAY

*** FUSE MAY BE REQUIRED - CHECK APPLICABLE CODE**

NOTE: THE (4) DIGIT WIRE NUMBER SUPERSEDES ANY AND ALL WIRE COLORS.
PUMP MUST BE SOLIDLY MOUNTED TO FRAME.
SOME PUMPS HAVE A GROUND CABLE THAT IS TO BE ATTACHED TO THE GROUND STUD.

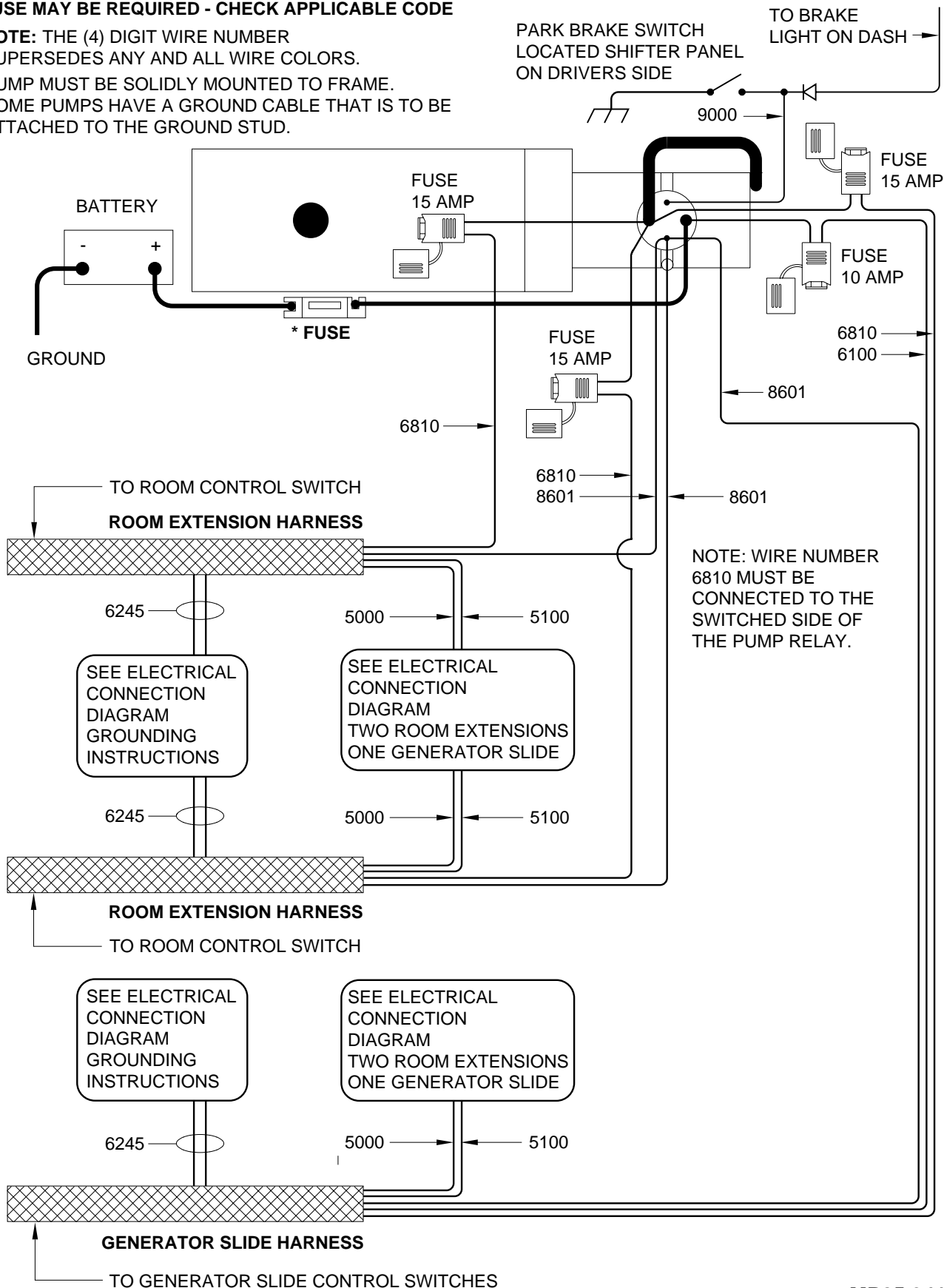

ELECTRICAL SCHEMATIC MONOCO TWO ROOM EXTENSION SYSTEM WITH BAY DOOR SWITCHES

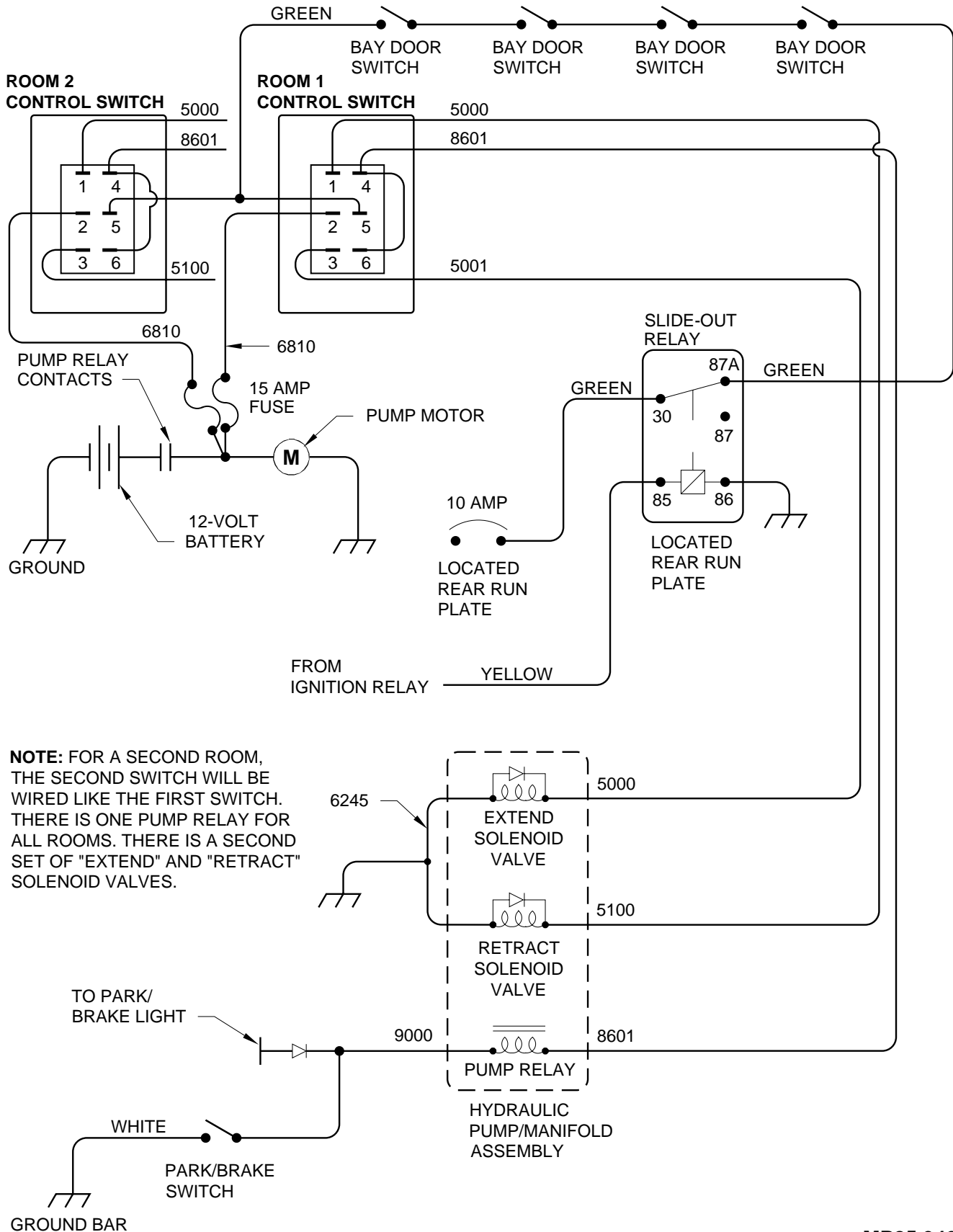

ELECTRICAL CONNECTION DIAGRAM

GROUNDING INSTRUCTIONS

NOTE: IF THE PUMP BRACKET IS WELDED TO FRAME, USE THE GROUND STUD TO ATTACH THE PUMP TO THE BRACKET. IF THE PUMP BRACKET IS BOLTED TO THE FRAME, USE THE GROUND STUD TO ATTACH THE BRACKET TO THE FRAME.

NOTE: THE FOUR DIGIT WIRE NUMBER SUPERSEDES ANY AND ALL WIRE COLORS.

