



# OPERATOR'S MANUAL

## HWH COMPUTER-CONTROLLED LEVELING SYSTEM 610 SERIES

FEATURING:

*TOUCH PANEL CONTROL*

*HYDRAULIC LEVELING*

*AUTOMATIC SUSPENSION AIR DUMP*

*STRAIGHT-ACTING JACKS*

*DUAL CYLINDER "FLAT FLOOR" ROOM EXTENSION*

*FOUR CYLINDER ROOM EXTENSION*

*(WITH SYNCHRONIZING CYLINDER)*

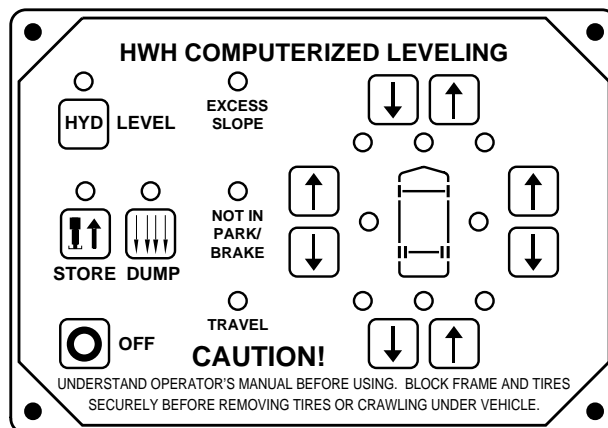

**HWH CORPORATION**  
**(ON I-80, EXIT 267 SOUTH)**  
**2096 MOSCOW ROAD**  
**MOSCOW, IOWA 52760**

**(800) 321-3494 / (563) 724-3396**

**INTERNET: <http://www.hwhcorp.com>**

---

# OPERATING MANUAL

---

## CAUTION !

**READ THE ENTIRE OPERATOR'S MANUAL BEFORE OPERATING.**

**BLOCK FRAME AND TIRES SECURELY BEFORE CRAWLING UNDER VEHICLE. DO NOT USE LEVELING JACKS OR AIR SUSPENSION TO SUPPORT VEHICLE WHILE UNDER VEHICLE OR CHANGING TIRES. VEHICLE MAY DROP AND/OR MOVE FORWARD OR BACKWARD WITHOUT WARNING CAUSING INJURY OR DEATH.**

**KEEP ALL PEOPLE CLEAR OF VEHICLE WHILE LEVELING SYSTEM AND ROOM EXTENSION ARE BEING OPERATED.**

**NEVER PLACE HANDS OR OTHER PARTS OF THE BODY NEAR HYDRAULIC LEAKS. OIL MAY PENETRATE SKIN CAUSING INJURY OR DEATH.**

**WEAR SAFETY GLASSES WHEN INSPECTING OR SERVICING THE SYSTEM TO PROTECT EYES FROM DIRT, METAL CHIPS, OIL LEAKS, ETC. FOLLOW ALL OTHER APPLICABLE SHOP SAFETY PRACTICES.**

**IMPORTANT: IF COACH IS EQUIPPED WITH A ROOM EXTENSION, READ ROOM EXTENSION SECTION BEFORE OPERATING LEVELING SYSTEM.**

## HOW TO OBTAIN WARRANTY SERVICE

### THIS IS NOT TO BE INTERPRETED AS A STATEMENT OF WARRANTY

HWH CORPORATION strives to maintain the highest level of customer satisfaction. Therefore, if you discover a defect or problem, please do the following:

**FIRST:** Notify the dealership where you purchased the vehicle or had the leveling system installed. Dealership management people are in the best position to resolve the problem quickly. If the dealer has difficulty solving the problem, he should immediately contact the Customer Service Department, at HWH CORPORATION.

**SECOND:** If your dealer cannot or will not solve the problem, notify the Customer Service Department:  
HWH CORPORATION 2096 Moscow Rd. Moscow IA. 52760  
(563) 724-3396 OR (800) 321-3494. Give your name and address, coach manufacturer and model year, date the coach was purchased, or the date of system installation,

description of the problem, and where you can be reached during business hours (8:00 a.m. till 5:00 p.m. c.s.t.). HWH CORPORATION personnel will contact you to determine whether or not your claim is valid. If it is, HWH CORPORATION will authorize repair or replacement of the defective part, either by appointment at the factory or by the authorization of an independent service facility, to be determined by HWH CORPORATION. All warranty repairs must be performed by an independent service facility authorized by HWH CORPORATION, or at the HWH CORPORATION factory, unless prior written approval has been obtained from proper HWH CORPORATION personnel.

# CONTROL IDENTIFICATION

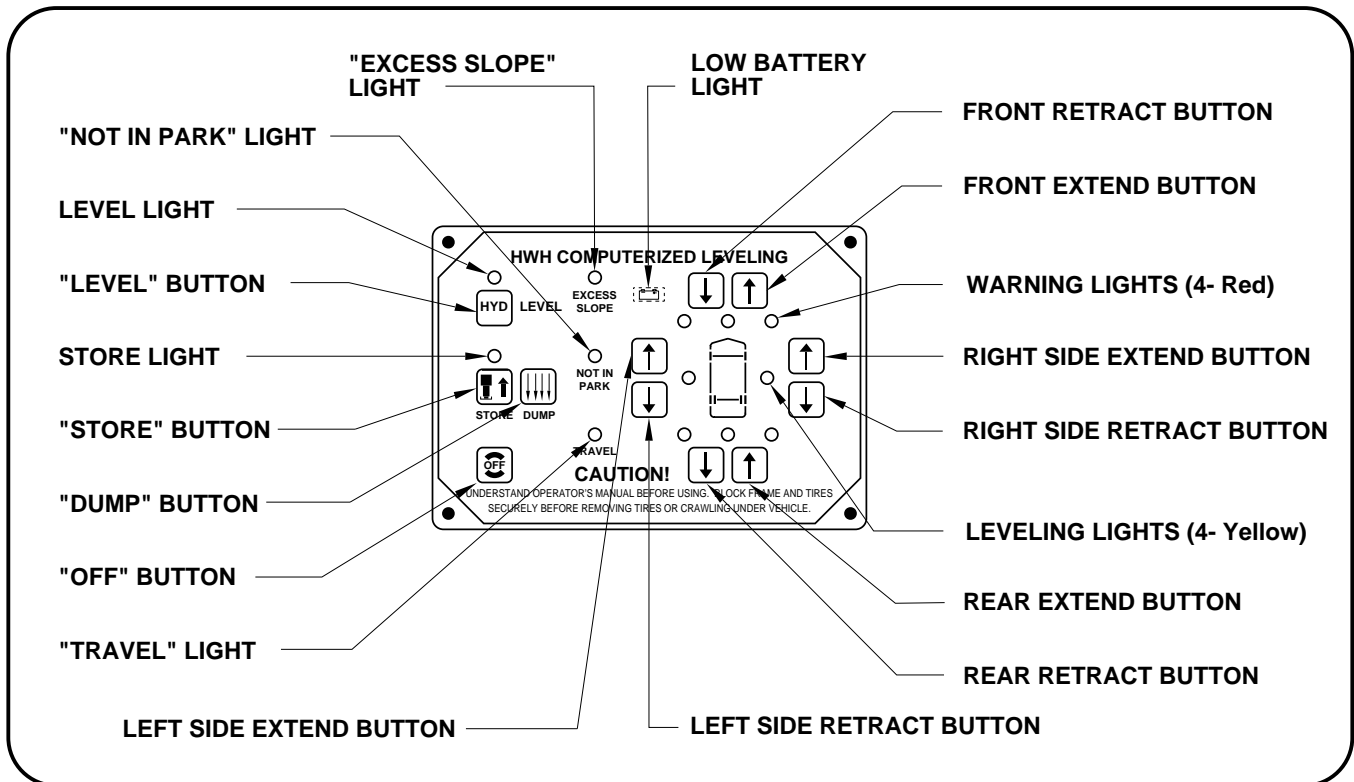

## CONTROL FUNCTIONS

### CONTROL BUTTONS

**"OFF" BUTTON:** Push the "OFF" button to stop hydraulic operation.

**"LEVEL" BUTTON:** This is the on button and automatic operation button. The on indicator light is above the "HYD" button.

**"STORE" BUTTON:** The store indicator light is above the "STORE" button. This button is used to automatically retract the jacks.

**"DUMP" BUTTON:** This is a manual button for dumping air from the vehicle suspension. See MANUAL AIR DUMP Section.

**EXTEND BUTTONS (UP ARROWS):** These buttons will extend their respective jack pairs to lift the vehicle.

**RETRACT BUTTONS (DOWN ARROWS):** These buttons will retract their respective jack pairs to lower the vehicle.

### INDICATOR LIGHTS

**LEVELING LIGHTS :** The four yellow indicating lights are level sensing indicators. When a yellow light is on, it indicates that its side, end, or corner of the vehicle is low. No more than two lights should be on at the same time.

**WARNING LIGHTS:** The four red lights surrounding the yellow level indicators are jacks down WARNING lights. They are functional only when the ignition is in the "ON" or "ACC" position, the system is on, and the jacks are extended 2 or more inches.

**"EXCESS SLOPE" LIGHT:** This indicator will light when the leveling system cannot level the vehicle.

**"NOT IN PARK/BRAKE" LIGHT:** This indicator will light when the panel is on and the hand/auto brake is not set.

**"TRAVEL" LIGHT:** This indicator light will be on when the ignition is on, when the jacks are retracted and there are no red WARNING lights on.

**LOW BATTERY LIGHT:** This indicator will be on when the controller senses low voltage.

**MASTER "JACKS DOWN" WARNING LIGHT:** This is a light mounted in the dash separate from the touch panel. It will be on when any one or more jacks are extended and the ignition is "ON".

**BUZZER:** This is a jacks down warning. It will sound if the master "JACKS DOWN" warning light is on.

---

# OPERATING PROCEDURES

---

## GENERAL INSTRUCTIONS

If parking on soft ground or asphalt paving, wood blocks or pads must be placed under the jacks.

Press the "OFF" button and turn the ignition switch "OFF" at any time to stop the operation of the system.

Any time a hydraulic leveling process is interrupted, retract the jacks according to the JACK RETRACTION Section and then restart the leveling process.

If the "LOW BATTERY" indicator is on, the system should be checked. Battery voltage should be checked, also all connections should be checked.

If the hand/auto brake is not set when the "HYD" button is pressed, the "NOT IN PARK/BRAKE" light will come on and the system will not operate.

**CAUTION:** DO NOT MOVE THE VEHICLE IF A WARNING LIGHT OR BUZZER IS ON.

If a master warning light or buzzer comes on while traveling, turn the leveling system panel on and push the "STORE" button. Due to thermal expansion a jack can extend slightly. See "JACK RETRACTION" section OPERATING PROCEDURES.

## AIR DUMP OPERATION

The manual "DUMP" button is used to manually dump air from the vehicles suspension system. This will lower the vehicle. It can only be used while the vehicle is stationary with the park brake set.

The air dump valves will return to the travel mode if the ignition is on and the park brake is released, or if the leveling system is put in the store mode. This will allow the vehicle to return to the proper ride height.

The "DUMP" button will only work if the leveling system panel is on and the park brake is set. Any time the system is put in the dump mode, whether manually or automatically, it will remain in the dump mode until the park brake is released or the leveling system is put in the store mode.

## PREPARATION FOR TRAVEL

Before traveling, the red jack warning lights must be off and the "TRAVEL" light must be on. If lights are not correct for travel, retract jack as described in the JACK RETRACTION Section.

If the jacks are retracted but a red "WARNING" light is lit or the green "TRAVEL" light is not lit, the system needs to be serviced.

The suspension air bags should be inflated and the vehicle should be at the proper ride height before traveling.

The dump valves will be in the travel mode and the air bags will inflate if the ignition switch is in the "ON" or "ACC" position and the park brake is released, or the if the leveling system is put in the store mode.

**CAUTION:** IT IS THE OWNER'S RESPONSIBILITY TO VISUALLY CHECK THAT THE COACH IS AT THE PROPER RIDE HEIGHT BEFORE TRAVELING.

**CAUTION:** DO NOT MOVE THE VEHICLE WHILE THE LEVELING JACKS ARE STILL IN CONTACT WITH THE GROUND OR IN THE EXTENDED POSITION. THIS VEHICLE IS EQUIPPED WITH STRAIGHT-ACTING JACKS. MOVING THE VEHICLE WITH THE LEVELING JACKS EXTENDED CAN CAUSE SEVERE DAMAGE TO THE JACKS AND OR THE VEHICLE AND CREATE A DRIVING HAZARD. DO NOT RELY SOLELY UPON WARNING LIGHTS. IT IS THE OPERATOR'S RESPONSIBILITY TO VISUALLY CHECK THAT ALL JACKS ARE FULLY RETRACTED INTO THE STORE/TRAVEL POSITION.

If the jacks cannot be retracted according to the JACK RETRACTION Section, retract the jacks according to the MANUAL JACK RETRACTION Section. The system should then should be checked.

**CAUTION:** ALL ROOM EXTENSIONS MUST BE FULLY RETRACTED BEFORE TRAVELING.

## ROOM EXTENSION PROCEDURES

**IMPORTANT:** If the vehicle is equipped with a room extension read this section carefully.

Do NOT operate any room extension until the leveling and stabilizing procedure is complete. Do NOT retract the leveling system until all room extensions are retracted. NEVER operate the leveling system when any room extensions are extended.

Refer to the vehicle owners manual for proper operation of room extensions.

**IMPORTANT:** Do not use a room extension support when the vehicle is supported by the leveling system.

---

# OPERATING PROCEDURES

---

## AUTOMATIC HYDRAULIC LEVELING

1. Place transmission in the recommended position for parking vehicle and set parking brake. Turn the coach engine off. Turn the ignition to the "ACCESSORY" position.
2. Press the "HYD" button to enter the hydraulic operation mode. The "HYD" indicator light will glow steady.
3. At this time, the operator may want to check the jacks and place pads under the jacks if the ground will not support the vehicle.
4. Press the "HYD" button a second time. The "HYD" indicator light will start to flash. The system will begin to dump air from the vehicle suspension. After approximately 45 seconds, the system will automatically extend the jacks to level the vehicle and then extend any remaining jacks until they touch the ground. After the system has finished leveling and stabilizing, it will automatically shut off.

**EXCESS SLOPE SITUATION:** In the event the jacks are unable to level the coach, the "EXCESS SLOPE" indicator light will come on. The pump will shut off. One or two yellow leveling indicator lights will remain on. The "HYD" indicator light will continue to blink for 2 minutes, then the system will shut off. The system will NOT stabilize the vehicle if the "EXCESS SLOPE" light comes on. Store the jacks according to the JACK RETRACTION section. Move the vehicle to a more level position or level the vehicle as close as possible according to the MANUAL HYDRAULIC OPERATION section.

5. Turn the ignition switch to the "OFF" position.

## ROOM EXTEND PROCEDURE

**CAUTION:** OPERATING THE ROOM WITH ANY ROOM-LOCKING DEVICES LOCKED OR THE MANUAL-RETRACT WINCH ATTACHED CAN CAUSE PERSONAL INJURY AND VEHICLE DAMAGE. IT IS THE OPERATOR'S RESPONSIBILITY TO ENSURE THAT ALL ROOM-LOCKING DEVICES AND THE MANUAL-RETRACT WINCH ARE DISENGAGED BEFORE OPERATING THE ROOM.

**IMPORTANT:** It is recommended to level and stabilize the vehicle before extending the room.

**IMPORTANT:** Extending or retracting any leveling jacks when the room is extended is not recommended.

**NOTE:** The park brake must be set. The room will not operate if the park brake is not set.

1. Follow the LEVELING AND STABILIZING PROCEDURE.

**IMPORTANT:** If the leveling system stopped with the "EXCESS SLOPE" light on, see the "EXCESS SLOPE SITUATION" of "AUTOMATIC HYDRAULIC LEVELING".

2. Unlock all room-locking devices.

**NOTE:** If the MANUAL RETRACT WINCH is attached to the room remove it before extending the room.

**CAUTION:** KEEP PEOPLE AND OBSTRUCTIONS CLEAR OF ROOM WHEN OPERATING.

**NOTE:** Make sure there is adequate clearance to fully extend the room.

3. To extend the room, press and hold the ROOM CONTROL SWITCH in the EXTEND position until the room is fully extended.

**NOTE:** Hold the switch to "EXTEND" three or four seconds after the room is fully extended. This assures proper pressurization of the cylinders. **During normal operation of the room, do not reverse direction of the room until the room is fully extended. If necessary, the direction of the room may be reversed, but watch for binding of the room. If the direction of the room has been reversed, DO NOT re-extend the room until the room has been fully retracted.**

**IMPORTANT:** Do not hold the ROOM CONTROL SWITCH in the "EXTEND" position for more than ten seconds after the room is fully extended or stops moving. **If either side of the room stops moving, release the room control switch immediately. DO NOT force the room. DO NOT reverse direction of the room, contact HWH Customer Service for assistance 1-800-321-3494.**

**NOTE:** Releasing the ROOM CONTROL SWITCH will halt the operation of the room.

**IMPORTANT:** Do not use the room extension support when the vehicle is supported by the leveling system.

---

# OPERATING PROCEDURES

---

## ROOM RETRACT PROCEDURE

**CAUTION:** KEEP PEOPLE AND OBSTRUCTIONS CLEAR OF THE ROOM WHEN OPERATING.

**NOTE:** To retract the room the park brake must be set.

1. To retract the room press and hold the ROOM CONTROL SWITCH in the "RETRACT" position until the room is fully retracted.

**NOTE:** The room can be retracted after the leveling system is put in the STORE mode. This will interrupt the STORE mode until the ROOM CONTROL SWITCH is released. The leveling system will continue to STORE starting from the beginning of the program.

**NOTE:** Hold the switch to "RETRACT" three or four seconds after the room is fully retracted. This assures proper pressurization of the cylinders. **During normal operation of the room, do not reverse direction of the room until the room is fully retracted. If necessary, the direction of the room may be reversed, but watch for binding of the room. If the direction of the room has been reversed, DO NOT retract the room until the room has been fully extended.**

**IMPORTANT:** Do not hold the ROOM CONTROL SWITCH in the "RETRACT" position for more than ten seconds after the room is fully retracted or stops moving.

**If either side of the room stops moving, release the room control switch immediately. DO NOT force the room. DO NOT reverse direction of the room, contact HWH Customer Service for assistance 1-800-321-3494.**

**NOTE:** Releasing the ROOM CONTROL SWITCH will halt the operation of the room.

2. Engage all room-locking devices.

3. If the room will not retract see the MANUAL ROOM RETRACT PROCEDURE.

**IMPORTANT:** Room-locking devices should be locked while traveling.

**NOTE:** If the vehicle is parked or stored with the jacks extended for an extended period of time and the jacks fail to retract completely, extend the jacks back down to the ground then retract the jacks again.

---

# OPERATING PROCEDURES

---

## JACK RETRACTION

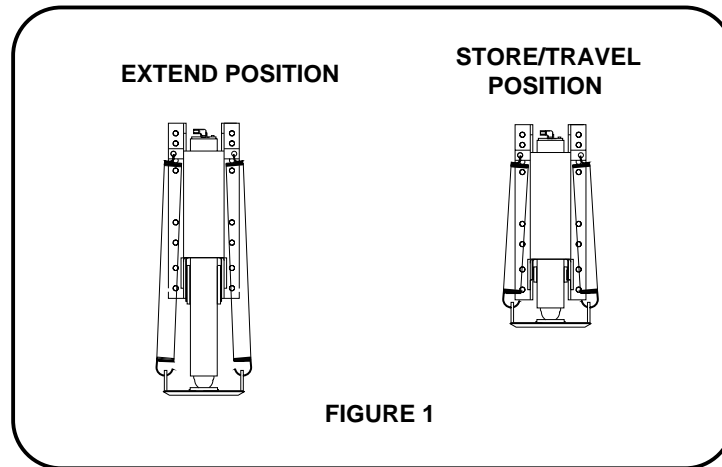

**CAUTION:** THE OPERATOR MUST BE SURE THAT THERE ARE NO OBJECTS UNDER THE VEHICLE AND THAT ALL PEOPLE ARE CLEAR OF THE VEHICLE.

1. Start the engine to build air pressure in the suspension system. Press the "HYD" button and store the jacks immediately.
2. Press the "STORE" button. The store indicator light will flash. As each jack retracts, its red WARNING light will go out. The vehicle can be moved as soon as the red WARNING lights are out and the green "TRAVEL" light is on, providing the jacks are in the STORE/TRAVEL position and the room is fully retracted. (See FIGURE 1)

**IMPORTANT:** DO NOT interrupt power to the leveling system while the "STORE" indicator light is blinking. DO NOT push the "OFF" button or turn the ignition key. The system must be allowed to completely finish the store mode. If the engine was started before putting the system in the store mode, the vehicle may be moved when the jacks are in the STORE/TRAVEL position. This will not interrupt the store procedure.

**NOTE:** Pushing the ROOM CONTROL SWITCH to RETRACT will interrupt the STORE mode. The system will continue to STORE after the ROOM CONTROL SWITCH is released.

**CAUTION:** DO NOT MOVE THE VEHICLE WHILE THE LEVELING JACKS OR THE ROOM EXTENSION ARE STILL IN CONTACT WITH THE GROUND OR IN THE EXTEND POSITION. THIS VEHICLE IS EQUIPPED WITH STRAIGHT ACTING JACKS AND A ROOM EXTENSION. MOVING THE VEHICLE WITH THE LEVELING JACKS AND/OR THE ROOM EXTENDED CAN CAUSE SEVERE DAMAGE TO THE JACKS OR THE VEHICLE AND CREATE A DRIVING HAZARD. DO NOT RELY SOLELY ON THE WARNING LIGHTS. IT IS THE OPERATOR'S RESPONSIBILITY TO VISUALLY CHECK THAT ALL JACKS AND THE ROOM EXTENSION ARE FULLY RETRACTED INTO THE STORE/TRAVEL POSITION, AND THAT THE VEHICLE HAS RETURNED TO THE PROPER RIDE HEIGHT FOR TRAVELING.

3. The system will automatically shut down six minutes after the four individual red "WARNING" lights are out. If any one red "WARNING" light does not go out, the system will continue to store for thirty (30) minutes, then shut down regardless of the "WARNING" lights condition.
4. If jacks cannot be retracted by the above procedure see MANUAL JACK RETRACTION section.

**NOTE:** If the vehicle is parked or stored with the jacks extended for an extended period of time and the jacks fail to retract completely, extend the jacks back down to the ground then retract the jacks again.

---

# OPERATING PROCEDURES

---

## MANUAL HYDRAULIC OPERATION

1. Place transmission in the recommended position for parking the vehicle, and set the parking brake. Turn the vehicle engine off. Turn the ignition to the "ACCESSORY" position.
  2. Press the "HYD" button. The indicator light will glow steady.
  3. Place pads under the jack feet if the ground will not support the vehicle on the jacks.
  4. Press the "DUMP" button. The air will exhaust from the suspension system.
  5. The vehicle may be leveled using the manual EXTEND buttons on the right half of the panel. If a yellow LEVEL SENSING light is on, that side or end of the vehicle is low. Jacks will extend (or retract) in pairs to raise (or lower) a side or end of the vehicle. Any jack not used for leveling can be extended to the ground. This provides additional stability against wind and activity in the vehicle.
- IMPORTANT:** Do not continue to push a EXTEND button for more than ten (10) seconds after that pair of jacks are fully extended.
6. When leveling is completed, push the "OFF" button on the leveling panel and turn the ignition switch to the "OFF" position.

## MANUAL JACK RETRACTION

**NOTE:** Use the valve release "T" handles for retracting only if the "STORE" button on the control panel will not retract the jacks for travel.

**CAUTION:** KEEP AWAY FROM THE WHEELS, DO NOT CRAWL UNDER THE VEHICLE, KEEP A SAFE DISTANCE IN FRONT AND REAR OF VEHICLE. THE VEHICLE MAY DROP AND/OR MOVE FORWARD OR BACKWARD WITHOUT WARNING AS THE VALVE RELEASE IS OPERATED.

1. Locate the 4 valve release "T" handles on the solenoid valves. The solenoid valves are located on the pump/valve assembly.
2. Allow clearance for vehicle to lower.
3. Retract the rear jacks by opening the two outer valves. Slowly turn the "T" handles counter clockwise. The handles may turn

easily at first but as an internal spring is compressed, turning may become more difficult. The valves need only to be opened enough to retract the jack.

4. Retract the front jacks by opening the two center valves as described in Step 3.
5. Check that all four jacks are now retracted.
6. Close the valves by turning the release handles clockwise.

Once the internal spring tension has been released, the handles will turn free for several turns. Once the "T" handles are snug, DO NOT tighten the handles past this point as internal damage may occur to the solenoid.

7. The system should now be repaired before using again.

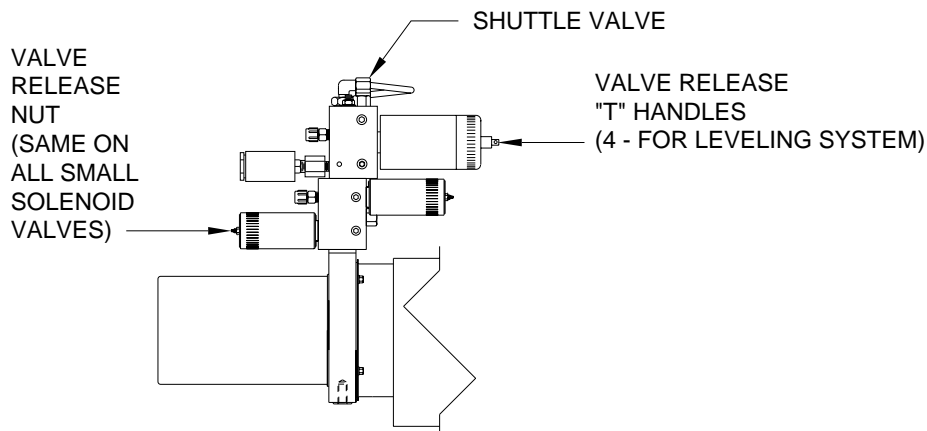



# MANUAL ROOM RETRACT PROCEDURE (WITH SOLENOID VALVES WITH VALVE RELEASE "T" HANDLES)

(USE ONLY WHEN THE ROOM WILL NOT RETRACT WITH THE ROOM CONTROL SWITCH)

## OVERVIEW

The room can be retracted manually if a hydraulic or electrical failure prevents the room from being retracted using the ROOM CONTROL SWITCH. For normal retract sequence see the ROOM RETRACT PROCEDURE.

**CAUTION:** THE MANUAL RETRACT WINCH IS EQUIPPED FOR MANUALLY RETRACTING THE ROOM ONLY. IT IS NOT TO BE USED FOR LIFTING OR ANY OTHER APPLICATION. HIGH FORCES ARE CREATED WHEN USING A WINCH, CREATING POTENTIAL SAFETY HAZARDS. FAILURE TO FOLLOW ALL CAUTIONS AND INSTRUCTIONS MAY CAUSE FAILURE OF THE MANUAL RETRACT WINCH OR CONNECTIONS RESULTING IN DAMAGE OR PERSONAL INJURY. MAINTAIN FIRM GRIP ON THE WINCH HANDLE AT ALL TIMES. NEVER RELEASE THE HANDLE WHEN RATCHET LEVER IS IN THE OFF POSITION AND THE WINCH IS LOADED. THE WINCH HANDLE COULD SPIN VIOLENTLY AND CAUSE PERSONAL INJURY. CHECK THE WINCH AND STRAPS FOR DAMAGE OR WEAR, AND CHECK FOR PROPER RATCHET OPERATION ON EACH USE OF THE WINCH. DO NOT USE IF DAMAGED OR WORN.

1. Retract jacks following the LEVELING SYSTEM RETRACT PROCEDURE.

**NOTE :** When manually retracting the room, make sure the jacks are retracted before retracting the room.

2. Locate the HYDRAULIC PUMP/MANIFOLD unit.

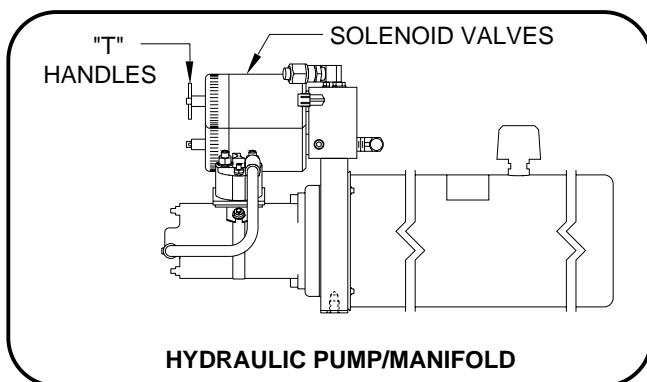

3. Open the SOLENOID VALVES by turning the "T" HANDLES counterclockwise.

**NOTE :** The "T" HANDLE may turn easily at first but will become more difficult to turn as an internal spring is compressed. Be sure to open both valves completely (about six turns of "T" HANDLE).

**NOTE :** The room may move slightly as the SOLENOID VALVES are opened and internal pressure is released.

4. Locate the MANUAL RETRACT WINCH and connect it to the room according to the vehicle manufacturer's instructions. To extend the WINCH STRAP firmly grasp WINCH HANDLE, place RATCHET LEVER in its OFF position, and slowly rotate the WINCH HANDLE counterclockwise, keeping a firm grip on the handle. When enough WINCH STRAP is extended, place the RATCHET LEVER in its ON position and slowly rotate the WINCH HANDLE clockwise until the RATCHET LEVER locks.

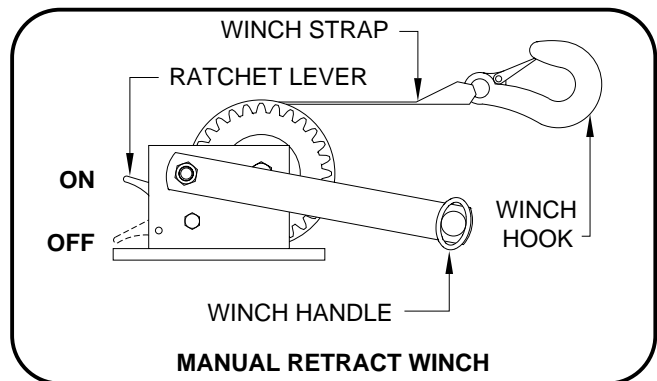

5. Slowly winch the room in by turning the WINCH HANDLE clockwise. The RATCHET LEVER should produce a loud, sharp, clicking noise.

**NOTE :** Winching the room in quickly will raise pressure in the hydraulic fluid and make winching more difficult.

**CAUTION:** OPERATE THE MANUAL RETRACT WINCH BY HAND POWER ONLY. IF THE WINCH CANNOT BE CRANKED EASILY WITH ONE HAND IT IS PROBABLY OVERLOADED. IF WINCHING BECOMES TOO DIFFICULT STOP AND CHECK FOR OBSTRUCTIONS OR RESTRICTIONS ON THE ROOM AND ROOM EXTENSION MECHANISM.

6. When the room is fully retracted, engage the room locking devices. Leave the retract winch in place.

**CAUTION:** THE ROOM EXTENSION SOLENOID VALVE "T" HANDLES MUST BE IN THE OPEN POSITION WHEN THE MANUAL RETRACT WINCH IS ENGAGED.

7. The system should be repaired before using again.

# MANUAL ROOM AND GENERATOR SLIDE RETRACT PROCEDURE (WITH SOLENOID VALVES WITH VALVE RELEASE NUTS)

(USE ONLY WHEN THE ROOM WILL NOT RETRACT WITH THE ROOM CONTROL SWITCH)

## OVERVIEW

The room can be retracted manually if a hydraulic or electric failure prevents the room from being retracted using the CONTROL SWITCH. For normal retract sequence see the ROOM SLIDE RETRACT PROCEDURES. Refer to the vehicle manufacturer for storage location of the winch and information for connecting the winch to the room.

**IMPORTANT:** If the vehicle is not equipped with a winch, DO NOT use other pulling devices to retract the room. Follow steps 2 and 3 and try pushing the room in. Contact the vehicle manufacturer or HWH Customer Service at 1-800-321-3494 or 563-724-3396 for assistance.

**CAUTION:** THE MANUAL RETRACT WINCH IS EQUIPPED FOR MANUALLY RETRACTING THE ROOM ONLY. IT IS NOT TO BE USED FOR LIFTING OR ANY OTHER APPLICATION. HIGH FORCES ARE CREATED WHEN USING A WINCH, CREATING POTENTIAL SAFETY HAZARDS. FAILURE TO FOLLOW ALL CAUTIONS AND INSTRUCTIONS MAY CAUSE FAILURE OF THE MANUAL RETRACT WINCH OR CONNECTIONS RESULTING IN DAMAGE OR PERSONAL INJURY. MAINTAIN FIRM GRIP ON THE WINCH HANDLE AT ALL TIMES. NEVER RELEASE THE HANDLE WHEN RATCHET LEVER IS IN THE OFF POSITION AND THE WINCH IS LOADED. THE WINCH HANDLE COULD SPIN VIOLENTLY AND CAUSE PERSONAL INJURY. CHECK THE WINCH AND STRAPS FOR DAMAGE OR WEAR, AND CHECK FOR PROPER RATCHET OPERATION ON EACH USE OF THE WINCH. DO NOT USE IF DAMAGED OR WORN.

1. Retract jacks following the LEVELING SYSTEM RETRACT PROCEDURE.

**NOTE :** When manually retracting the room, make sure the jacks are retracted before retracting the room.

2. Locate the HYDRAULIC PUMP/MANIFOLD unit.

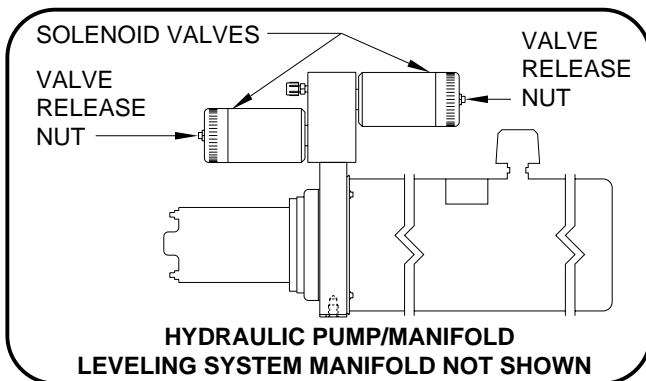

3. Open the Solenoid Valves by slowly turning the valve release nuts counter clockwise using the 1/4" nut driver supplied.

**IMPORTANT:** Only open the valves enough to retract the room. DO NOT turn the release nuts more than 4 and 1/2 turns. Turning the nuts more could damage the valves.

**NOTE:** Prior to APRIL 2002 a 1/4" Nut Driver was sent with the Operators Manual. As of APRIL 2002 the 1/4" Nut Driver has been incorporated into the Breather Cap. See the back page of this manual for further info.

**NOTE:** The room may move slightly as the SOLENOID VALVES are opened and internal pressure is released.

4. Locate the MANUAL RETRACT WINCH and connect it to the room according to the vehicle manufacturer's instructions. To extend the WINCH STRAP firmly grasp WINCH HANDLE, place RATCHET LEVER in its OFF position, and slowly rotate the WINCH HANDLE counter clockwise, keeping a firm grip on the handle. When enough WINCH STRAP is extended, place the RATCHET LEVER in its ON position and slowly rotate the WINCH HANDLE clockwise until the RATCHET LEVER locks.

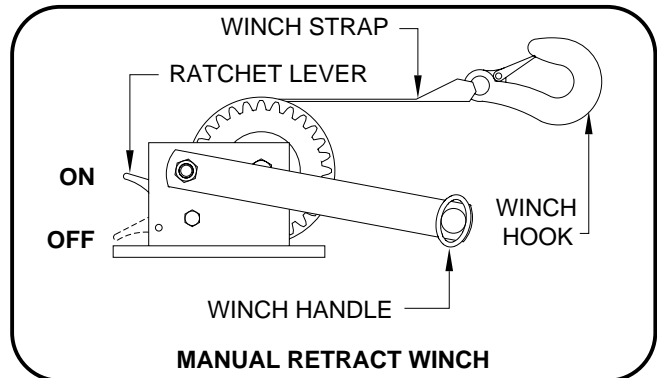

5. Slowly winch the room in by turning the WINCH HANDLE clockwise. The RATCHET LEVER should produce a loud, sharp, clicking noise.

**NOTE:** Winching the room in quickly will raise pressure in the hydraulic fluid and make winching more difficult.

**CAUTION:** OPERATE THE MANUAL RETRACT WINCH BY HAND POWER ONLY. IF THE WINCH CANNOT BE CRANKED EASILY WITH ONE HAND IT IS PROBABLY OVERLOADED. IF WINCHING BECOMES TOO DIFFICULT STOP AND CHECK FOR OBSTRUCTIONS OR RESTRICTIONS ON THE ROOM AND ROOM EXTENSION MECHANISM.

6. When the room is fully retracted, engage the room locking devices. Leave the retract winch engaged and the solenoid valves open.

**CAUTION:** THE ROOM EXTENSION SOLENOID VALVE RELEASE NUTS MUST BE IN THE OPEN POSITION WHEN THE MANUAL RETRACT WINCH IS ENGAGED.

7. The system should be repaired before using again.

**NOTE:** After repairs are made, when closing the VALVE RELEASE NUTS, do not over tighten the nuts.

MP35.952D  
01MAY02

---

# MAINTENANCE

---

## OIL LEVEL

It is important that the four leveling jacks and any room extensions are fully retracted before checking the hydraulic oil level. To check the oil supply, remove the breather cap from the top of the hydraulic oil reservoir. The oil level should be approximately one inch below the top of the reservoir when adequately filled.

**FLUID:** HWH Specialty Hydraulic Oil is recommended. In an emergency Dexron automatic transmission fluid can be used.  
**NOTE:** Dexron automatic transmission fluid contains red dye and can cause staining should a leak occur. **DO NOT USE** brake fluid or hydraulic jack fluid. Use of these can damage seals.

## ELECTRICAL SYSTEM

The batteries should be in good condition and fully charged. Weak batteries can cause erratic operation. Battery cable terminals and battery posts and connections should be kept clean.

All electrical connections, especially ground connections, should be clean, tight, free from corrosion and protected from weathering.

## UNUSUAL CONDITIONS

If driving conditions are unusually muddy, the jacks may become caked or clogged with mud. This condition may hamper the proper operation of the leveling system. This problem may be prevented or remedied by cleaning off each leveling jack if they become excessively muddy.

Do not move the vehicle while the leveling jacks are still in contact with ground. Retract the jacks according to the "JACK RETRACTION" section and then visually check to see if the leveling jacks have returned to the STORE/TRAVEL position.

In wet or icy weather leveling jacks may become encrusted with ice. This may cause the leveling system to function improperly. To eliminate this problem, periodically check the leveling jacks and break loose any ice which may be causing improper operation.

**NOTE:** All major components of the system can be replaced with rebuilt parts or can be sent to HWH CORPORATION to be rebuilt, when the system is out of warranty.

## OPERATIONAL CHECK

**Review the Operator's manual and run the system in the automatic and manual mode. Note any abnormal operation.**

Check that all lights work according to the INDICATOR LIGHT section. Correct function of the four red WARNING lights is essential to the correct operation of the system.

Check that the vehicle is level when all the yellow LEVEL indicator lights are out.

**NOTE:** The level sensing unit has an accuracy tolerance of + or - 1 inch side to side, and + or - 5.4 inches front to rear on a 36 foot vehicle.

If the red LOW BATTERY indicator light comes on, the electrical system should be checked. If the light comes on, the operation of the system is not interrupted, but low voltage can cause erratic operation or damage components. Contact your dealer or HWH CORPORATION for assistance.

Check the air dump system by using the manual "DUMP" button according to the AIR DUMP section. If the system will not dump air or return to the proper ride height, contact your dealer or HWH CORPORATION.

**Review the JACK RETRACTION section.**

Make sure the jacks will fully retract to the store position. Jacks should not interfere with any part of the vehicle when in the store position.

With the jacks extended, check that the jacks can be retracted using the "T" handles on the solenoid valves. Refer to the MANUAL JACK RETRACTION section.

# MAINTENANCE

## LEVEL SENSING UNIT ADJUSTMENT

Level the vehicle by placing a circular bubble level in the center of the freezer floor or location within the vehicle that is to be level. With the vehicle level, adjust the sensing unit until all yellow lights are off. This is done by drawing up the corresponding screw if the sensing unit is mounted below the surface as shown or backing out the corresponding screw if the sensing unit is mounted above the surface. Bump the sensing unit to see that it is settled tight against all three screw heads and still indicates that the unit is level.

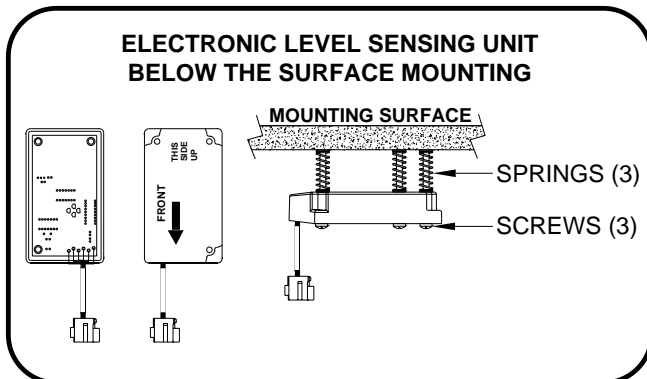
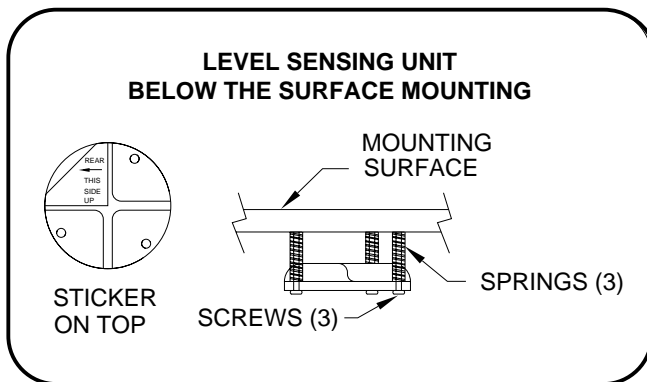

## "NOT IN PARK/BRAKE" CHECK

**CAUTION: WHEN MAKING THIS CHECK, BLOCK THE VEHICLES WHEELS SECURELY SO THE VEHICLE CANNOT ROLL FORWARD OR BACKWARD.**

Set the park brake. Switch the ignition to "ACCESSORY" or "ON" position. Press the "I" button one time. Release the parking brake and confirm that the "NOT IN PARK/BRAKE" indicator light comes on. Reset the parking brake. The "NOT IN PARK/BRAKE" indicator light should go out. Switch the ignition to "OFF".

**NOTE: If any of the previous checks or inspections reveal a problem or if there are other problems or questions, consult a qualified RV repair center, your vehicle or coach manufacturer, or HWH CORPORATION for service or repair.**

---

# TROUBLE SHOOTING ROOM EXTENSION

---

The following is a list of problems, and possible solutions, which might occur to the room extension systems.

**NOTE :** Only qualified technicians should install or repair room systems. A knowledge of hydraulic, welding, the vehicle,s suspension and electrical systems is required. In addition, an understanding of the room extensions system,s hydraulics and electronics is required.

**1. HYDRAULIC PUMP WILL NOT ACTIVATE WHEN ROOM CONTROL SWITCH IS PRESSED.**

- A. KEY SWITCH is in the "OFF" POSITION.
- B. A JACK WARNING LIGHT is not on.
- C. FUSE is blown.
- D. PUMP RELAY and/or HYDRAULIC PUMP are not properly grounded.
- E. 12 VOLT power to pump relay not present.
- F. Faulty wire, electrical connection, KEY SWITCH, ROOM CONTROL SWITCH, PUMP RELAY, or PUMP MOTOR.

**2. HYDRAULIC PUMP ACTIVATES, BUT ROOM WILL NOT EXTEND.**

- A. EXTEND SOLENOID VALVE is not properly grounded.
- B. Reservoir oil supply is low.
- C. Hydraulic line is pinched or broken.
- D. Faulty wire, electrical connection, ROOM CONTROL SWITCH , EXTEND SOLENOID VALVE, HYDRAULIC PUMP, or HYDRAULIC CYLINDER.

**3. HYDRAULIC PUMP ACTIVATES, BUT ROOM WILL NOT RETRACT.**

- A. RETRACT SOLENOID VALVE IS NOT properly grounded.
- B. Reservoir oil supply is low.
- C. Hydraulic line is pinched or broken.
- D. Faulty wire, electrical connection, ROOM CONTROL SWITCH , RETRACT SOLENOID VALVE, HYDRAULIC PUMP, or HYDRAULIC CYLINDER.

**4. ROOM CREEPS OUT AFTER CLOSING.**

- A. "T" HANDLE on EXTEND SOLENOID VALVE is not closed completely.
- B. EXTEND SOLENOID VALVE has an internal leak.
- C. HYDRAULIC CYLINDER has an internal leak.
- D. The MANIFOLD CHECK VALVE is leaking.

**5. ROOM CREEPS IN AFTER BEING EXTENDED.**

- A. "T" HANDLE on RETRACT SOLENOID VALVE is not closed completely.
- B. RETRACT SOLENOID VALVE has an internal leak.

# HYDRAULIC LINE CONNECTION DIAGRAM LEVELING SYSTEM

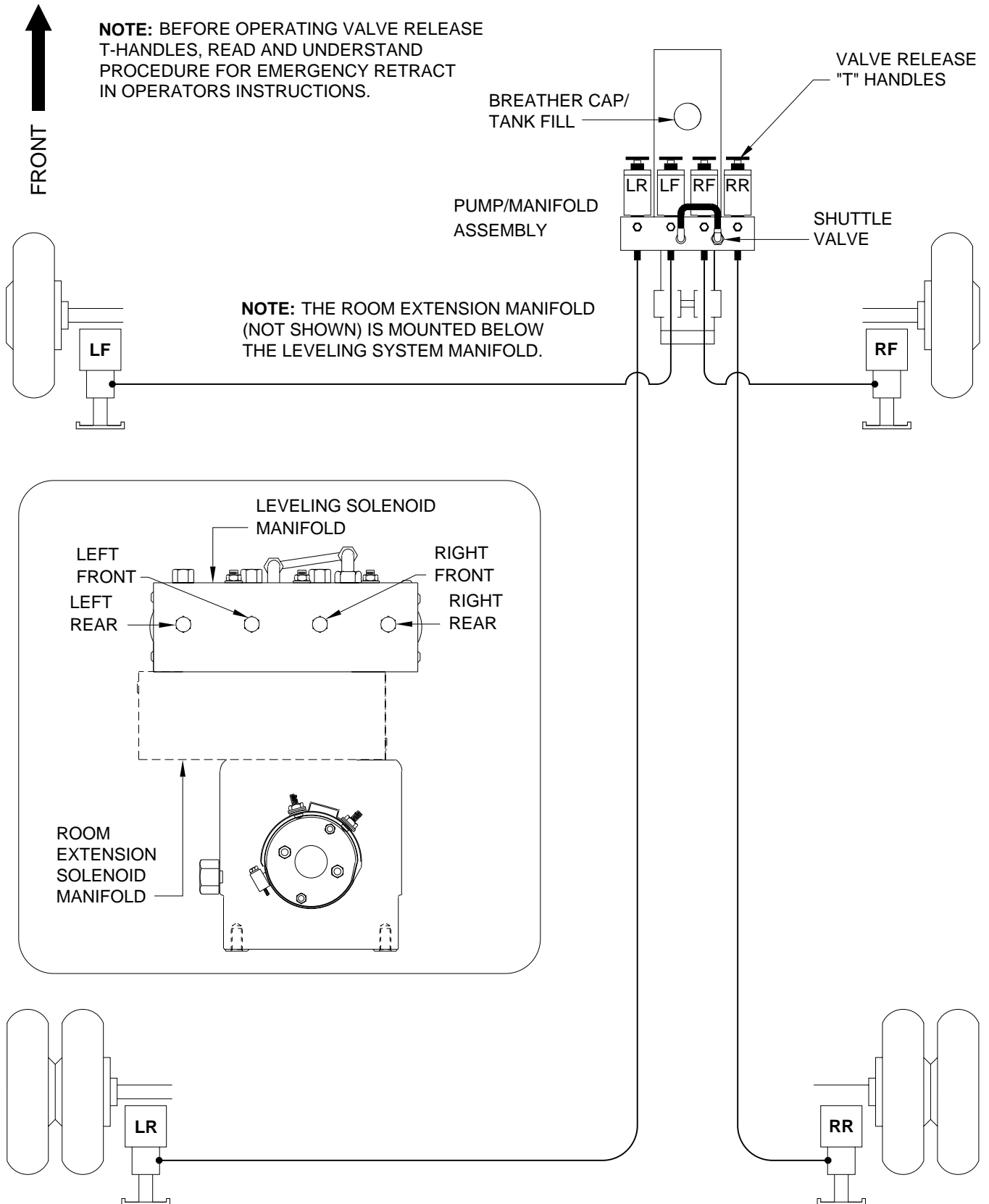

# HYDRAULIC LINE CONNECTION DIAGRAM ROOM EXTENSION - ONE OR TWO ROOMS SOLENOID VALVES WITH VALVE RELEASE "T" HANDLES

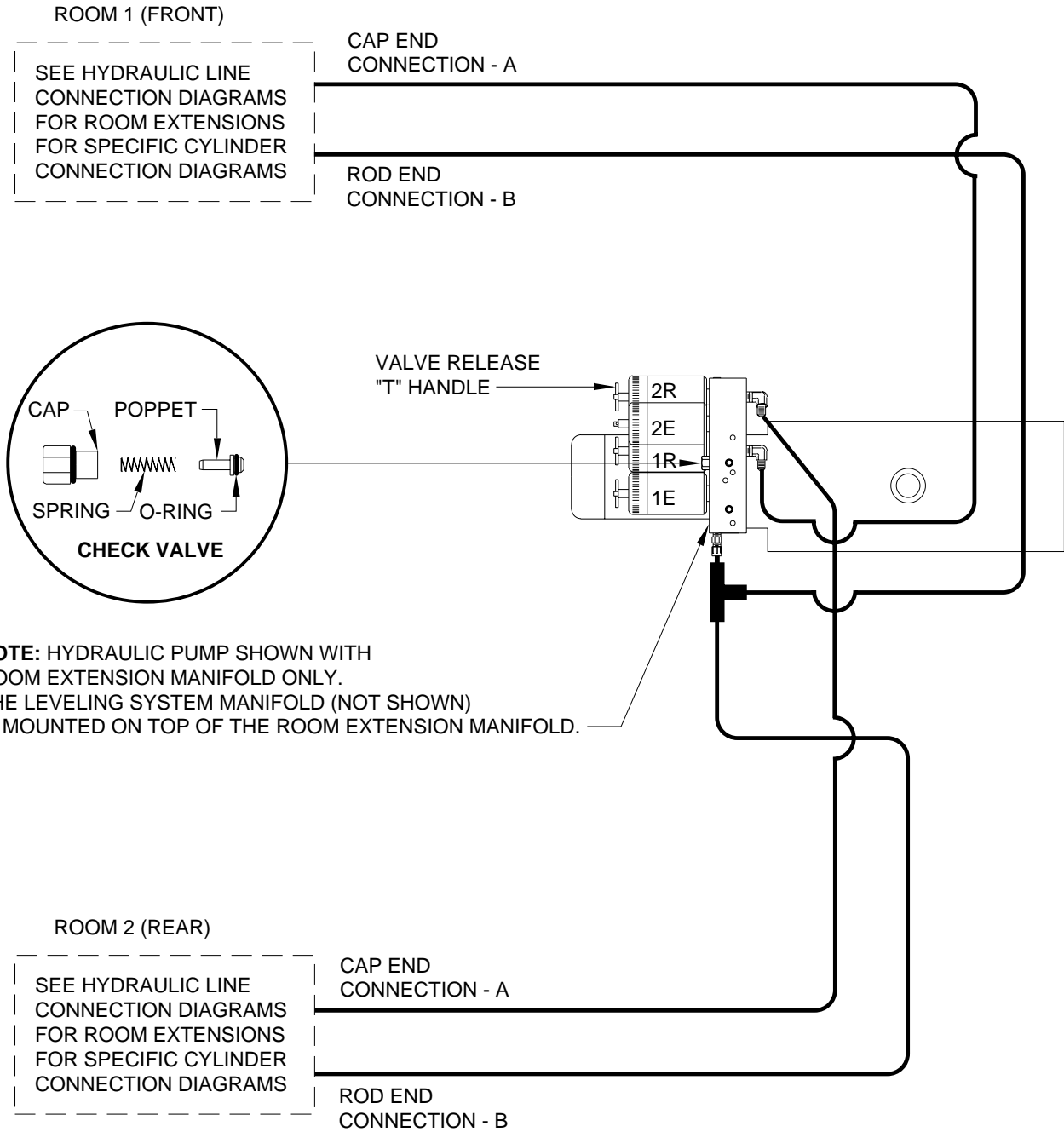

# HYDRAULIC LINE CONNECTION DIAGRAM ROOM EXTENSION - ONE OR TWO ROOMS SOLENOID VALVES WITH VALVE RELEASE NUTS

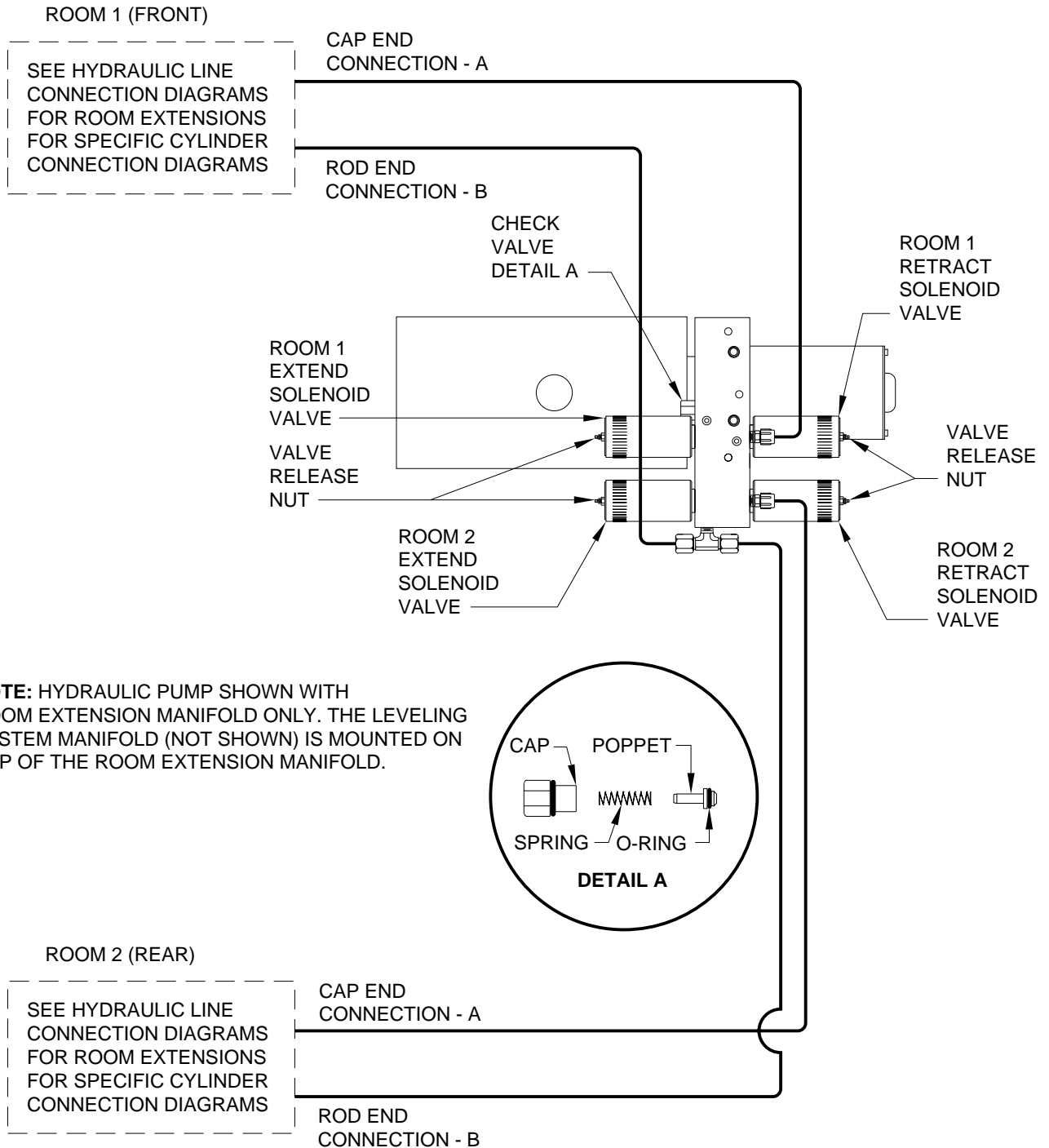



---

# HYDRAULIC LINE CONNECTION DIAGRAM DUAL CYLINDER "FLAT FLOOR" ROOM EXTENSION (WITH SYNCHRONIZING CYLINDER)

---

## DUAL CYLINDER "FLAT FLOOR" ROOM EXTENSION WITH SYNCHRONIZING CYLINDER

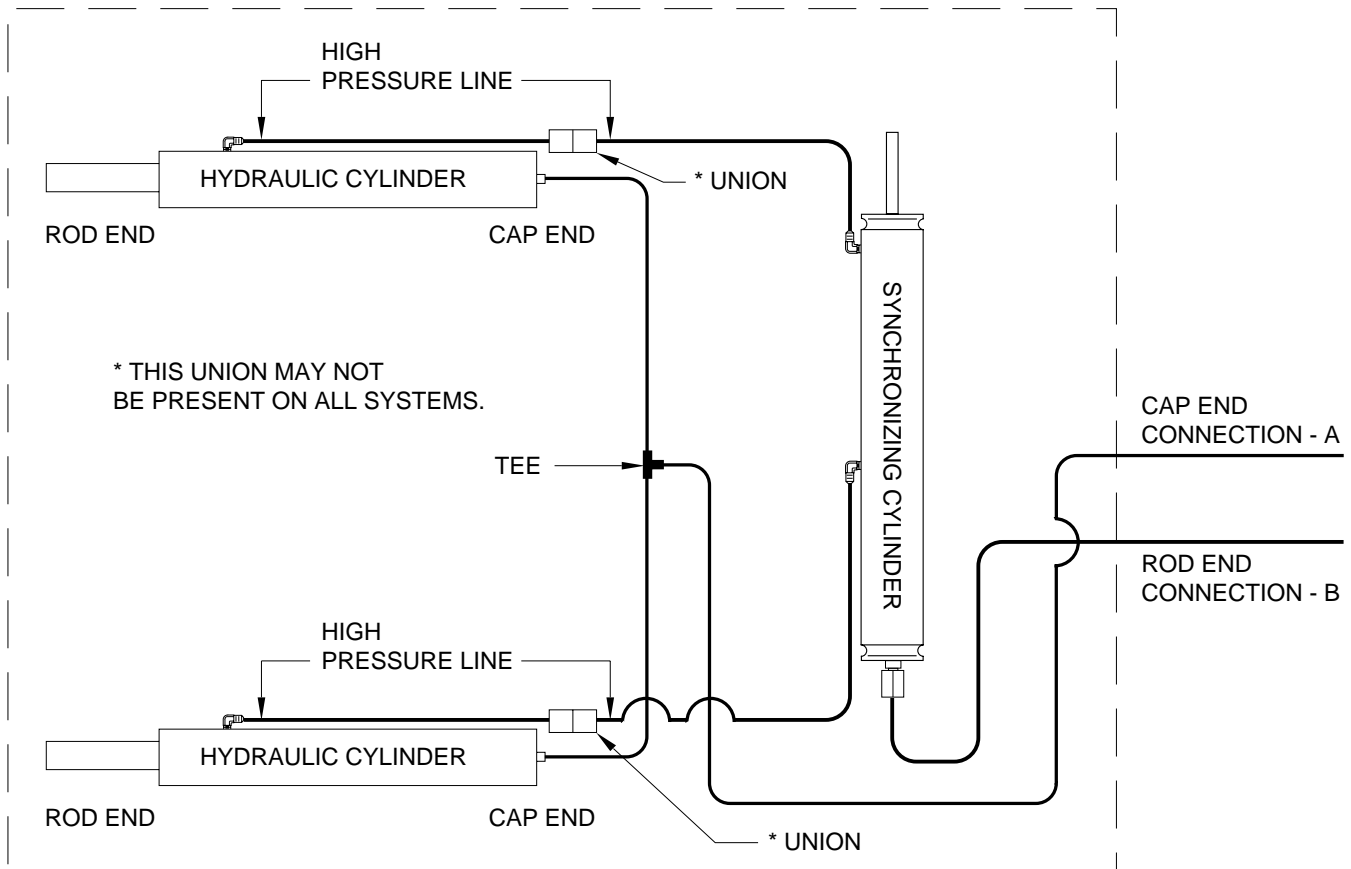

**IMPORTANT:** THE TWO 3/16" HIGH PRESSURE LINES BETWEEN THE SYNCHRONIZING CYLINDER AND THE ROD END OF THE ROOM CYLINDERS MUST BE EQUAL IN LENGTH AND DIAMETER. THE HYDRAULIC LINES BETWEEN THE CAP END OF THE ROOM CYLINDERS AND WHERE THEY TEE TOGETHER MUST BE OF EQUAL LENGTH AND DIAMETER.

**NOTE:** DIFFERENT TYPES OF HOSE, ESPECIALLY HIGH PRESSURE HOSE, HAS BEEN USED. THE PRINTING ON A 1/8" OR 3/16" HOSE BEING REPLACED MUST MATCH THE ORIGINAL HOSE. ALL HWH 1/4" HOSE IS THE SAME.

# HYDRAULIC LINE CONNECTION DIAGRAM FOUR CYLINDER ROOM EXTENSION (WITH SYNCHRONIZING CYLINDER)

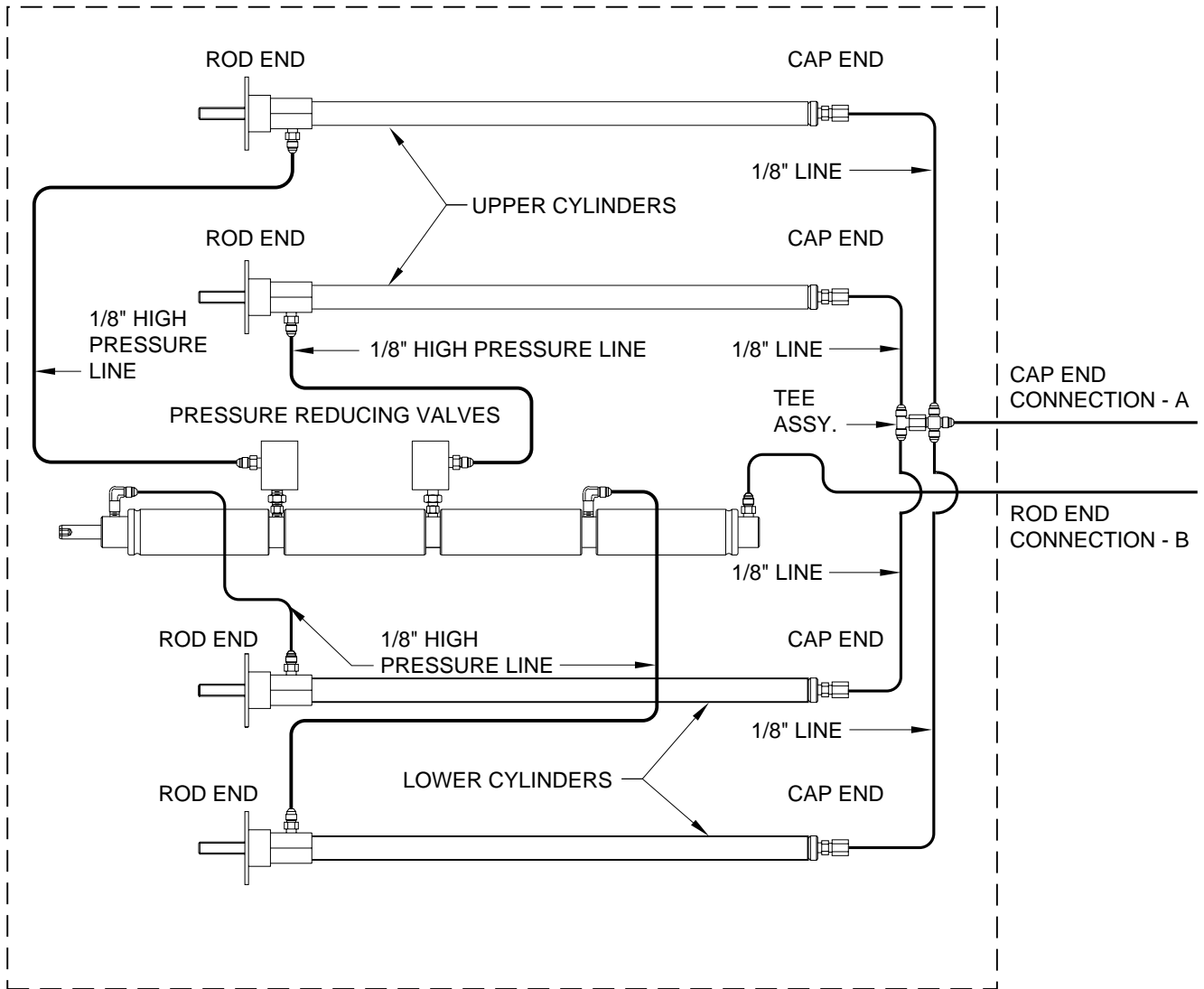

**IMPORTANT:** THE TWO LINES BETWEEN THE CAP END OF THE LOWER CYLINDERS AND THE TEE ASSEMBLY MUST BE THE SAME LENGTH AND DIAMETER.

THE TWO LINES BETWEEN THE ROD END OF THE LOWER CYLINDERS AND THE SYNCHRONIZING CYLINDER MUST BE HIGH PRESSURE HOSE THAT IS THE SAME LENGTH AND DIAMETER.

THE TWO LINES BETWEEN THE CAP END OF THE UPPER CYLINDERS AND THE TEE ASSEMBLY MUST BE THE SAME LENGTH AND DIAMETER.

THE TWO LINES BETWEEN THE ROD END OF THE UPPER CYLINDERS AND THE SYNCHRONIZING CYLINDER MUST BE HIGH PRESSURE HOSE THAT IS THE SAME LENGTH AND DIAMETER.



**NOTE:** THE PRESSURE REDUCING VALVES MAY BE IN A DIFFERENT POSITION ON THE SYNCHRONIZING CYLINDER. THEY WILL ALWAYS CONNECT TO THE ROD END OF THE UPPER CYLINDERS.

# HYDRAULIC SCHEMATIC

## BI-AXIS LEVELING WITH STRAIGHT-ACTING JACKS

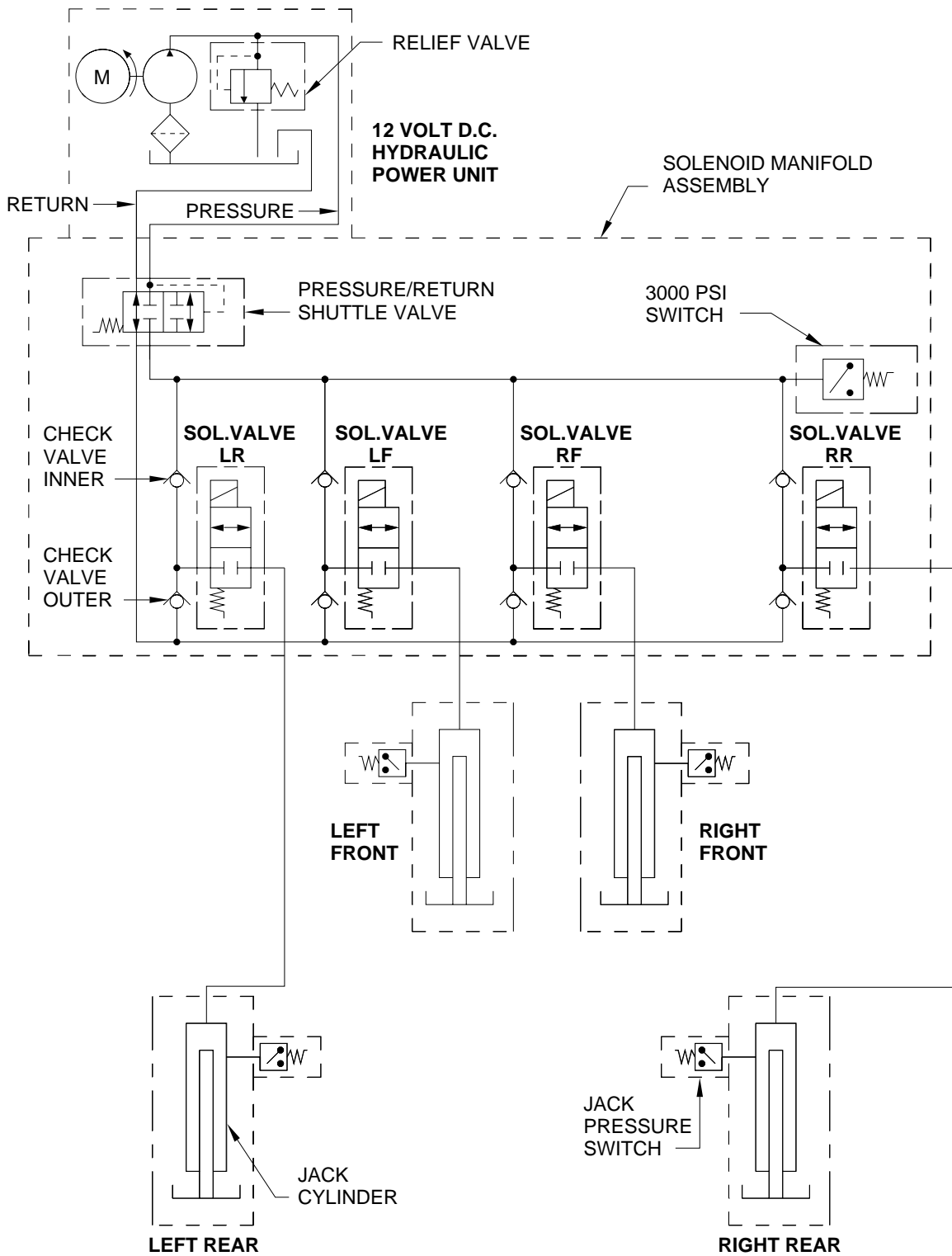

**HYDRAULIC FLOW DIAGRAM  
VERTICAL ARM OR DUAL CYLINDER ROOM EXTENSION  
WITH SYNCHRONIZING CYLINDER  
STATIONARY POSITION**

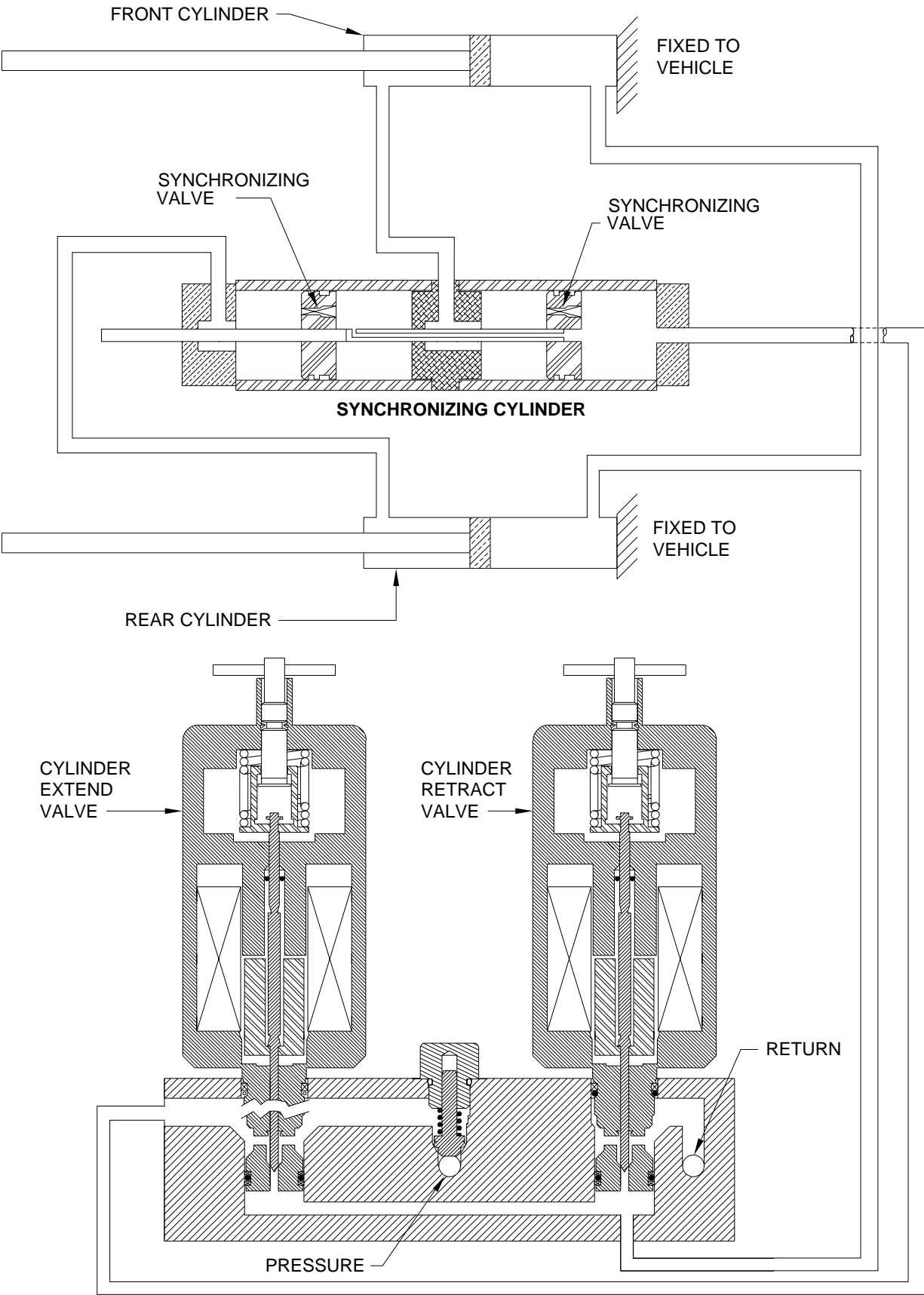

# HYDRAULIC FLOW DIAGRAM FOUR CYLINDER ROOM EXTENSION WITH SYNCHRONIZING CYLINDER

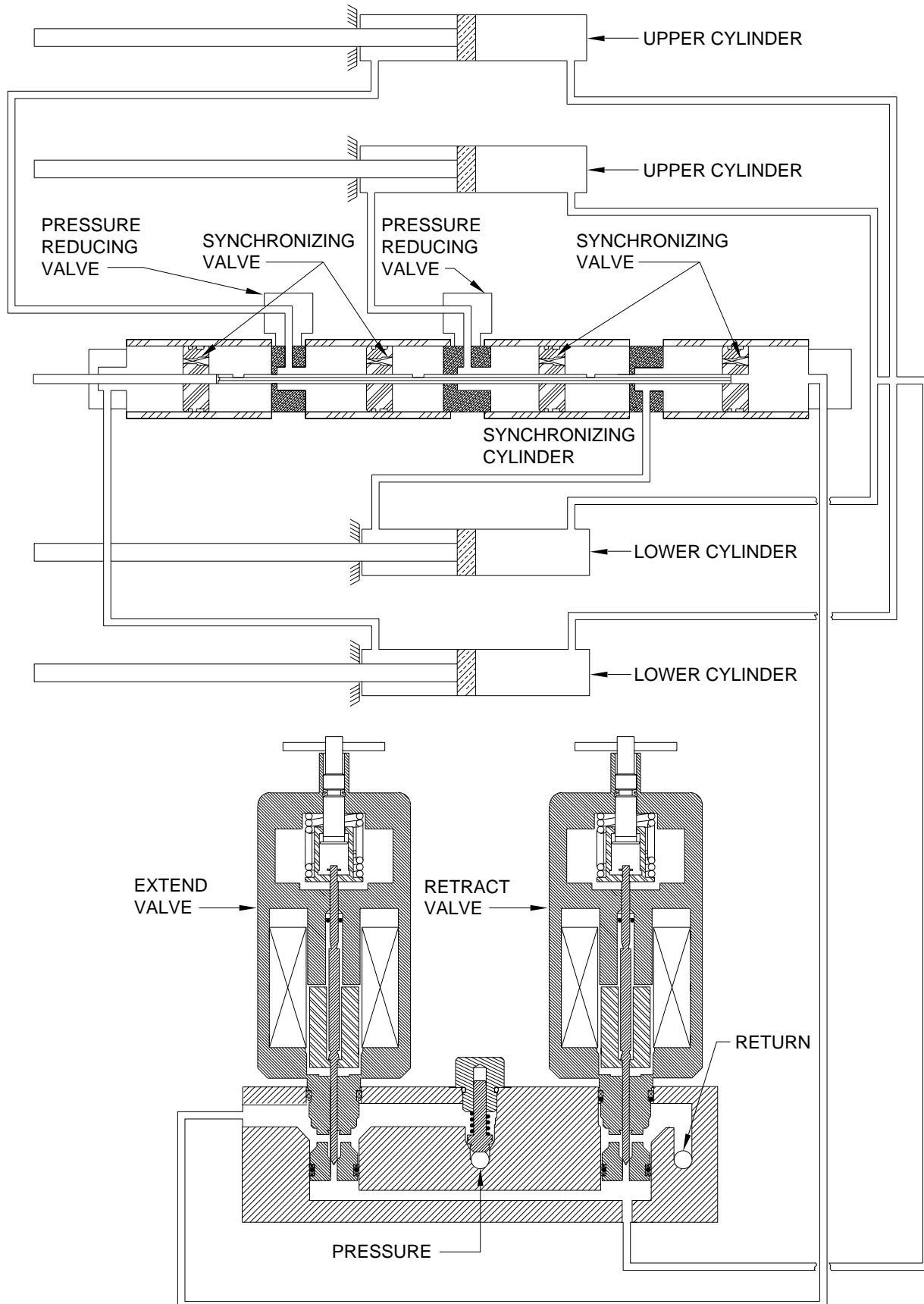

# ELECTRICAL CONNECTION DIAGRAM HYDRAULIC MANIFOLD 610 SERIES LEVELING SYSTEM

## MANIFOLD DIAGRAM

VIEW FROM TOP

DO NOT REVERSE WIRE  
COLORS TO A & B ON  
PACKARD CONNECTORS !

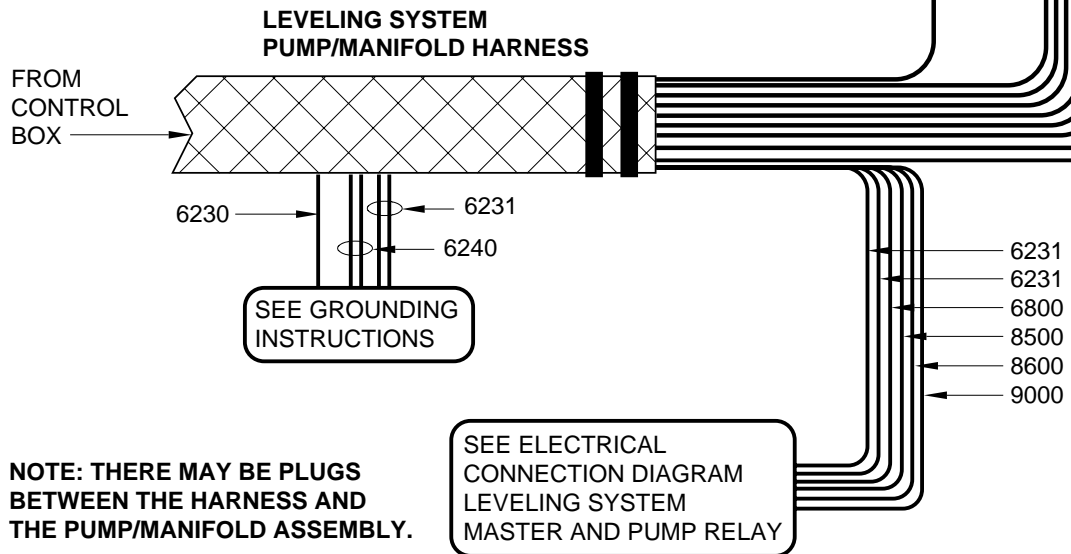
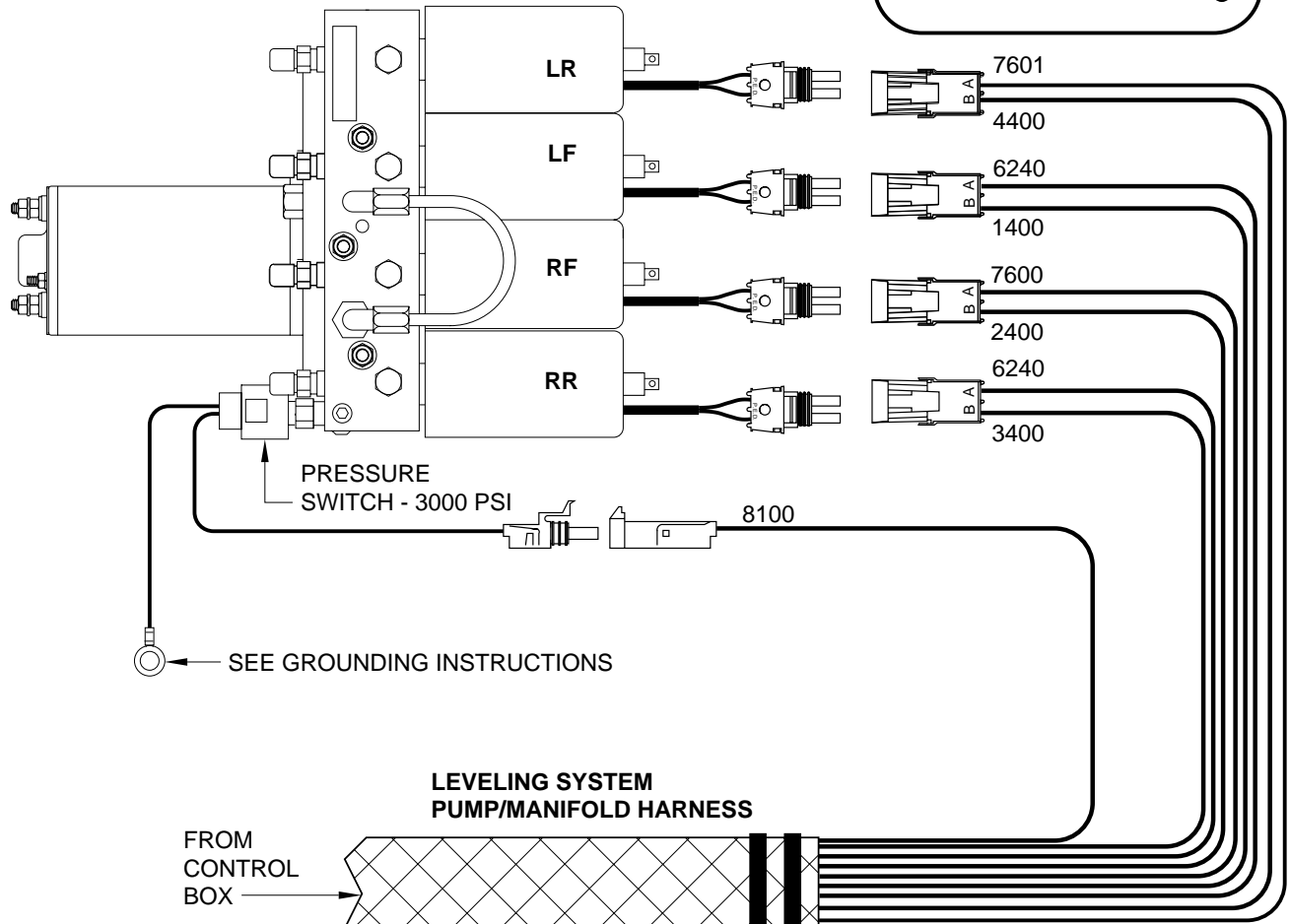

**NOTE: THERE MAY BE PLUGS  
BETWEEN THE HARNESS AND  
THE PUMP/MANIFOLD ASSEMBLY.**

SEE ELECTRICAL  
CONNECTION DIAGRAM  
LEVELING SYSTEM  
MASTER AND PUMP RELAY

# ELECTRICAL CONNECTION DIAGRAM

## 610 SERIES HYDRAULIC LEVELING SYSTEM

### WITH TOUCH PANEL CONTROLS AIR DUMP - AND ROOM EXTENSION

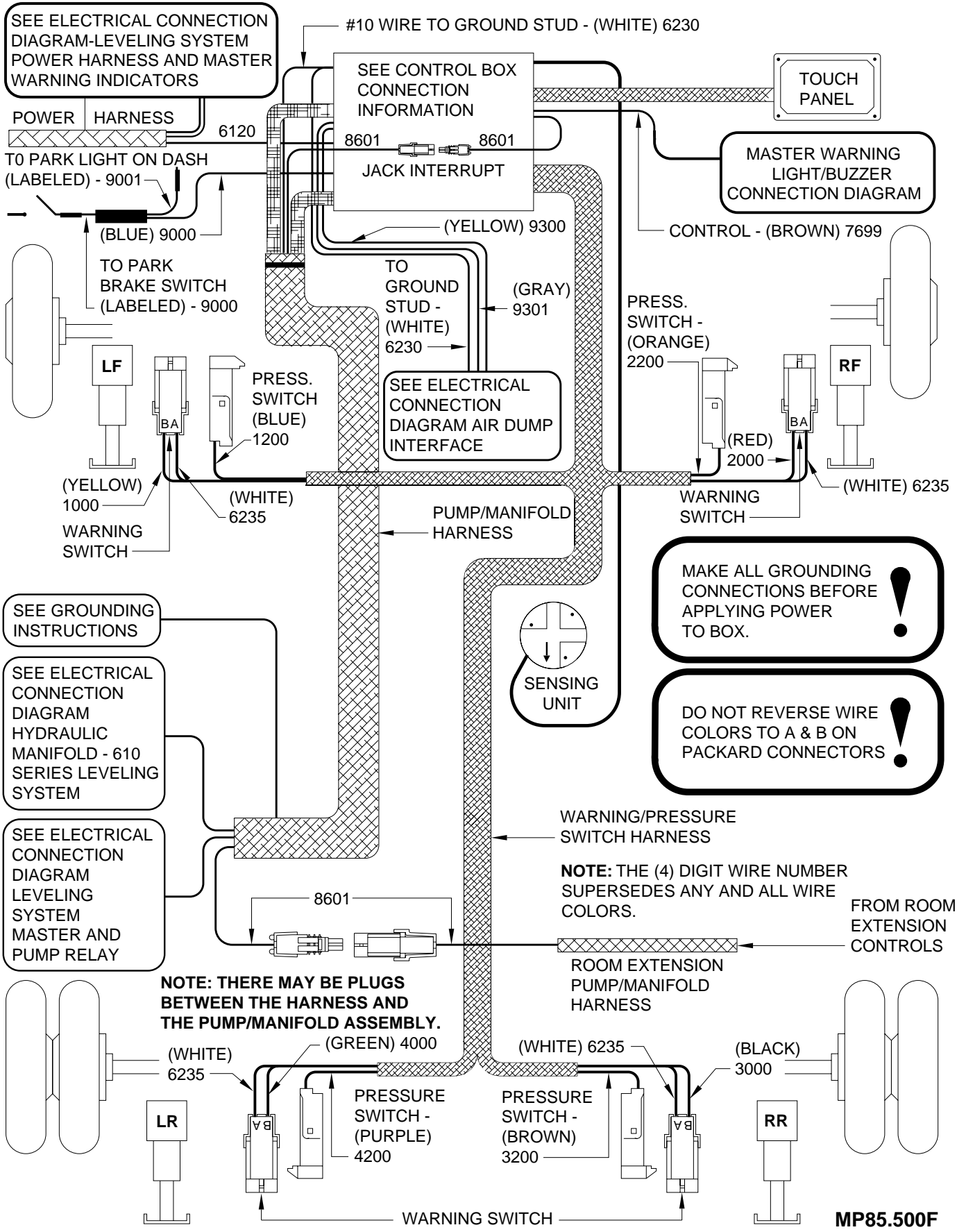

**MAKE ALL GROUNDING CONNECTIONS BEFORE APPLYING POWER TO BOX.**

**DO NOT REVERSE WIRE COLORS TO A & B ON PACKARD CONNECTORS**

**NOTE: THERE MAY BE PLUGS BETWEEN THE HARNESS AND THE PUMP/MANIFOLD ASSEMBLY.**

**NOTE: THE (4) DIGIT WIRE NUMBER SUPERSEDES ANY AND ALL WIRE COLORS.**

FROM ROOM EXTENSION CONTROLS

# CONTROL BOX CONNECTION INFORMATION

## 610 SERIES LEVELING SYSTEMS

### WITH PILOT AIR DUMP AND ROOM EXTENSIONS

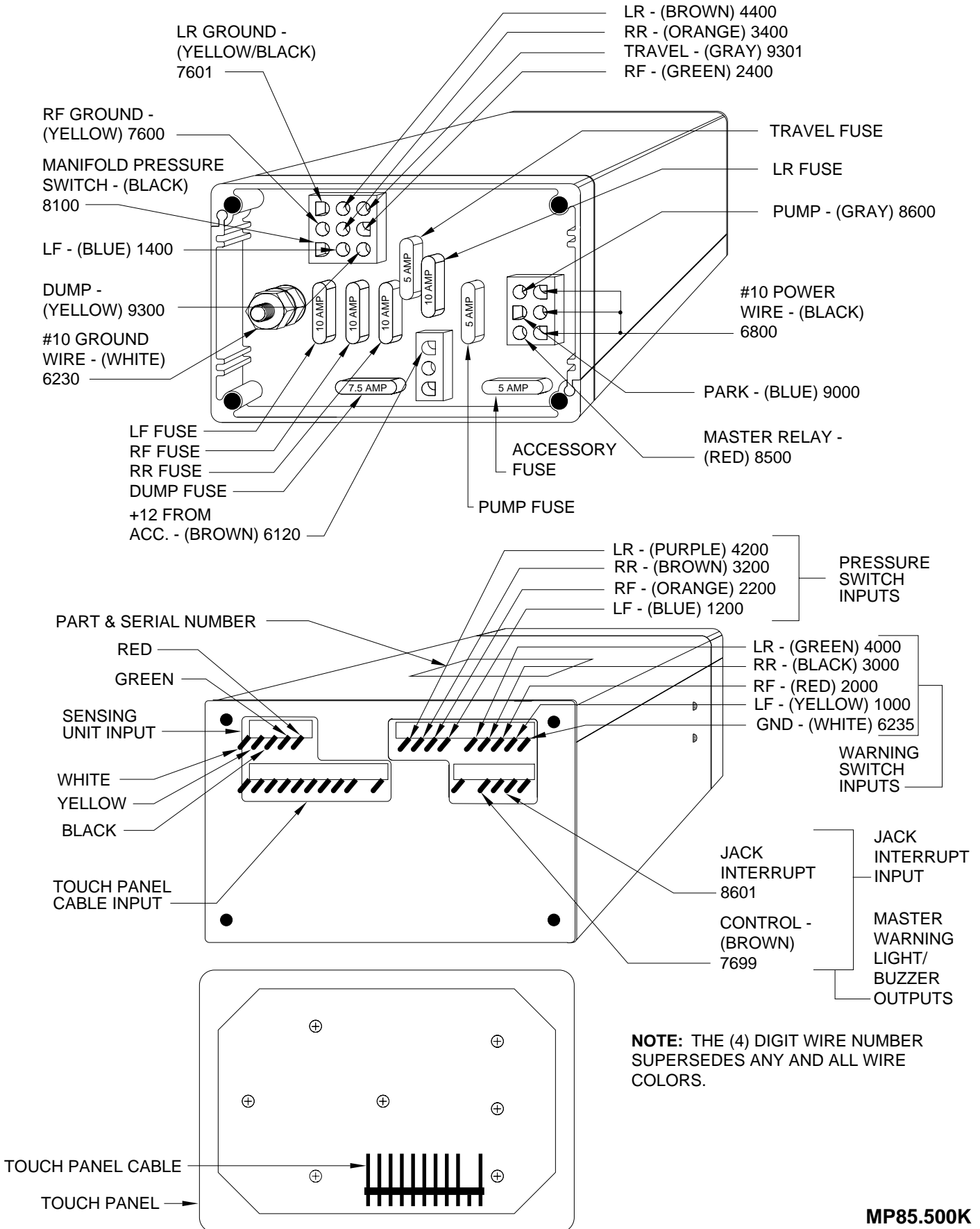



**ELECTRICAL CONNECTION DIAGRAM**  
**AIR DUMP INTERFACE - PILOT DUMP**  
**610 OR 310 SERIES LEVELING SYSTEM**

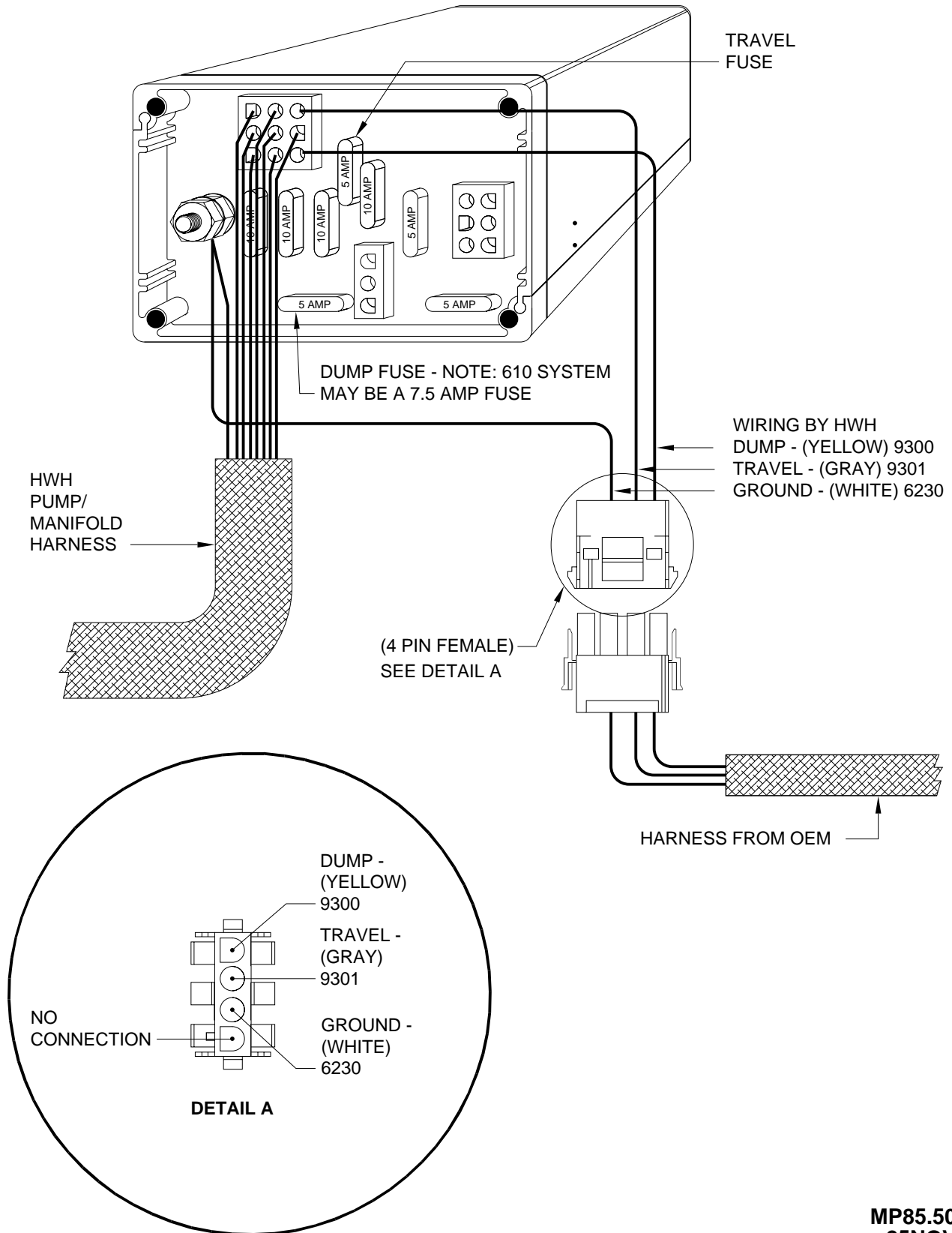

# ELECTRICAL CONNECTION DIAGRAM

## 610 SERIES LEVELING SYSTEM WITH TWO ROOM EXTENSIONS

### SOLENOID VALVES WITH VALVE RELEASE "T" HANDLES

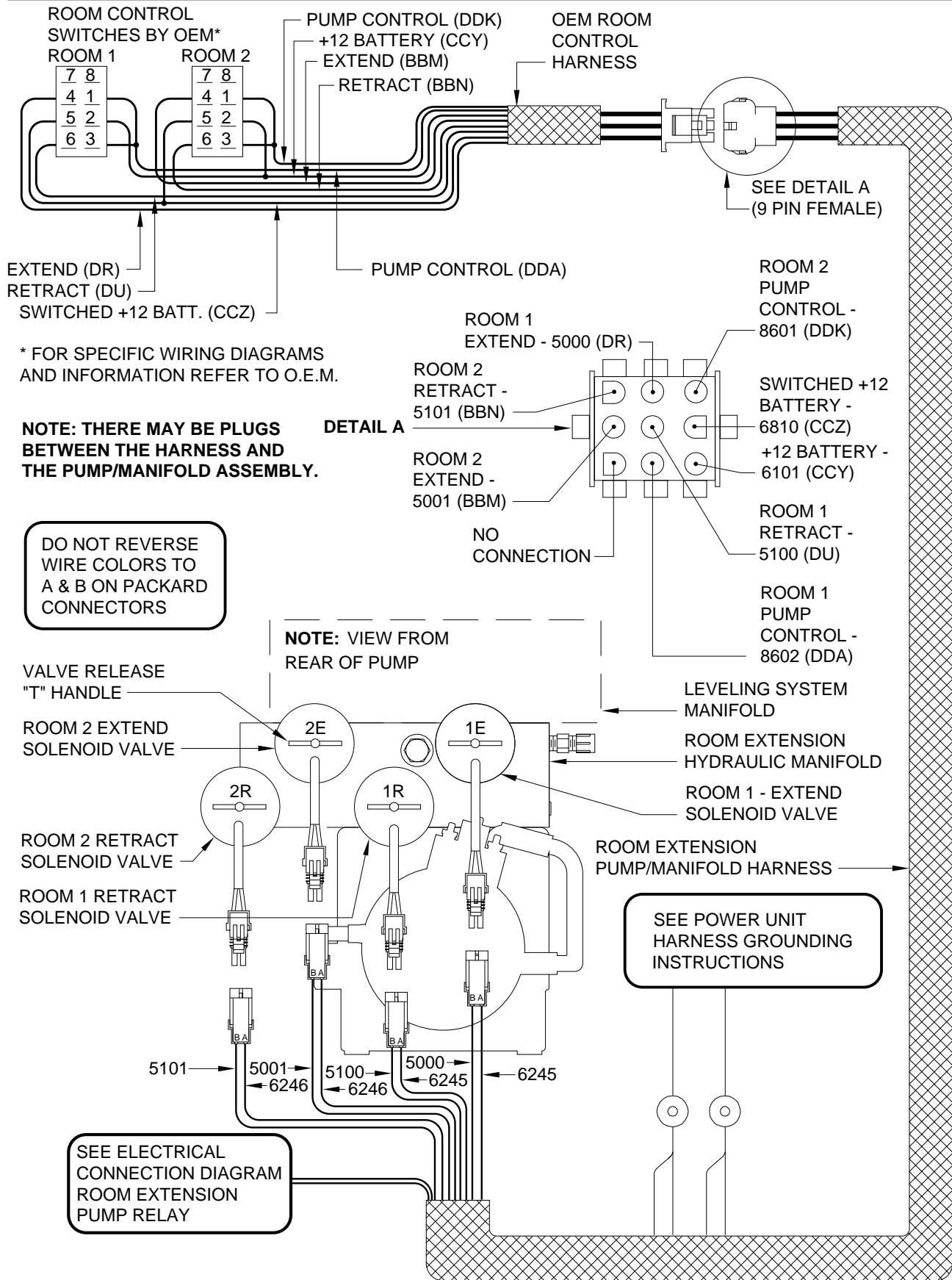

VIEW FROM PUMP END

# ELECTRICAL CONNECTION DIAGRAM

## 610 SERIES LEVELING SYSTEM WITH TWO ROOM EXTENSIONS

### SOLENOID VALVES WITH VALVE RELEASE NUTS

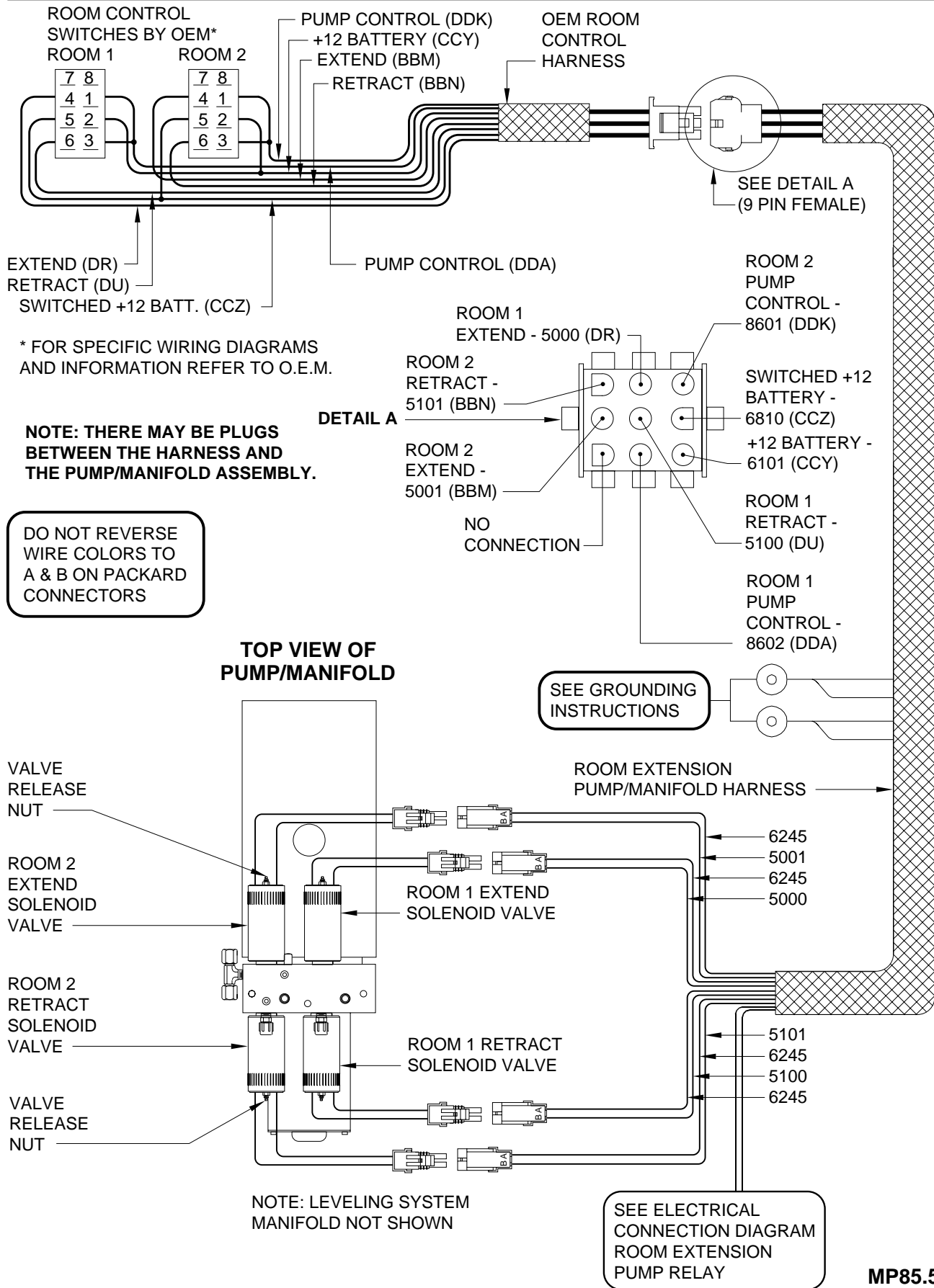

# ELECTRICAL CONNECTION DIAGRAM

## 610 SERIES LEVELING SYSTEM WITH TWO ROOM EXTENSIONS

### MASTER AND PUMP RELAY

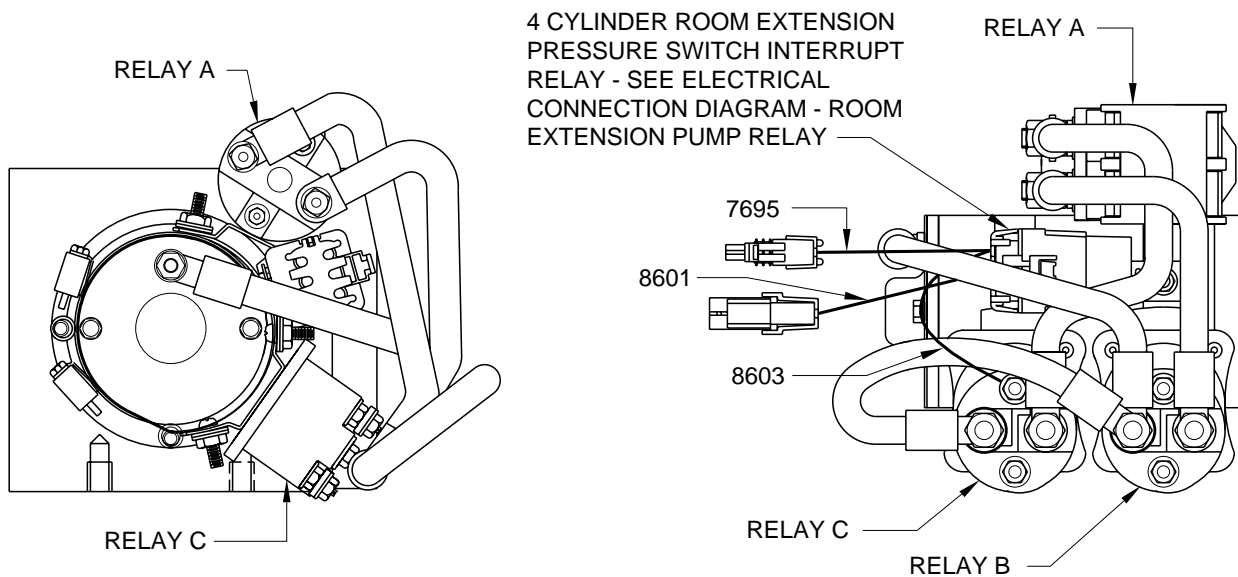
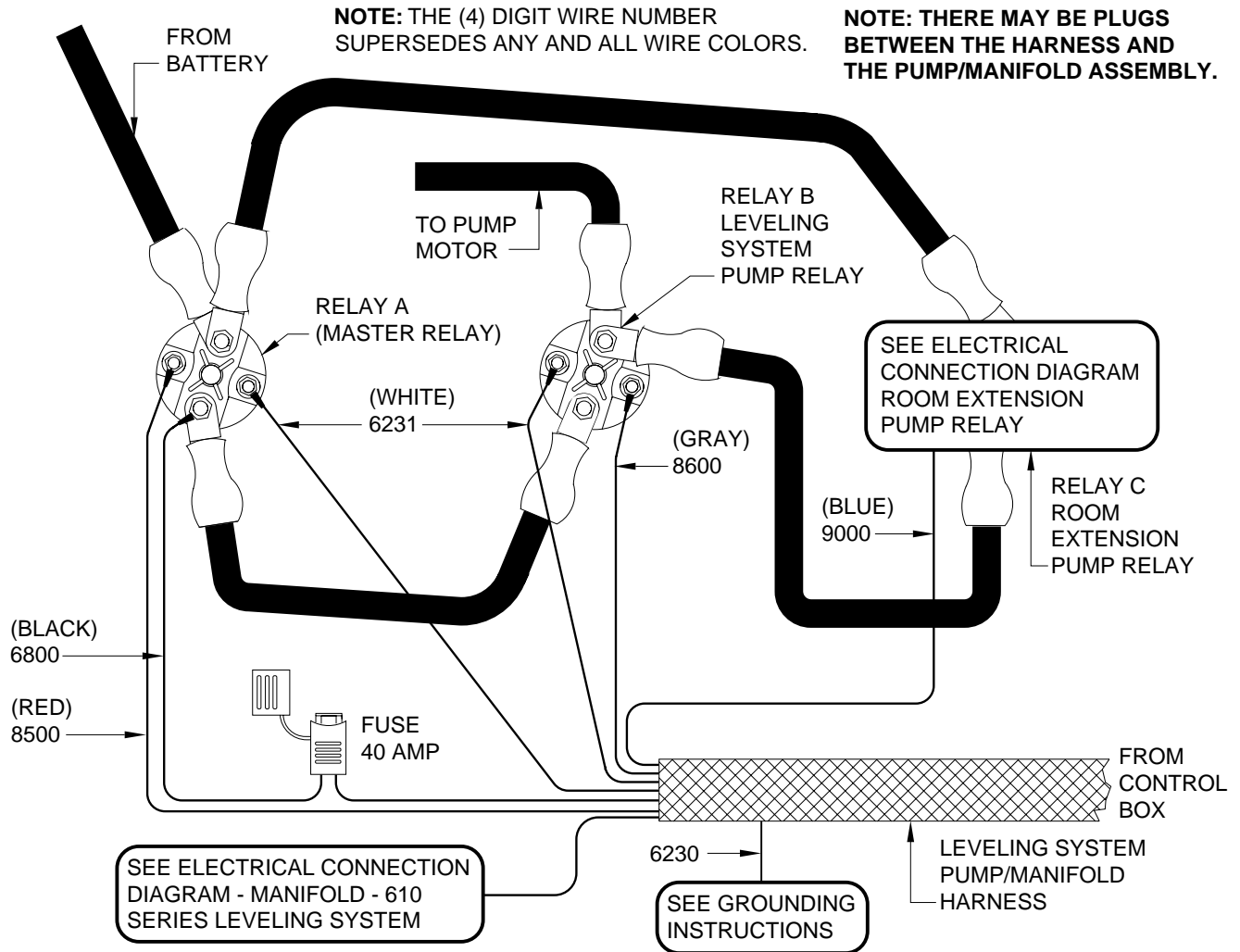

# ELECTRICAL CONNECTION DIAGRAM

## ROOM EXTENSION PUMP RELAY

### TWO ROOM EXTENSIONS

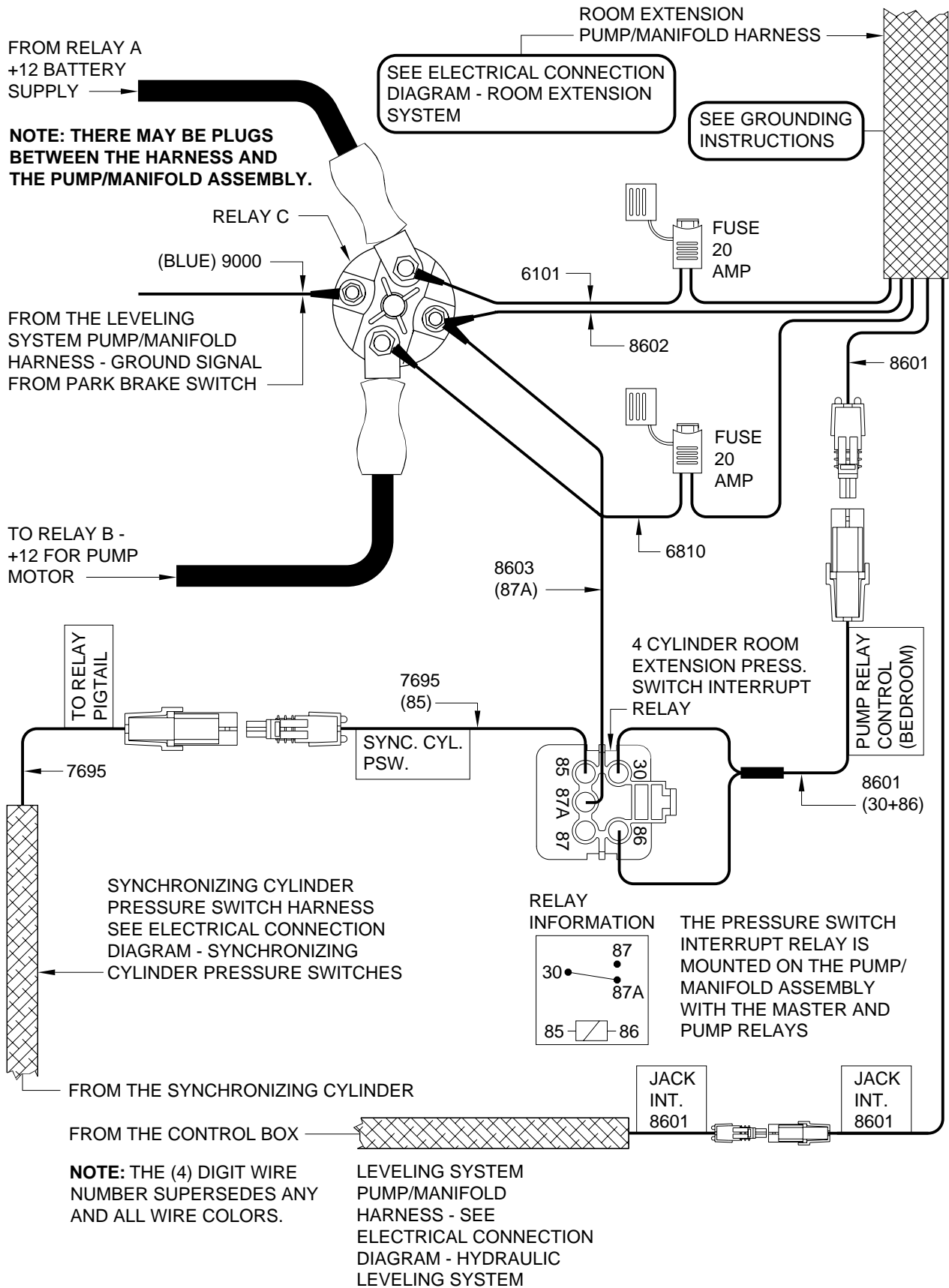

# ELECTRICAL CONNECTION DIAGRAM

## 610 SERIES LEVELING SYSTEM WITH TWO ROOM EXTENSIONS

### POWER UNIT/MANIFOLD PIGTAIL ASSEMBLY

COACHES BEFORE MID - YEAR 2000 DID NOT HAVE THE PIGTAIL ASSEMBLY. REFER TO THE DIAGRAMS IN THIS MANUAL FOR CORRECT INFORMATION. COACHES BUILT AFTER MID - YEAR 2000 MAY HAVE THE PIGTAIL ASSEMBLY. COMPONENT CONNECTIONS WILL REMAIN THE SAME. THIS PAGE SHOWS THE PLUG CONNECTIONS FOR THE MAIN HARNESSSES.

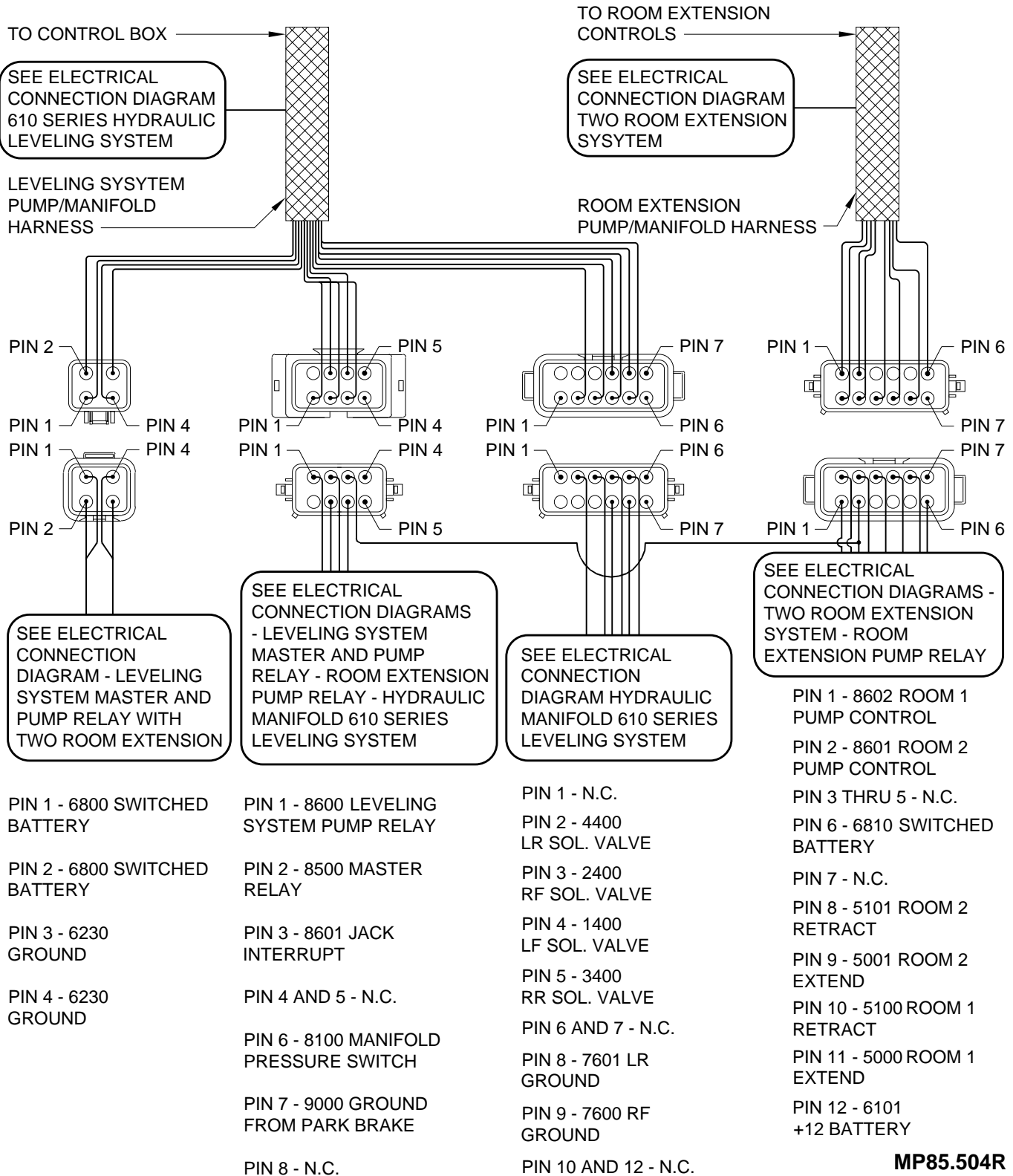

# ELECTRICAL CONNECTION DIAGRAM

## 610 SERIES LEVELING SYSTEM WITH ROOM EXTENSIONS

### POWER HARNESS AND MASTER WARNING INDICATORS

**NOTE:** THE (4) DIGIT WIRE NUMBER SUPERSEDES ANY AND ALL WIRE COLORS.

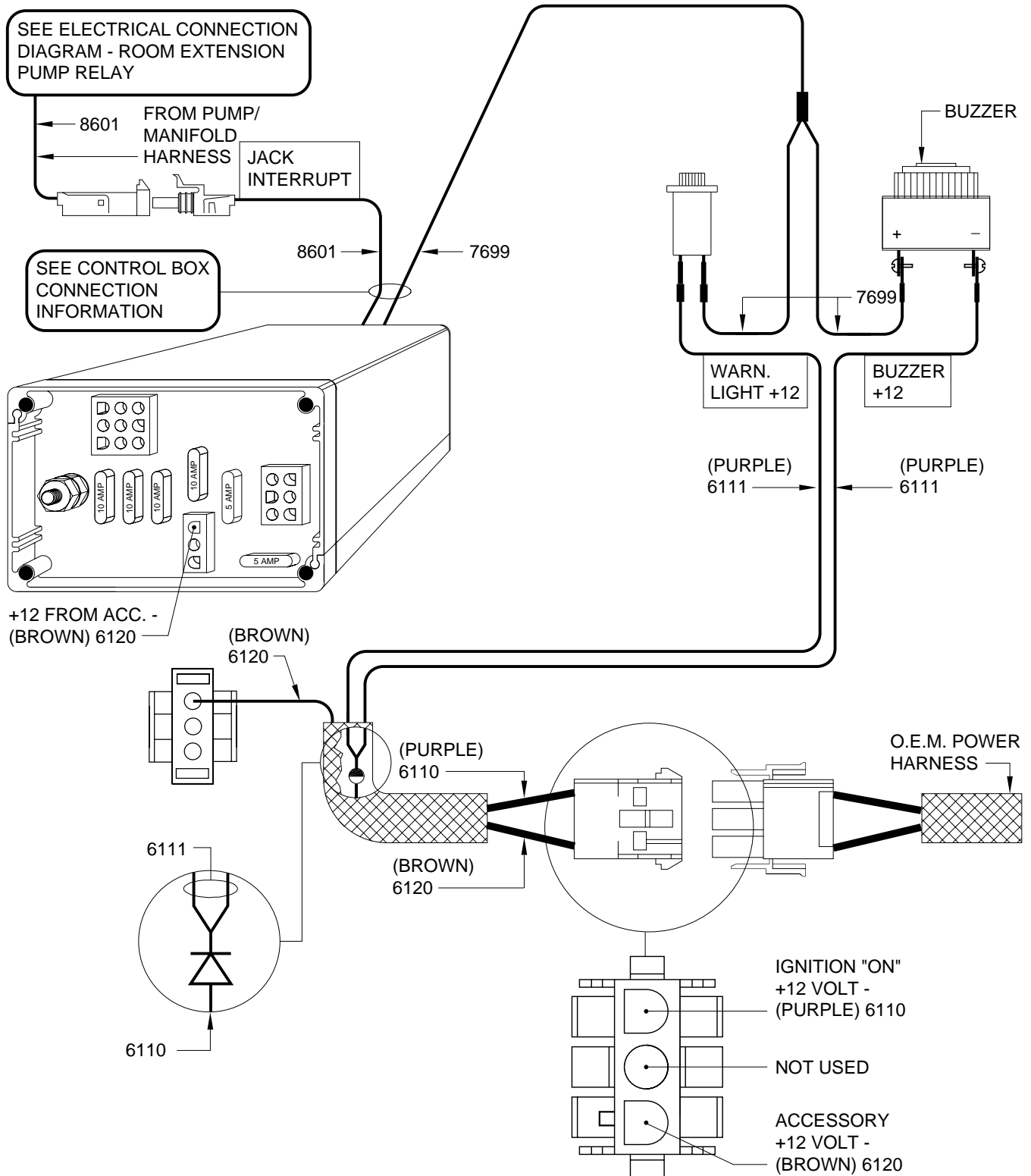

# ELECTRICAL CONNECTION DIAGRAM ROOM EXTENSION SYNCHRONIZING CYLINDER PRESSURE SWITCHES

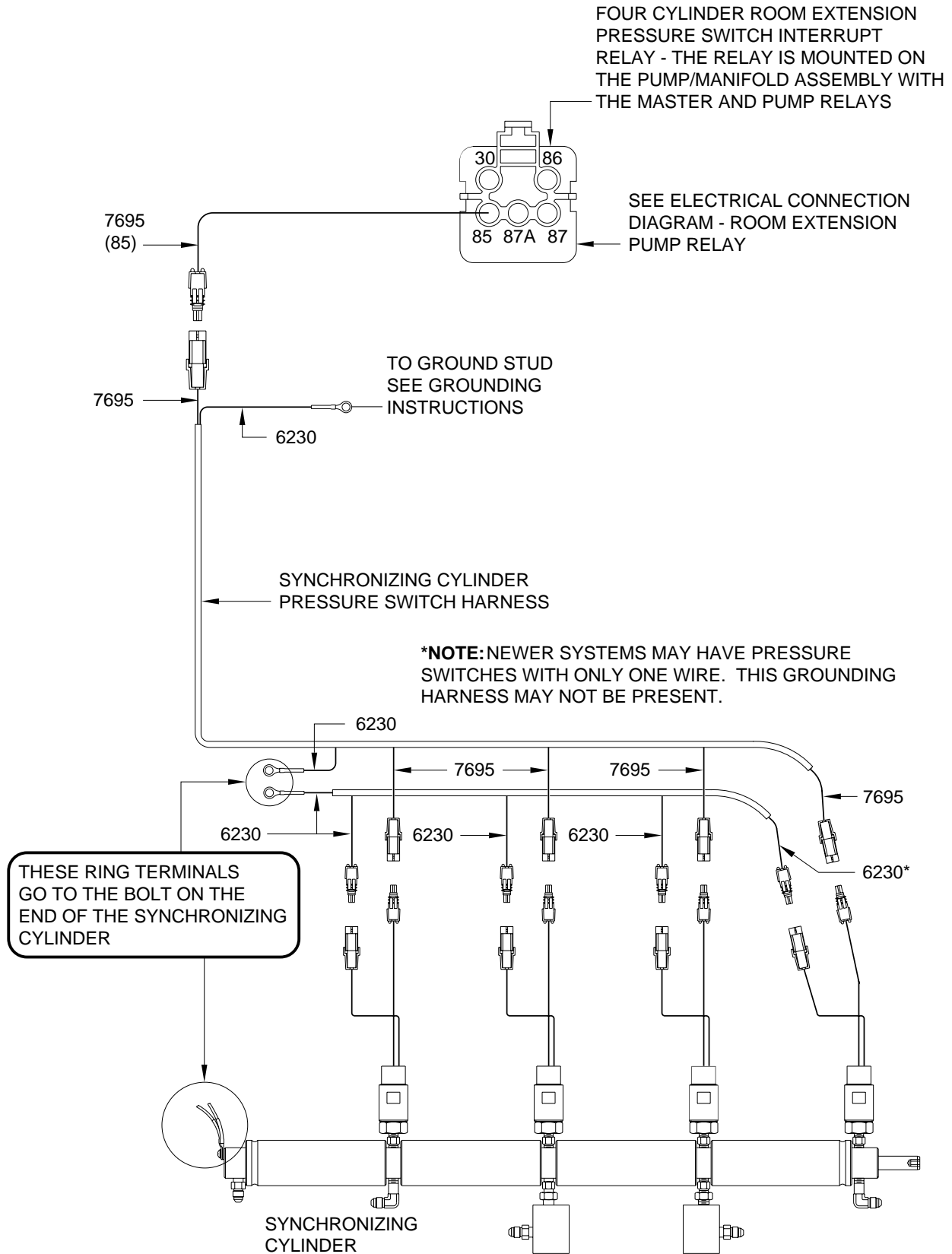



# GROUNDING INSTRUCTIONS 610 SERIES LEVELING SYSTEM WITH ROOM EXTENSION

## WELDED PUMP MOUNT

USING GROUNDING STUD AND 3/8" EXTERNAL STAR LOCKWASHERS AS SHOWN.

**IMPORTANT:** STAR LOCKWASHERS MUST BE USED BETWEEN GROUNDING SURFACE AND WIRE TERMINALS.

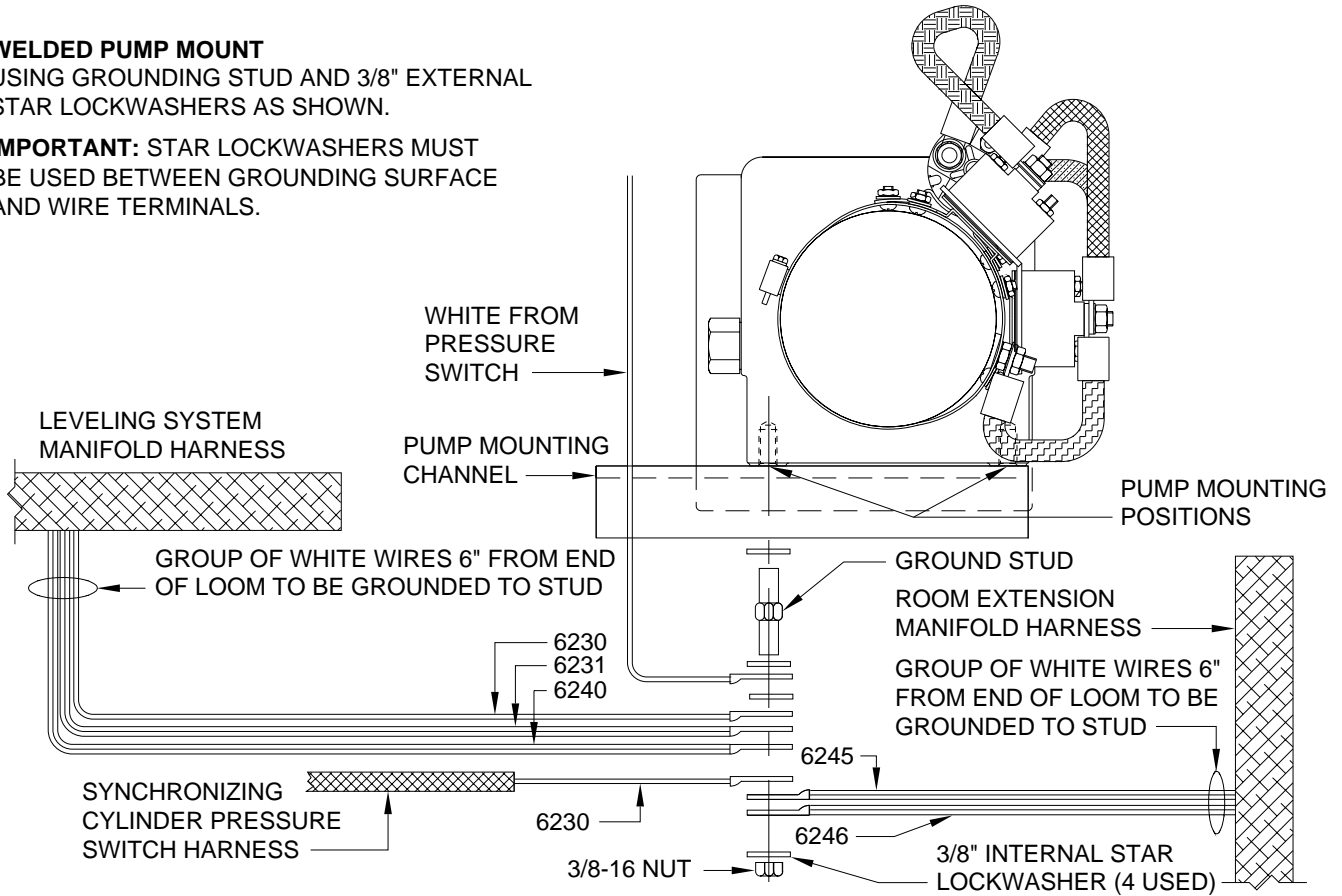

## PUMP MOUNTED REMOTE FROM FRAME

USE GROUNDING STUD AND 3/8" EXTERNAL STAR LOCKWASHERS AS SHOWN.

**IMPORTANT:** STAR LOCK WASHERS MUST BE USED BETWEEN GROUNDING SURFACE AND WIRE TERMINALS.

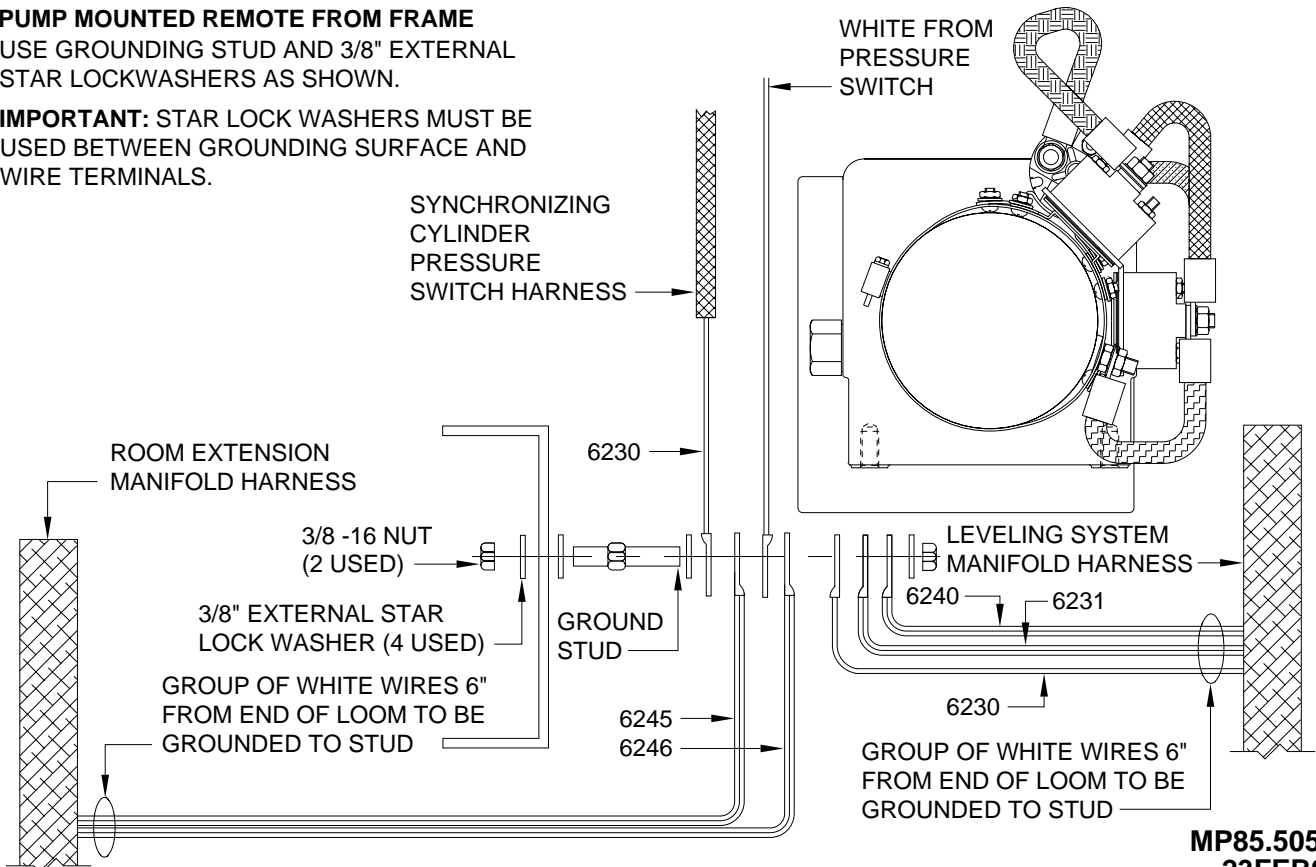



## BREATHER CAP - DIPSTICK - 1/4" NUT DRIVER

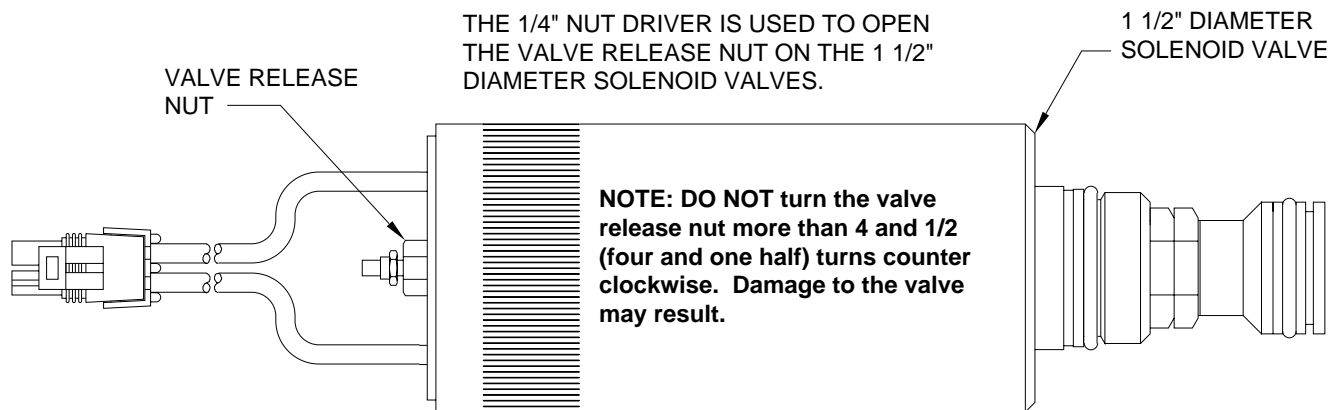

NOTE: THE BREATHER CAP IS LOCATED ON THE TOP SIDE OF THE POWER UNIT RESERVOIR.

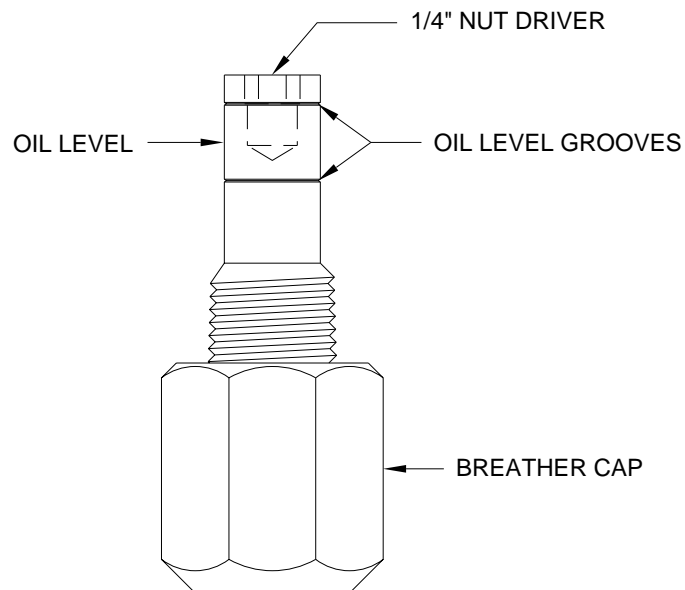

**IMPORTANT: PRIOR TO REMOVING THE BREATHER CAP, EITHER TO CHECK THE OIL LEVEL OR TO USE THE 1/4" NUT DRIVER, CLEAN ANY DEBRIS FROM THE TOP OF THE RESERVOIR. BEFORE RETURNING THE BREATHER CAP TO THE RESERVOIR, REMOVE ANY PAINT CHIPS OR OTHER DEBRIS FROM THE DIPSTICK INCLUDING DEBRIS INSIDE THE 1/4" NUT DRIVER.**