



SERVICE MANUAL

HWH® COMPUTER-CONTROLLED 2000 SERIES AIR LEVELING SYSTEM

FEATURING:

*Touch Panel Leveling Control
BI-AXIS® Air Leveling
(With or Without Tag Axle)*

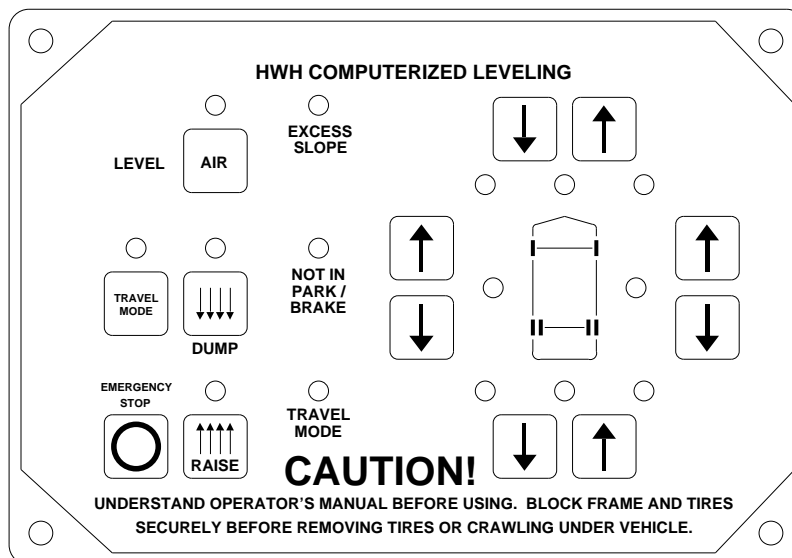

HWH CORPORATION

(On I-80, Exit 267 South)

2096 Moscow Road | Moscow, Iowa 52760

Ph: 800/321-3494 (or) 563/724-3396 | Fax: 563/724-3408

www.hwh.com

SECTION 1

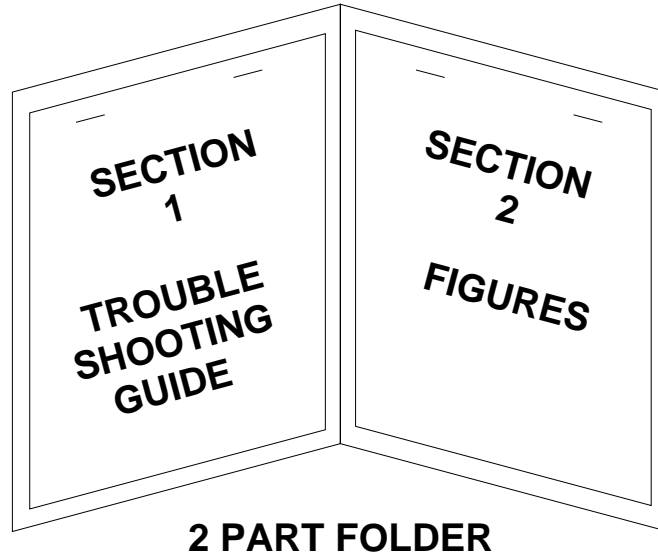

HOW TO USE MANUAL

This manual is written in two sections. Section 1 is the Trouble Shooting Guide. Section 2 is the figures. Begin diagnosis of the system with Section 1, the Trouble Shooting Guide. The Trouble Shooting Guide describes system operation with each phase of operation followed by symptoms of possible problems. The problem section is broken into 3 columns, Problem, Solutions and Figures. Under Problems, find the symptom you have encountered. The testing and repair for that problem is in the Solution (center) column. Diagrams for a particular Problem and Solution are in the Figures (right hand) column. This column will direct you to the proper figure in Section 2, Figures, for a more detailed view.

Before beginning your repair, it is **IMPORTANT** to read the **CAUTIONS** and **NOTES AND CHECKS** in the first section, **TROUBLE SHOOTING GUIDE**. In many cases this will save time and mistakes when trouble shooting a system.

This Repair Manual is offered as a guide only. It is impossible to anticipate every problem or combination of problems. For any problems encountered that are not addressed in this manual, contact HWH Corporation for assistance. (800-321-3494)

PROCEED WITH TROUBLE SHOOTING GUIDE



TROUBLE SHOOTING

CAUTIONS!

BLOCK FRAME AND TIRES SECURELY BEFORE CRAWLING UNDER VEHICLE. DO NOT USE AIR SUSPENSION TO SUPPORT VEHICLE WHILE UNDER VEHICLE OR CHANGING TIRES. VEHICLE MAY DROP AND OR MOVE FORWARD OR BACKWARD WITHOUT WARNING CAUSING INJURY OR DEATH.

DO NOT EXCEED 5 MPH OR TRAVEL LONG DISTANCES WHEN THE SUSPENSION IS NOT AT THE PROPER RIDE HEIGHT.

SAFETY GLASSES ARE TO BE WORN TO PROTECT EYES FROM DIRT, METAL CHIPS, OIL LEAKS, ETC. FOLLOW ALL OTHER SHOP SAFETY PRACTICES.

NOTES AND CHECKS

Read and check before proceeding with Trouble Shooting Steps.

NOTE: HWH CORPORATION ASSUMES NO LIABILITY FOR DAMAGES OR INJURIES RESULTING FROM THE INSTALLATION OR REPAIR OF THIS PRODUCT.

1. The trouble shooting guide must be followed in order. Problems checked for in one step are assumed correct and not checked again in following steps.
2. Batteries should be in good condition and fully charged. Low voltage can cause erratic operation.
3. Do not replace the control box unless the repair steps say to replace it. Otherwise the malfunctions may damage the new control box.
4. If the control box is removed, +12 ignition power must be applied to the travel solenoid wires (GRAY) 1700 in the front and (GRAY) 3700 in the rear air harnesses. This will allow the height control valve to function. See MP85.040C of section (2) Diagrams.

Important: Not all vehicle air suspensions are plumbed the same. Consult the vehicle manufacturer for specific plumbing diagrams.

Also, not all vehicles employ the speed switch to latch the "DUMP" or "RAISE" buttons in. These systems will have momentary "DUMP" and "RAISE" buttons.

This manual is intended for use by experienced mechanics with knowledge of air suspension and automotive electrical systems. People with little or no experience with HWH leveling systems should contact HWH technical service (800-321-3494) before beginning. Special attention should be given to all cautions, wiring, and air diagrams.

Special note: When installing a new control box, make sure the box is properly grounded before applying power to the system.

Suggested tools for trouble shooting the HWH leveling systems:

JUMPER WIRES(UP TO 10 GAUGE)
MULTI-METER
12 VOLT TEST LIGHT

PROCEED WITH THE TROUBLE SHOOTING STEPS ON THE FOLLOWING PAGE



CONTROL IDENTIFICATION

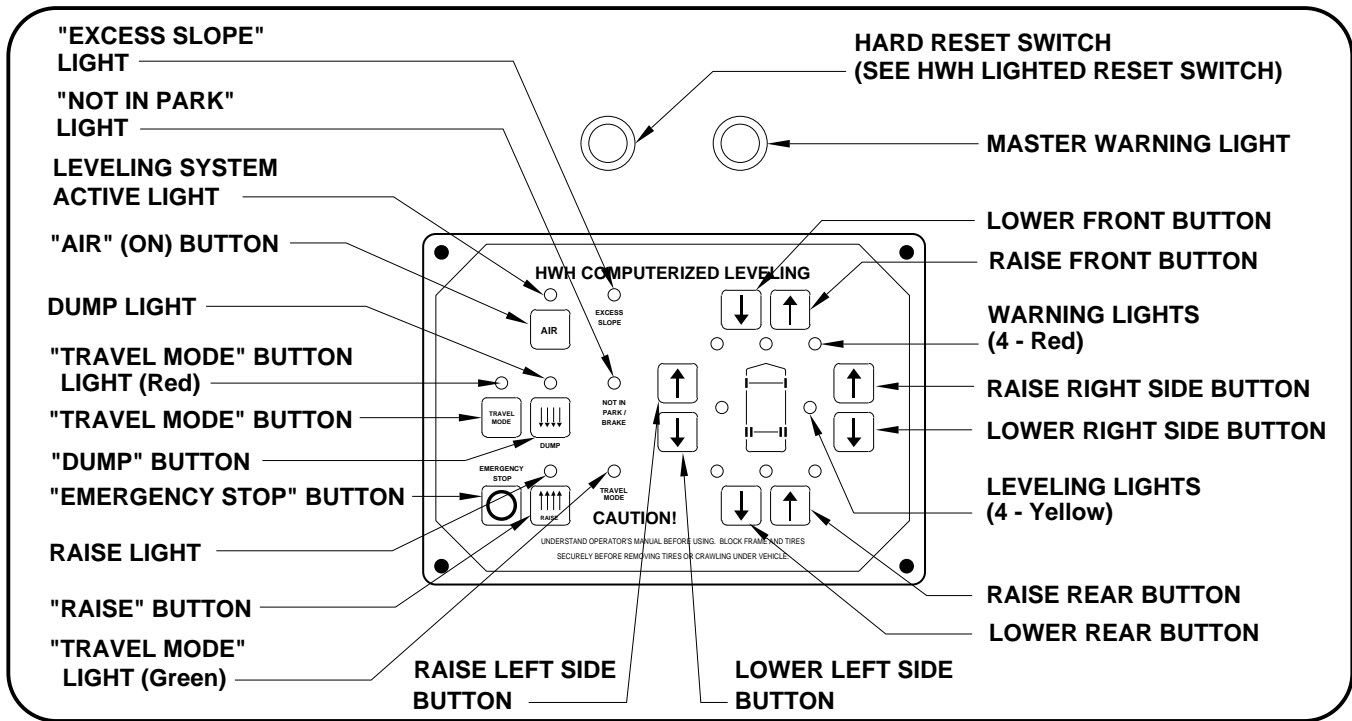

CONTROL FUNCTIONS

CONTROL BUTTONS

"AIR" BUTTON: This is the system active and automatic operation button. It works if the ignition is in the "ON" position.

"EMERGENCY STOP" BUTTON: This button turns the system OFF but does NOT control power to the "DUMP" or "RAISE" buttons. Pushing this button will NOT put the system in the TRAVEL mode.

"TRAVEL MODE" BUTTON: This button will put the Leveling System in the TRAVEL mode. The ignition must be "ON" for the vehicle to return to proper ride height for traveling.

"DUMP" BUTTON: This button will lower the whole coach by dumping air from the suspension system.

"RAISE" BUTTON: This button will raise the whole coach by adding air to the suspension system.

IMPORTANT: Read "DUMP AND RAISE FUNCTIONS" before using the "DUMP" or "RAISE" buttons.

UP ARROWS (RAISE BUTTONS): These momentary buttons are used for manually operating the air leveling systems. Sides or ends of the vehicle will raise while these buttons are pushed.

DOWN ARROWS (LOWER BUTTONS): These momentary buttons are used for manually operating the air leveling systems. Sides or ends of the vehicle will lower while these buttons are pushed.

INDICATOR LIGHTS

LEVEL SYSTEM ACTIVE LIGHT: ON when the system is active, and flashes during automatic leveling.

DUMP LIGHT: Flashes when "DUMP" button is pushed.

RAISE LIGHT: Flashes when "RAISE" button is pushed.

"EXCESS SLOPE" LIGHT: ON if the leveling system can NOT level the coach.

"TRAVEL MODE" BUTTON LIGHT (RED): Light flashes for 3 seconds after the "TRAVEL MODE" button is pushed.

"TRAVEL MODE" LIGHT (GREEN): ON if the ignition is in the "ON" position, the system is not being used, and there is sufficient air pressure in the suspension. See PREPARATION FOR TRAVEL.

WARNING LIGHTS: Function with the ignition in the "ON" position. ON when the LEVELING SYSTEM ACTIVE LIGHT is ON. See PREPARATION FOR TRAVEL.

LEVELING LIGHTS: One or two yellow lights can be on indicating the side, end or corner of the coach is low.

"NOT IN PARK/BRAKE" LIGHT: ON while the "AIR" button is being pushed if the Park Brake is NOT set. The light will go out when the "AIR" button is released.

MASTER WARNING LIGHT: ON any time the "TRAVEL" light is not ON, if the ignition is in the "ON" position.

TROUBLE SHOOTING

TROUBLE SHOOTING BASICS

Please read before continuing.

When trouble shooting the 2000 series leveling system, it is best to run the system in the manual mode to check individual functions before operating the system in the automatic mode.

Start the engine and push the "TRAVEL" button. Let air pressure build and allow the vehicle to return to travel height. If the vehicle is equipped with a tag axle, make sure the TAG DUMP switch is in the normal travel position. This will make the following procedures easier to perform. If the vehicle will not return to ride height see step 1c.

When trouble shooting raise, lower or travel mode problems, do not watch the vehicle. Watch the air bags. Make sure air bags will deflate completely when dumping or re-inflate when raising. Check all four sets of up and down arrows. Do a lower then raise check for one set of arrows at a time. It is important to do only one set of arrows at a time to avoid twisting unless this manual calls for a specific operating procedure.

Each air manifold is equipped with two 20 P.S.I. pressure switches. The contacts in these switches will close if the air pressure in the corresponding bag(s) is 20 P.S.I. or less. These switches are used as low air warning devices and also protect the vehicle from twisting while air is being dumped during manual or automatic leveling. Any time either front pressure switch is on, a manual or automatic front lower procedure will cease. Any time either rear (drive axle) pressure switch is on, a manual or automatic rear lower procedure will cease. Side lower procedures, either manual or automatic will not be affected by low air pressure in any air bag(s).

If the vehicle is equipped with a tag axle, there will be an air manifold for the tag axle also. The two pressure switches on

the tag manifold are used as low air warning devices only and will not affect any leveling procedures.

The drive axle manifold has a pressure switch that monitors the air pressure in the suspension system. This switch is also used only as a low air warning device.

If the vehicle is on a reasonably flat surface, unplug the pressure switch connector (CN100) at the control box. This will allow the air bags to deflate completely when using down arrows in the manual mode.

IMPORTANT: Do not run the system in the automatic mode with the pressure switches unplugged. Be careful to not twist the vehicle when manually operating the down arrows.

The control box is equipped with LED's to indicate inputs and outputs. Lit LEDs are not used to indicate a problem. Refer to the ELECTRICAL CONNECTION DIAGRAM - LED - FUSE LOCATION AND DESCRIPTION for LED functions.

IMPORTANT: Unplug the power connectors, CN98 and CN11, before separating the rings at the control box to check fuses or perform tests. This eliminates the possibility of shorting interior components of the control box.

In the following repair guide, each "Part" describes an operation or function of the leveling system. Below each "Part" there are three columns. The left hand column describes a possible symptom. The center column gives a diagnostic procedure and solution. The right hand column shows a diagram or refers to a diagram in the diagram section.

It is important to remember it is possible to encounter a problem not listed in this guide. If this occurs, contact HWH Corporation Customer Service for assistance.

Part 1. With the engine running, push the "TRAVEL MODE" button. The RED "TRAVEL MODE" button light should flash a few times. The vehicle should return to travel height. The GREEN "TRAVEL MODE" light should be on.

PROBLEM	SOLUTION	DIAGRAM
<p>1a. The (red) "TRAVEL MODE" button light will not flash. The HWH reset switch light is on.</p>	<p>Push the reset switch. If the reset light comes back on or comes back on after pushing the "TRAVEL MODE" button, replace the control box. CAUTION: The vehicle will return to travel height if the reset switch light is on and the ignition is in the "ON" position.</p>	

TROUBLE SHOOTING

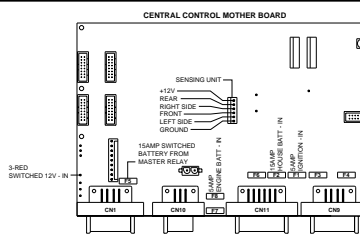
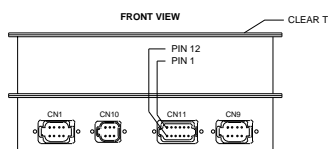
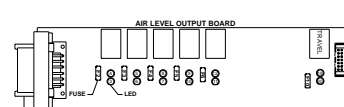
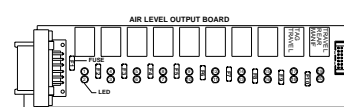
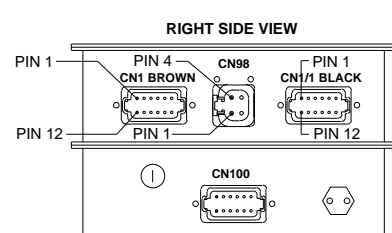
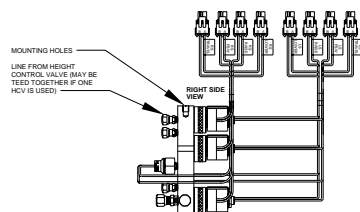
PROBLEM	SOLUTION	DIAGRAM
<p>1b. The (red) "TRAVEL MODE" button light will not flash, the HWH reset switch light is not lit.</p>	<p>LED #3 on the central control module should be lit. If LED #3 is lit, replace the touch panel. If LED #3 is not lit, check fuse F5 on the Central Control Module. If F5 is blown, there is a problem with the touch panel or the touch panel cables. If F5 is not blown, check fuses F1, F2, F6 (or F8) on the Central Control Module. If F1, F2, F6 (or F8) are blown the problem is most likely the control box. If F1, F2, F6 (or F8) are OK, check that there is +12 volts power on pins 1,6 and 12 of CN11 gray connector. If power is present on all pins, replace the box. If power is not present on a pin, trace that wire to it's source and repair.</p>	<div style="text-align: center;">  <p>REFER TO MP85.050V</p>  <p>REFER TO MP85.030C</p> </div>
<p>1c. The (red) "TRAVEL MODE" button light flashes, the vehicle will not return to ride height.</p>	<p>Check LED's 19 (YELLOW) and 20 (RED) on both air level output boards. If the vehicle is equipped with a tag axle, check LED's 17 (YELLOW) AND 18 (RED) on the rear output board. The (YELLOW) LED's should NOT be lit. The (RED) LED's should be lit. If any (YELLOW) Travel LED is lit replace the control box. If any (RED) Travel LED is not lit, check fuse F10 for that board. If LED 18 (RED) for Tag Axle is not lit check fuse 9. If the fuse is OK, replace the box. If the fuse is blown, there is a short in the harness or one of the travel valves on that fuse. If all (RED) Travel LED's are lit, check for +12 volts power on pin 8 of the 12 pin CN1 brown connector and pins 7 and 8 of the 12 pin CN1 black connector. Pin 7 is for Tag Axle Travel. Check for ground on pin 11 of these connectors. The harness can be unplugged to check these pins. If there is a problem with any of these pins, replace the control box. (If there is no ground on a ground pin, make sure there is a good ground on the two white wires in the 4 pin CN98 connector). If the proper pins have power and ground, the problem is the harness, harness connectors or the travel valves. Check for +12 volts power and ground at the travel valves. If power and ground is present, the travel valve may be bad. This can be checked by removing an air line from the height control valve at the HWH manifold. Air should flow through the manifold when the travel valve is open. Turn the ignition off. Make sure there is air in the bags. If necessary use the appropriate manual raise, up arrow, button to inflate the air bags. Remove the air line from the height control valve at the HWH manifold. Turn the ignition on and push the "TRAVEL MODE" button. The air bags should deflate. If they do, the travel valve is OK. If the bags do not deflate, replace the travel valve. If the travel valve is OK, the problem is in the suspension or height control valve. Refer to the vehicle manufacturer for assistance.</p> <p>CAUTION: The vehicle will drop quickly when an air line is removed. The vehicle frame must be supported properly before crawling under the vehicle or removing any air lines.</p>	<div style="text-align: center;">  <p>REFER TO MP85.060V</p>  <p>REFER TO MP85.080V</p>  <p>REFER TO MP85.040C</p>  <p>REFER TO MP75.030C</p> <p>SEE ALSO MP75.040C SEE ALSO MP75.050C</p> </div>

TROUBLE SHOOTING

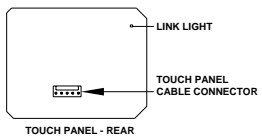
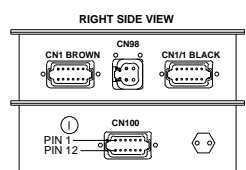
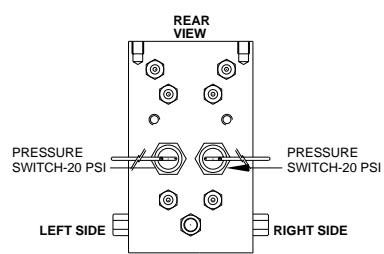
PROBLEM	SOLUTION	DIAGRAM
<p>1d. The (green) "TRAVEL MODE" light will not come on or comes on and goes out 1 minute later, the vehicle is at ride height and all air bags are inflated.</p> <p>If there is low air pressure in an air bag or a faulty air bag pressure switch, the "TRAVEL MODE" light will come on but go out approx. 1 minute later.</p> <p>NOTE: Either the (green) "TRAVEL MODE" light should be on or the MASTER WARNING light should be on any time the ignition key is in the "ON" position.</p>	<p>If the MASTER WARNING light is off and the (green) "TRAVEL MODE" light is off, remove the touch panel. If the link light is not blinking, there is a problem with the touch panel cable or the control box. If the link light is blinking, replace the control box. If the MASTER WARNING light is on and the (green) "TRAVEL MODE" light is off, unplug the CN100 connector from the control box. If the (green) "TRAVEL MODE" light remains off, replace the control box. If the (green) "TRAVEL MODE" light comes on, an air pressure switch on one of the air manifolds is on or an air pressure switch wire may be shorted to ground. The air bag pressure switch will come on if an air bag has less than 20 p.s.i. The system air pressure switch will come on if the system pressure is below 85 p.s.i. Make sure there is ample air bag and system air pressure. There should be no continuity between pin 6 (pressure switch ground supply) and pins 2,3,4,5 and 8 (individual air pressure switches) of connector CN100. Also pins 9 and 10 if the vehicle is equipped with a tag axle. Unplug any switch that has continuity to pin 6. Check for continuity between the 2 pins in the switch plug. Replace any pressure switch that has continuity or fix the wire short.</p> <p>NOTE: If any air bag pressure switch is on, there is a one minute delay when the ignition is turned on before the "TRAVEL MODE" light will go out and the master warning light will come on.</p>	<p style="text-align: center;">DIAGRAM</p>  <p style="text-align: center;">TOUCH PANEL - REAR</p> <p style="text-align: center;">REFER TO MP85.030C</p>  <p style="text-align: center;">RIGHT SIDE VIEW</p> <p style="text-align: center;">REFER TO MP85.040C</p>  <p style="text-align: center;">REAR VIEW</p> <p style="text-align: center;">REFER TO MP75.030C</p> <p style="text-align: center;">SEE ALSO MP75.040C SEE ALSO MP75.050C</p>

Part 2. With the vehicle engine running push the "AIR" button one time. The Leveling System Active light should come on steady. The four red warning lights should come on. The "TRAVEL MODE" light should go out. One or two yellow level lights may be on (opposing lights should not be on). The master warning light should come on.

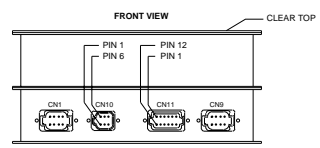
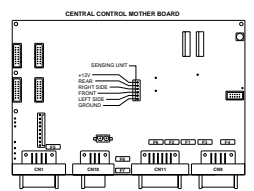
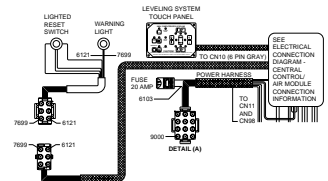
PROBLEM	SOLUTION	DIAGRAM
<p>2a. The System Active light will not come on.</p>	<p>Make sure there is power and ground to the control box in the 12 pin gray connector CN11. There is a link light on the back of the touch panel. This light should be flashing whenever the ignition is on. If the link light is not blinking, replace the control box. If the link light is blinking, replace the touch panel.</p>	<p style="text-align: center;">DIAGRAM</p>  <p style="text-align: center;">FRONT VIEW</p> <p style="text-align: center;">REFER TO MP85.030C</p>
<p>2b. The "NOT IN PARK/BRAKE" light comes on while the "AIR" button is being pushed.</p>	<p>There should be a ground on the number 11 pin of connector CN11 at the control box. With CN11 plugged in there should be a minimum of 7.5 volts between pin 1 and pin 11 of CN11. If a ground is present, replace the control box. If there is no ground, the problem is the 9000 wire or the park brake switch.</p>	 <p style="text-align: center;">CENTRAL CONTROL MOTHER BOARD</p> <p style="text-align: center;">REFER TO MP85.050V</p>
<p>2c. More than 2 yellow lights are lit or opposing yellow lights are lit.</p>	<p>The sensing unit is inside the control box. Unplug the sensing unit. Use a test light to apply a ground to pins 2,3,4 and 5. The appropriate yellow light should come on when it's pin is grounded. If the yellow lights do not work properly, replace the control box. If the yellow light work correctly, replace the sensing unit.</p>	 <p style="text-align: center;">LEVELING SYSTEM TOUCH PANEL</p> <p style="text-align: center;">REFER TO MP85.010C</p>
<p>2d. The Master Warning light does not come on.</p>	<p>Check for +12 volts power on pin 4 of connector CN10. Check for a ground on pin 6 of connector CN10. If +12 power or ground is present the problem is with wire 6121 (+12V), wire 7699 (GROUND) or the light itself. If +12 power or ground is not present, the problem is the Control Box.</p>	<p style="text-align: center;">REFER TO MP85.010C</p>

TROUBLE SHOOTING

Part 3. Unplug CN100, see page MP85.040C. Be careful to not twist the frame of the vehicle while operating the leveling system manually. **Only operate one set of LOWER then RAISE buttons at a time.**

Push a LOWER (Down Arrow) button. Hold until all of the air is exhausted from the air bags. Check that the appropriate air bags are completely deflated. Push the corresponding RAISE (Up Arrow) button. Check that the appropriate air bags have inflated raising the vehicle. Repeat this process for the other three sets of LOWER and RAISE buttons. When pushing a manual button, it will always operate two corners of the vehicle at the same time, both front, both rear, right front and rear or left front and rear.

NOTE: FOR VEHICLES EQUIPPED WITH A TAG AXLE. The tag axle manifold valves work in conjunction with the drive axle manifold valves. The tag axle manifold raise valves, are tied together in the harness with the drive axle manifold raise valves. The tag axle manifold dump valves each have it's own relay on the output board in the control box. When pushing either side LOWER button, there will be three sets of yellow and red LED's. When pushing the rear LOWER button, there will be four sets of yellow and red LED's. When pushing the front LOWER button, there will be two sets of yellow and red LED's. When pushing any RAISE button, there will be four sets of yellow and red LED's. This includes a red and yellow LED for the auxiliary air compressor on each output board.

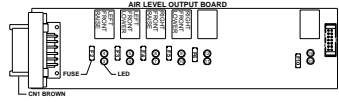
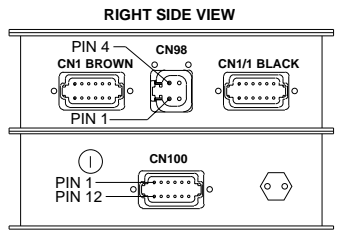
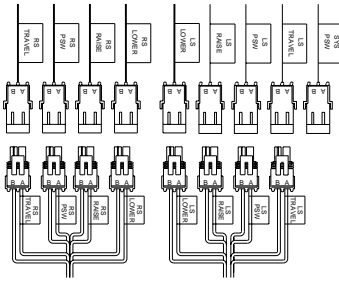
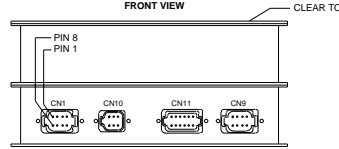
PROBLEM	SOLUTION	DIAGRAM
<p>3a. The air bags will not deflate when the LOWER (Down Arrow) button is pushed.</p> <p style="text-align: center;">OR</p> <p>The air bags will not inflate when the RAISE (Up Arrow) button is pushed.</p>	<p>Check the yellow and red LED's on the output boards for the solenoid valves that are being operated. Both LED's should be lit while a LOWER or RAISE button is being pushed. If a yellow LED is not lit, replace the control box. If no red LED's are lit, check for +12 power on pins 1 and 2 of CN98. If power is not present, trace the wires to their source or repair the wires. If power is present, check the fuses for these relays. If the fuses are OK, replace the control box. If the fuses are blown, the wires or solenoid valves are shorted.</p> <p>If not all the proper red LED's are lit, check the fuse for that relay. If the fuse is OK replace the control box. If the fuse is blown the wire or solenoid valve is shorted.</p> <p>If the proper yellow and red LED's are lit, check for +12 and ground at the solenoid valve on the manifold. If ground is not present, check for a ground on pin 11 in the black or brown CN1 connector at the control box if ground is not present, check for a ground on pins 3 and 4 of CN98. If ground is present replace the control box. If ground is not present, the problem is the 6231 (white) wires or their connection to the ground studs. If ground is present on pin 11 of the CN1 connectors, the problem is in the harness or harness plugs.</p> <p>If +12 is not present at the solenoid valve, the problem is the harness or the harness plugs.</p> <p>If +12 and ground is present at the solenoid valve the problem is the valve.</p> <p>NOTE: If using a DOWN button, check that the exhaust port at the manifold is not plugged. If using a RAISE button, make sure that there is good air pressure to the manifold.</p>	<div style="text-align: center;">  <p>REFER TO MP85.060V</p> <p>SEE ALSO MP85.080V</p> </div> <div style="text-align: center;"> <p>RIGHT SIDE VIEW</p>  <p>REFER TO MP85.040C</p> </div> <div style="text-align: center;">  <p>REFER TO MP75.030C</p> </div> <div style="text-align: center;"> <p>FRONT VIEW CLEAR TOP</p>  <p>REFER TO MP85.030C</p> </div>
<p>3b. The correct air bags will not deflate when a LOWER button is pushed.</p>	<p>The problem is either an air line connection or electrical connection that is not in the correct position. Check all air line connections, electrical connections and wire locations in plugs according to the proper diagrams.</p>	
<p>3c. The correct air bags will not inflate when a RAISE button is pushed.</p>	<p>Because the correct air bags deflate when the LOWER button is pushed, it can be assumed the air line plumbing is correct. Check the electrical connections and wire locations in plugs according to the proper diagrams.</p>	

TROUBLE SHOOTING

PRESSURE SWITCH TESTS

Part 4-1. Plug in the pressure switch connector, CN100. Make sure the vehicle is at ride height and all air bags have adequate air pressure. Push either side LOWER button until the air bags for that side are deflated. Push the front LOWER button. Nothing should happen. Push the rear LOWER button. Nothing should happen. Allow the vehicle to return to ride height and repeat the process with the other side LOWER button. If the vehicle is equipped with a tag axle, the tag axle lower solenoid valves will work with the drive axle valves. The tag axle pressure switches will not effect the lowering procedure.

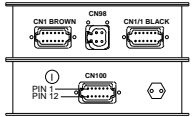
PROBLEM	SOLUTION	DIAGRAM
<p>4-1a. The air bags will deflate completely with CN100 plugged in when the front or rear LOWER button is pushed.</p>	<p>Make sure all air bags are completely deflated. Unplug CN100. Check at the harness connector for continuity between pin 6 (ground) and pins 2 (left front pressure switch), 3 (right front pressure switch), 4 (right rear pressure switch) and 5 (left rear pressure switch). If there is no continuity between pin 6 and another pin, there is a bad pressure switch or a problem with the wire or connection to that pressure switch. If there is continuity, the problem is the control box or the connection at CN100.</p>	<div style="text-align: center;">  </div> <p style="text-align: center; font-weight: bold;">REFER TO MP85.040C SEE ALSO MP75.030C SEE ALSO MP75.040C SEE ALSO MP75.050C</p>

Part 4-2. Make sure the vehicle is at ride height, all air bags have adequate air pressure and the pressure switch connector, CN100 is plugged in. Push the front LOWER button. Air should exhaust from the front air bags until a front pressure switch comes on. Repeat the process with the rear LOWER button. Air should exhaust from the rear air bags until a rear pressure switch comes on.

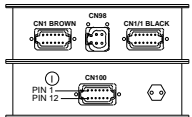
PROBLEM	SOLUTION	DIAGRAM
<p>4-1b. The air will not exhaust when the front or rear LOWER button is pushed.</p>	<p>Make sure an air bag is not deflated. Check at the harness connector for continuity between pin 6 (ground) and pin 2 (left front pressure switch), 3 (right front pressure switch), 4 (right rear pressure switch) and 5 (left rear pressure switch). If there is continuity between pin 6 and another pin, there is a bad pressure switch or a problem with the wires or connector for that pressure switch. If there is no continuity between pin 6 and another pin; the problem is the control box.</p>	<div style="text-align: center;">  </div> <p style="text-align: center; font-weight: bold;">REFER TO MP85.040C SEE ALSO MP75.030C SEE ALSO MP75.040C SEE ALSO MP75.050C</p>

Part 5. Any time a raise function is performed, there is a +12 volt signal to turn the HWH auxiliary air compressor on. Push any RAISE (UP ARROW) button to check the air compressor. Some compressors have a pressure switch which will not allow the compressor to run if the vehicle has adequate air pressure in the suspension. Check the air compressor with the engine off and the system air pressure below 90 p.s.i.

This manual shows a common compressor arrangement used. Other compressors may be used. Consult the owners manual or HWH Technical Service for specific diagrams.

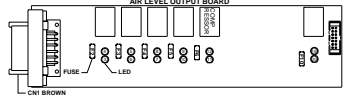
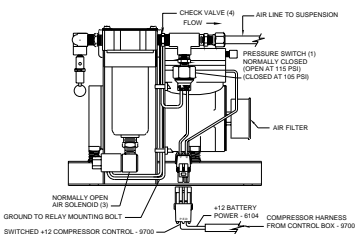
PROBLEM	SOLUTION	DIAGRAM
<p>5a. The compressor will not run when a RAISE button is pushed.</p>	<p>Check the yellow LED (12) and red LED (11) on the front air output board, both LEDs should be on. If the yellow LED is not lit, replace the control box. If the yellow LED is lit but the red LED is not, check fuse 6. If fuse 6 is OK, replace the control box. If fuse 6 is blown, there is a short on the 9700 wire or the relay on the compressor is bad.</p> <p>If both LED's are lit, check for +12 power on the 9700 wire at the compressor. If power is not present, there is a problem with the 9700 wire. If +12 power is present, check for +12 battery power on the 6104 wire at the compressor relay. Check the 15 amp fuse. The compressor and compressor relay are grounded through the compressor mounting bracket. Make sure the bracket has a good frame ground. If the 9700 wire goes to a pressure switch before the relay, make sure there is power through the pressure switch. If there is +12 battery power to the relay and +12 power and ground to the coil of the relay but no power through the relay, the relay is bad. If there is +12 power through the relay and a good ground for the compressor, the compressor is bad.</p>	<div style="text-align: center;">  </div> <p style="text-align: center; font-weight: bold;">REFER TO MP85.060V</p> <div style="text-align: center;">  </div> <p style="text-align: center; font-weight: bold;">REFER TO MP75.060C</p>

TROUBLE SHOOTING

Part 5. Continued. . .

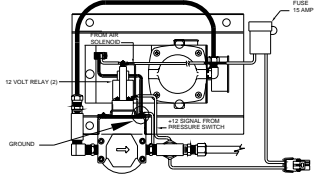
PROBLEM	SOLUTION	DIAGRAM
<p>5b. The compressor will not shut off.</p>	<p>Some compressors have auxiliary control which allows the compressor to run at times other than when leveling. Refer to the owners manual or HWH Technical Services for specific compressor wiring diagrams. Check LED's 11 and 12 on the front air output board. If the LED's are lit, and the leveling system is not in the automatic mode, replace the control box. If the LED's are not lit, the compressor relay is stuck and should be replaced.</p>	 <p style="text-align: center;">REFER TO MP75.060C</p>
<p>5c. The compressor will not build pressure.</p>	<p>There is a +12 volt normally open solenoid on the compressor water trap. Any time the compressor is turned on, this solenoid will close. Check for +12 and ground to the solenoid when the compressor is running. If either is not present, there is a problem with the wiring. If +12 and ground is present, replace the solenoid</p>	

Part 6. Sensing unit diagnostics. The sensing unit is mounted in the control box and must be working properly and be adjusted properly for the system to function in the automatic mode. Refer to MP45.271M for proper adjustment procedures.

A lit yellow level light indicates a side or end of the vehicle is low. When all yellow level lights are out, the vehicle should be level within the tolerances of the sensing unit, about 1 inch side to side and about 3 to 4 inches front to rear.

Use the manual buttons or move the vehicle to different locations to make sure each yellow level light will come on and can be made to go out.

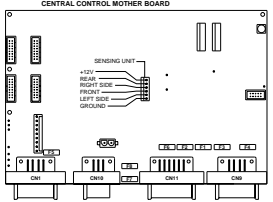
PROBLEM	SOLUTION	DIAGRAM
<p>6a. One or more yellow level lights will not come on</p> <p style="text-align: center;">OR</p> <p>One or more yellow level lights will not go out.</p>	<p>Unplug the sensing unit. Pin 1 supplies ground for the sensing unit. Pins 2,3,4 and 5 supply a ground from the sensing unit to turn the yellow lights on. Pin 6 supplies +12 power for the sensing unit. Use a test light to check pin 1 for ground and pin 6 for +12. Use the test light connected to ground to apply a ground to pins 2,3,4 and 5 one at a time. Ground one pin and one yellow light should come on. If any pin does not function correctly, replace the control box. If the pins function correctly replace the sensing unit.</p>	 <p style="text-align: center;">REFER TO MP85.050V</p>

Part 7 Tag Dump diagnostics. The tag dump switch is supplied by the vehicle manufacturer. Power for the tag dump switch is supplied +12 power by the HWH control box on wire 6801. The tag dump signal is wire number 7521. The tag dump switch will only work with the ignition on and the leveling system off. When the tag dump switch is in the DUMP position the tag axle manifold travel valves are turned off and the tag axle manifold lower valves are turned on.

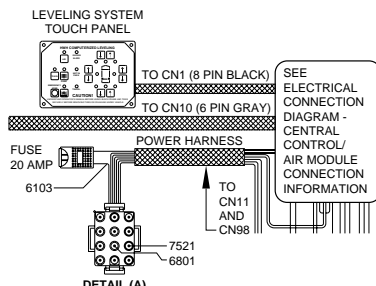
PROBLEM	SOLUTION	DIAGRAM
<p>7a. The tag axle will not dump.</p>	<p>With the engine running put the tag dump switch in the DUMP position. The red LED 18 for tag travel should be off. The yellow LED 17 should be on. The left tag lower yellow LED 14 and red LED 13 along with the right tag lower yellow LED 15 and red LED 16 should be on. If the LED's are correct there is a problem with the connections, wires or valves on the tag axle manifold. If the LED's are not correct, check for +12 on wire 7521, connector CN100, pin 11 at the control box. If +12 is present replace the control box. If +12 is not present, check for +12 on pin 7 of CN100. If +12 is not present, replace the control box. If +12 is present, the problem is wire 6801, the tag dump switch or wire 7521.</p>	 <p style="text-align: center;">REFER TO MP85.010C</p>

TROUBLE SHOOTING

Part 7. Continued. . .

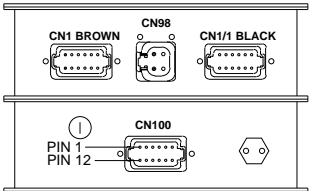
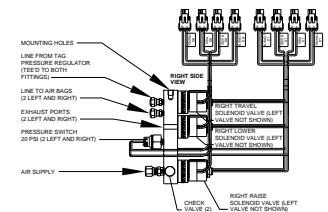
PROBLEM	SOLUTION	DIAGRAM
<p>7b. The tag axle will not lift.</p>	<p>Not all coaches will use the 3800 wire supplied by HWH for the Tag Lift.</p> <p>If the HWH 3800 wire is used, check that there is power on the 7521 wire, connector CN 100 pin 11. If there is no power on the 7521 wire refer to 7a. If there is power on the 7521 wire, check LED's 1 (YELLOW) and 2 (RED). If both are on, there should be power on the 3800 wire. If not, there is a problem with the connectors or wire. If there is power on the 3800 wire at the box, the problem is with the wire, connection to the Tag lift or the Tag lift.</p> <p>If LED 1 (YELLOW) is on and not LED 2 (RED), check fuse F1. If the fuse is good replace the box. If the fuse is blown, there may be a problem with the 3800 wire or the Tag lift. If LED 1 (YELLOW) is not on, replace the control box.</p>	<p>RIGHT SIDE VIEW</p>  <p>REFER TO MP85.040C</p>  <p>REFER TO MP75.050C</p>

AUTOMATIC LEVELING

Part 8. Automatic Leveling Procedures and Diagnostics. Push the "LEVEL" (AIR) button once to turn the panel on. Push the "LEVEL" button a second time. This will start the automatic leveling process. The system will attempt to level the vehicle by lowering the high side and/or end of the vehicle (opposite side/end of lit yellow level indicators). If a pair of "LOWER" valves are on continuously for 45 seconds, the system will attempt to finish leveling by raising the low side or end of the vehicle (lit yellow level indicators). Once the system is in the raise mode it will not try to lower the vehicle again in that leveling sequence. If the front or rear of the vehicle is being lowered, and a pressure switch for that end comes on indicating low air pressure, the system will stop lowering the vehicle and go immediately into raise mode. It will not wait for the 45 second timer.

When all yellow level indicators are out the "LEVELING SYSTEM ACTIVE LIGHT" will stop flashing and start pulsating dimly. The system is now in the sleep mode. There is no delay between the yellow lights going out and the SYSTEM ACTIVE light pulsating dimly. The ignition key can be turned off. The SYSTEM ACTIVE light will continue to pulsate for 10 minutes. At that time the panel will turn off but the system will remain in the SLEEP mode.

SLEEP MODE: After all yellow lights have gone out, the system may be turned off or left in the SLEEP MODE. In the SLEEP MODE the touch panel will be off but the processor will check the level sensing unit every half hour. If an input for a yellow level indicator is on continuously for 1 minute, the processor will wake up the system, turn the touch panel on and relevel the vehicle according to lit yellow indicators. The system will attempt to level the vehicle by first lowering, then raising the vehicle as necessary. When a level position is achieved the system will return to the SLEEP MODE with the touch panel turning off 10 minutes after leveling is achieved.

EXCESS SLOPE: During any leveling sequence, if a level position is not achieved, the EXCESS SLOPE light will come on. EXCESS SLOPE is when any pair of raise valves have been on continuously for 15 minutes. 10 minutes after the EXCESS SLOPE light comes on the panel will turn off if the ignition is off. Any time the ignition is turned on the EXCESS SLOPE light will come on until the "TRAVEL" button is pushed, the Park Brake is released if the ignition is on, or the vehicle is leveled using manual air leveling.

If the leveling system does not operate properly in the Automatic mode, recheck the system in the Manual mode starting with Part 1. If the system works properly in the Manual Mode, it should work in the Automatic mode. After rechecking the system, if it works manually but not automatically, contact HWH customer service for assistance.

MAINTENANCE/SERVICE

SENSING UNIT ADJUSTMENT

Level the vehicle by placing a bubble level in the center of the freezer floor or upon whichever surface within the vehicle that is to be level. Using the Leveling System and the bubble level, ignoring the yellow LEVEL lights on the Touch Panel, level the vehicle until the bubble is centered.

With the vehicle level according to the bubble level, if there are no yellow lights lit on the Touch Panel, the sensing unit is properly adjusted. If there are yellow LEVEL lights lit on the Touch Panel, manual adjustments to the Sensing Unit are needed. A 7/8", 3/4" or 5/16" socket w/driver or box end wrench and a philips screw driver will be needed.

The Sensing Unit is mounted inside the Control Box. The Control Box is mounted to the power unit/valve assembly.

There are four LED's on the Sensing Unit, A,B,C and D. Refer to the drawing below. The Sensing Unit is adjusted by turning the adjustment nut to turn out LED's B and D. The adjustment screw will turn out LED's A and C. If the adjustment nut has to be turned more than 1/2 flat or the adjustment screw has to be turned more than 3/4 turn to turn the LED out, there may be a problem with the Sensing Unit or the mounting of the Control Box. If two LED's are on, it is best to make the B-D adjustments first, then hold the adjustment nut from moving while making the A-C adjustment.

NOTE: If opposing LED's are lit, there is a problem with the Sensing Unit.

If LED (A) is lit: Turn the adjustment screw COUNTER CLOCKWISE until the LED is off.

If LED (C) is lit: Turn the adjustment screw CLOCKWISE until the LED is off.

If LED (B) is lit: Turn the adjustment nut COUNTER CLOCKWISE until the LED is off.

If LED (D) is lit: Turn the adjustment nut CLOCKWISE until the LED is off.

IMPORTANT: When all 4 LED's are off, move the vehicle to an unlevel position so one or two yellow lights are on. Level the vehicle according to the yellow LEVEL lights. Recheck the level. If more adjustment is needed, DO NOT try to adjust the sensing unit until the yellow level lights go out, instead just "tweak" the sensing unit, ignoring the LED's on the sensing unit.

Example: After the initial adjustment and releveling the vehicle, the front is still low. This means the front yellow level light is turning off too soon. Determine which sensing unit light is the front light, A-B-C or D. Move the adjustment for that light very, very, slightly in the OPPOSITE direction that is given in the above instructions for LED's A, B, C, and D. This will allow the front yellow light to stay on slightly longer to bring the front up more. Again, unlevel the vehicle then relevel the vehicle using the yellow level lights on the touch panel. Recheck with a level. Repeat the "tweaking" process until the system levels the vehicle properly.

TOP VIEW - SENSING UNIT

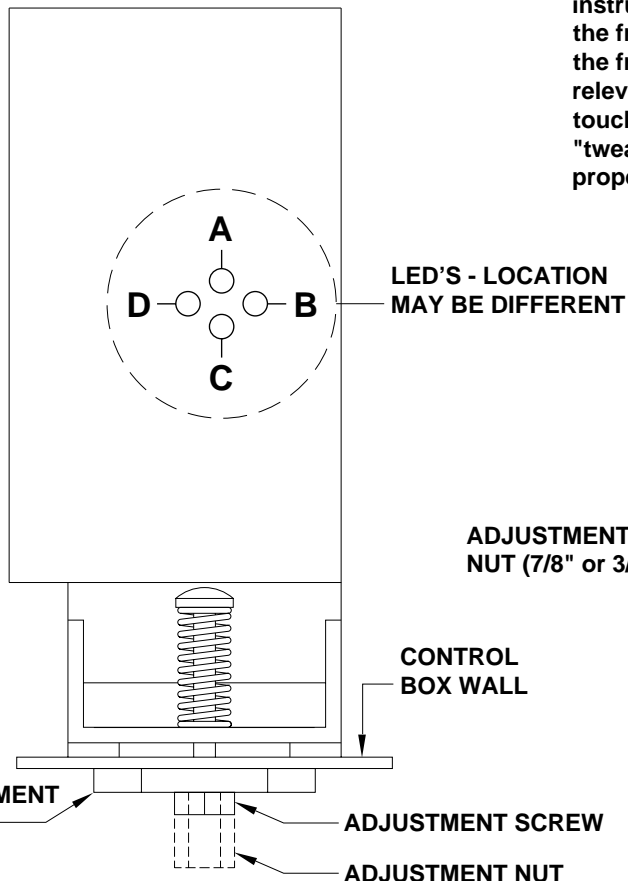

SIDE VIEW - CONTROL BOX

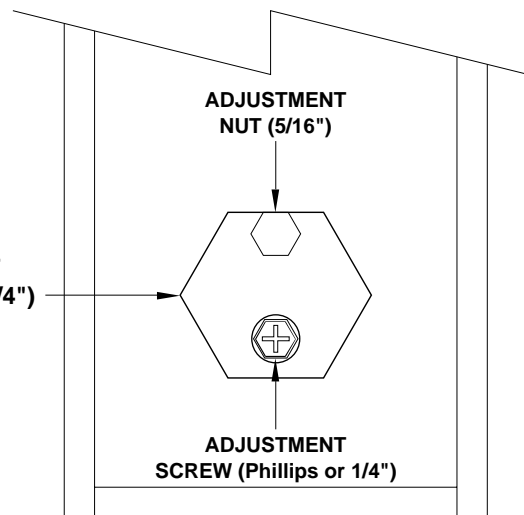

AIR LINE CONNECTION DIAGRAM

FOUR POINT AIR LEVELING WITH TAG AXLE

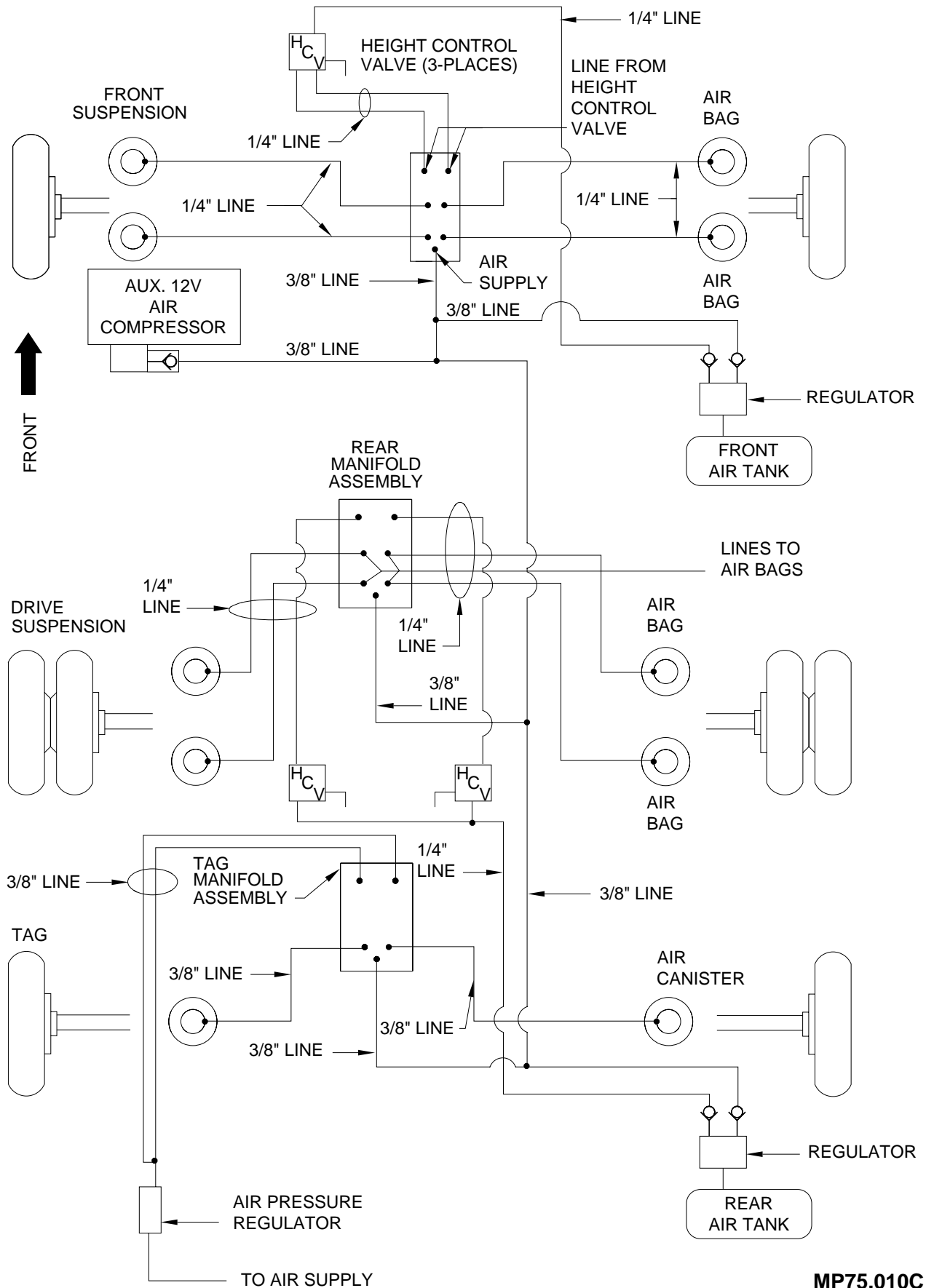

AIR LEVEL SCHEMATIC - MONACO

4-POINT LEVELING WITH AIR COMPRESSOR

PRESSURE SWITCHES FRONT AND REAR DRIVE AXLE

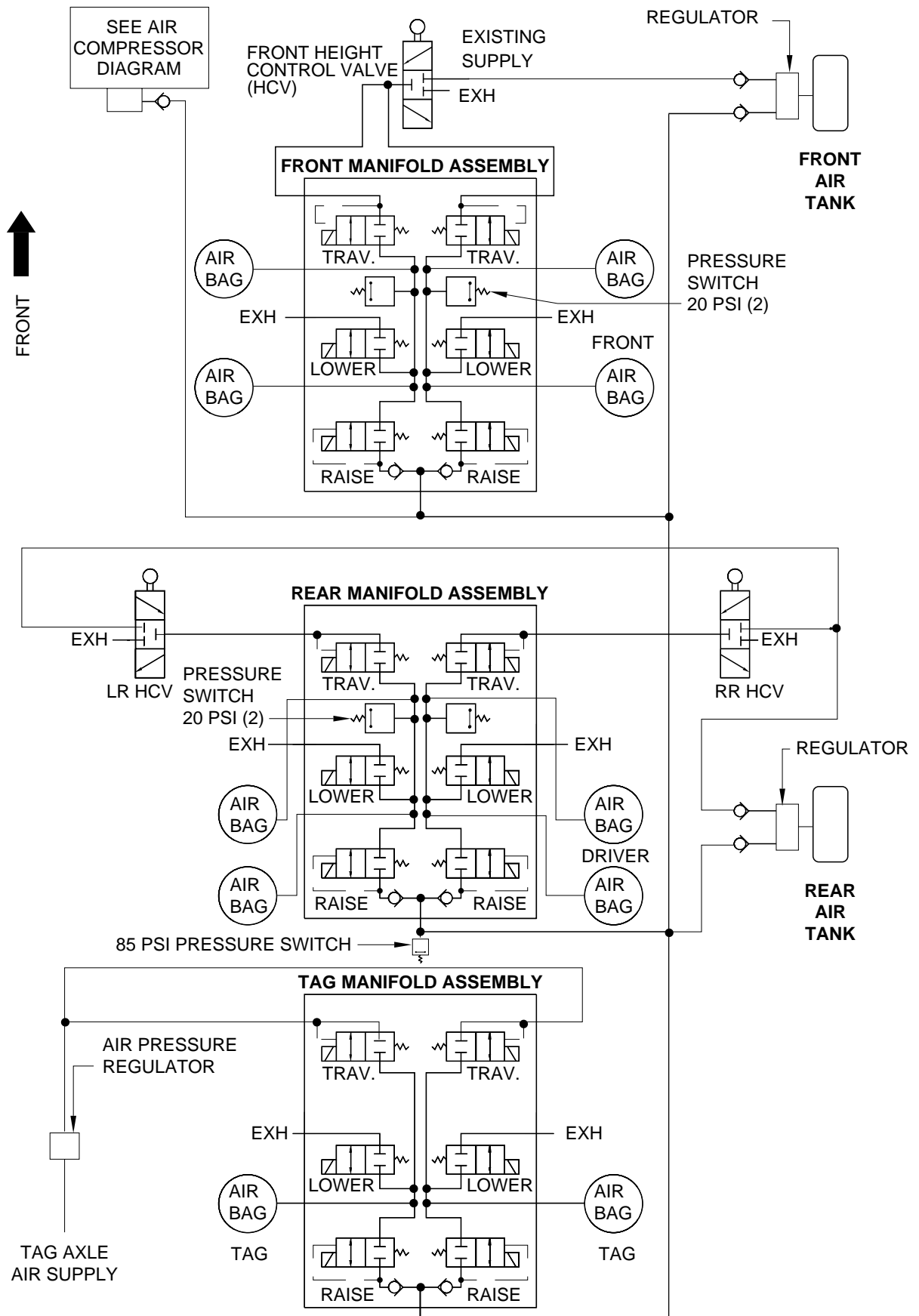

FRONT AIR SOLENOID MANIFOLD CONNECTIONS

6 VALVE WITH TWO PRESSURE SWITCHES

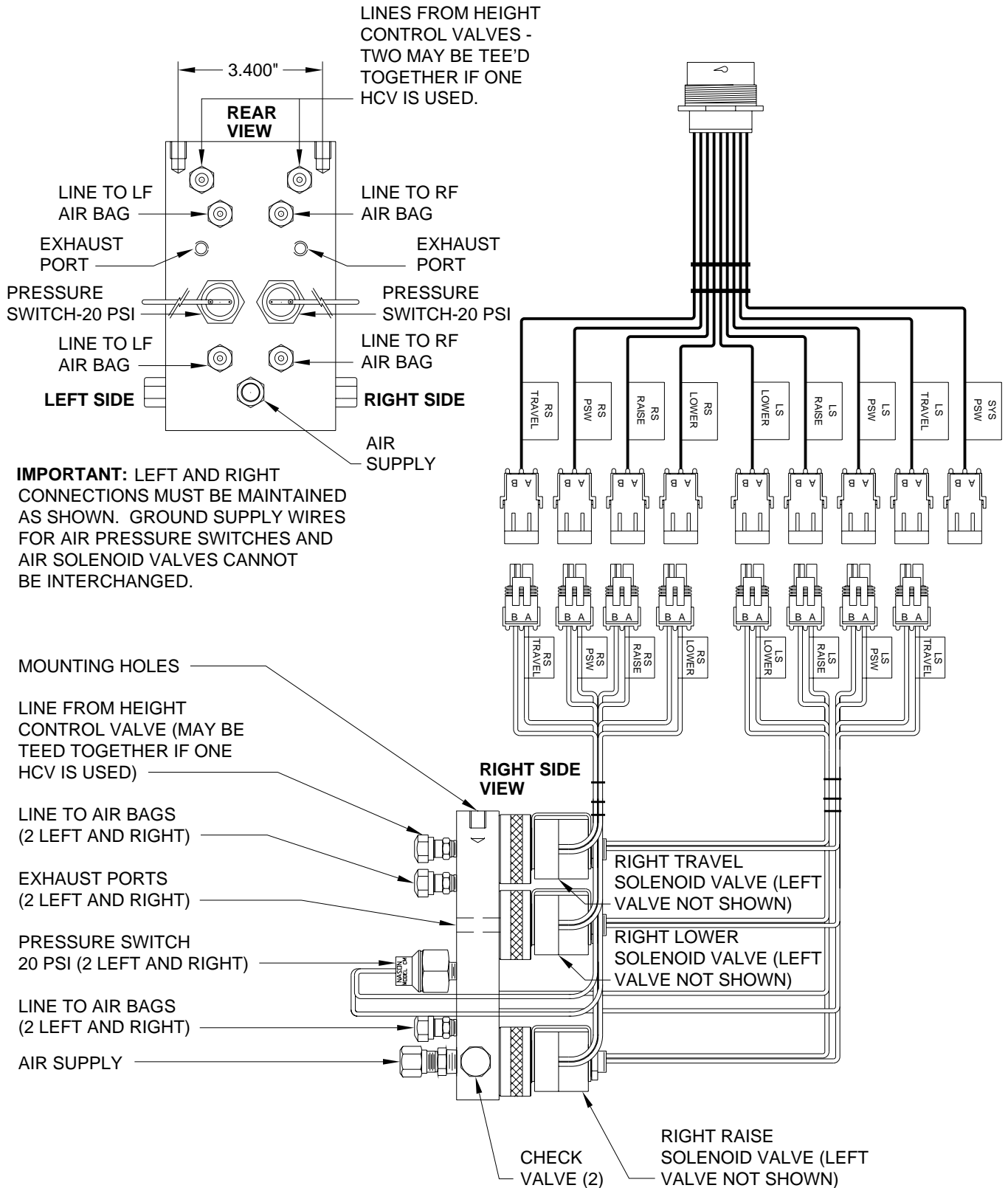

REAR AIR SOLENOID MANIFOLD CONNECTIONS

6 VALVE WITH THREE PRESSURE SWITCHES

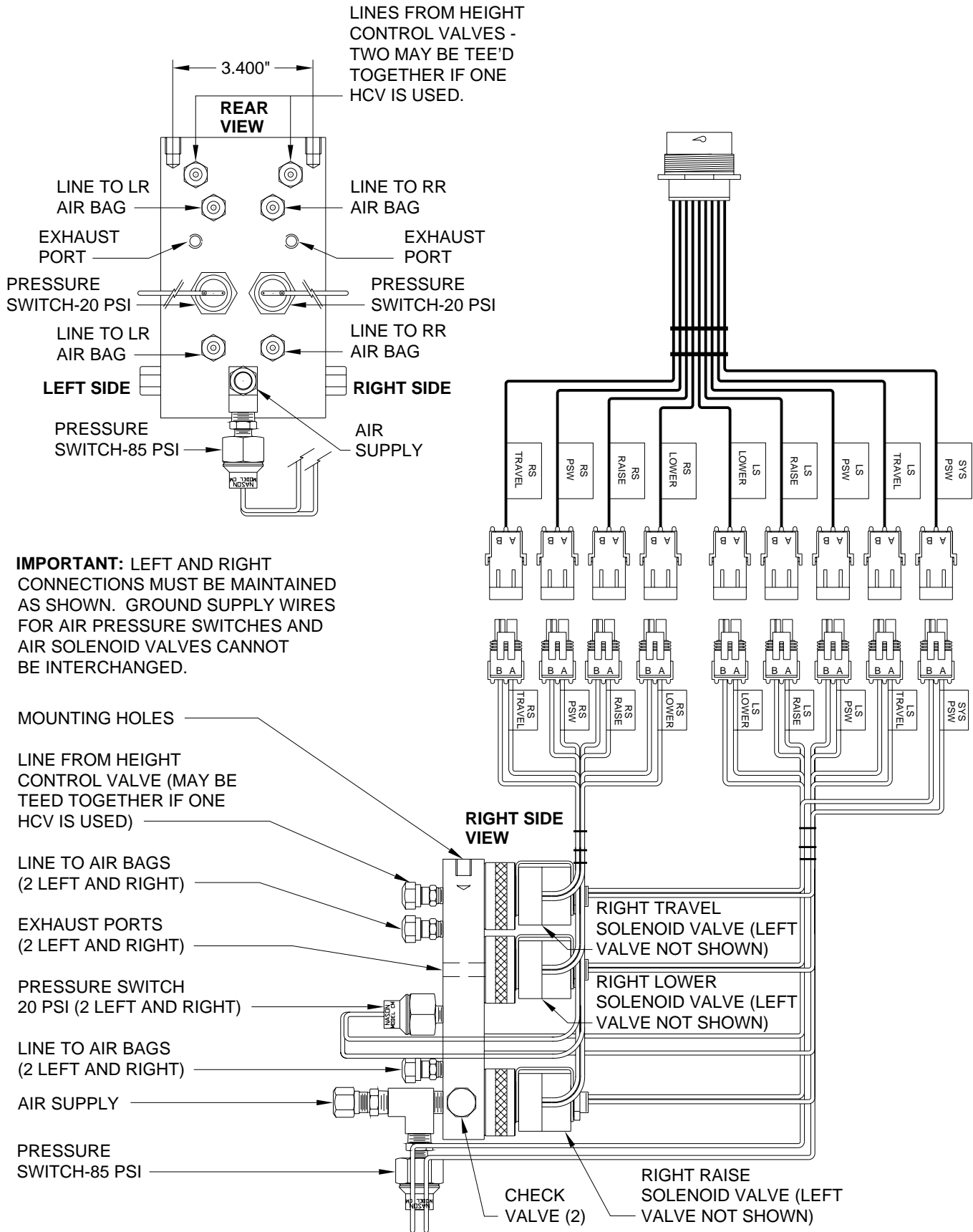

TAG AIR SOLENOID MANIFOLD CONNECTIONS

6 VALVE WITH TWO PRESSURE SWITCHES

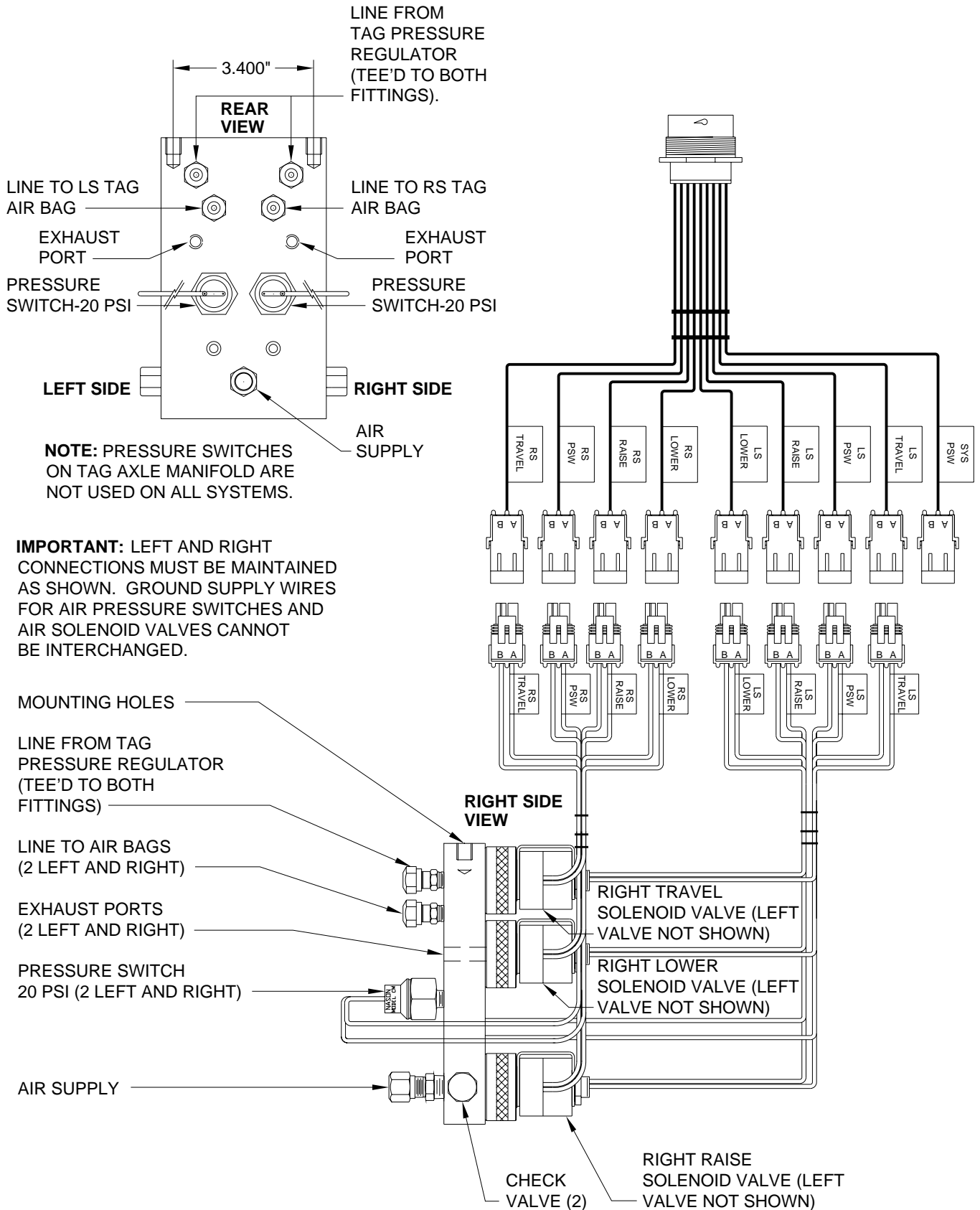

AIR COMPRESSOR DIAGRAM

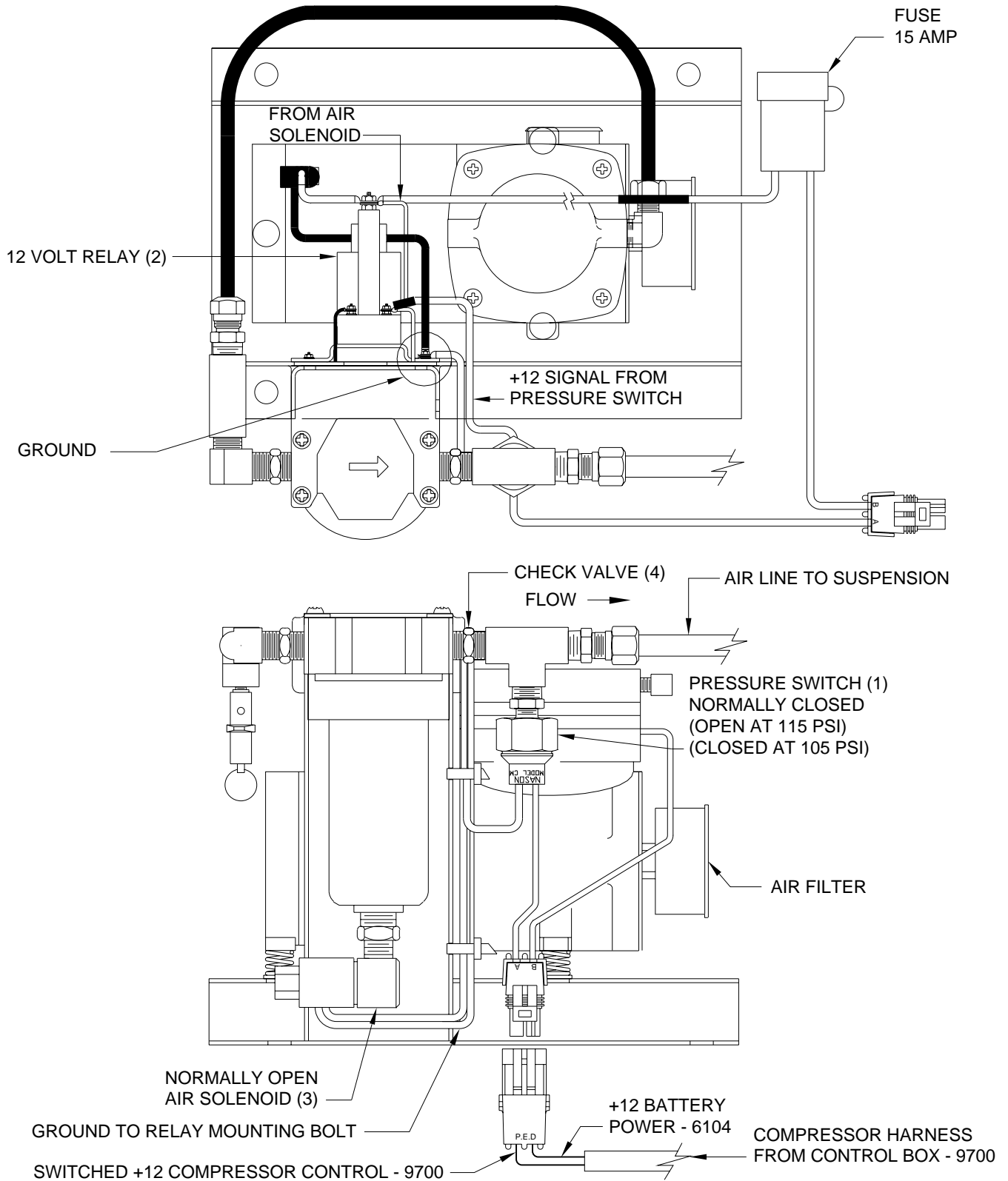

The control box sends a +12 signal to the normally closed pressure switch (1). If the pressure is low, the 12 volt relay (2) will energize and the compressor will run. The normally open air solenoid (3) will close allowing the compressor to build pressure. When the pressure builds to 115 psi the pressure switch will open, stopping the air compressor. The normally open air solenoid (3) will open, allowing internal pressure & moisture to bleed off. The check valve (4) will keep the suspension air from bleeding back to the compressor. As air pressure drops below 105 psi the compressor will start.

ELECTRICAL CONNECTION DIAGRAM

2000 SERIES CAN SYSTEM

AIR LEVELING

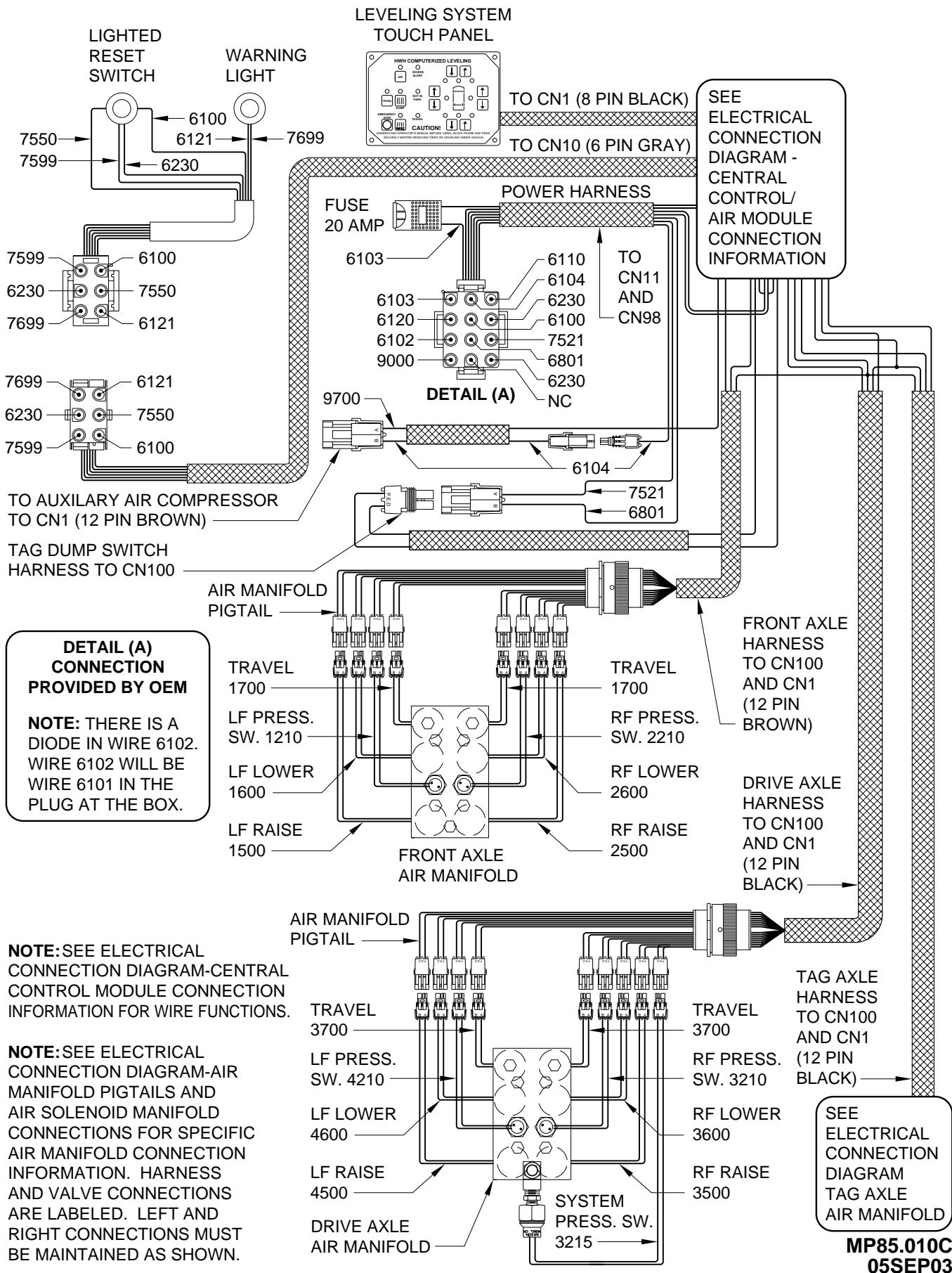

**DETAIL (A)
CONNECTION
PROVIDED BY OEM**

NOTE: THERE IS A DIODE IN WIRE 6102. WIRE 6102 WILL BE WIRE 6101 IN THE PLUG AT THE BOX.

NOTE: SEE ELECTRICAL CONNECTION DIAGRAM-CENTRAL CONTROL MODULE CONNECTION INFORMATION FOR WIRE FUNCTIONS.

NOTE: SEE ELECTRICAL CONNECTION DIAGRAM-AIR MANIFOLD PIGTAILS AND AIR SOLENOID MANIFOLD CONNECTIONS FOR SPECIFIC AIR MANIFOLD CONNECTION INFORMATION. HARNESS AND VALVE CONNECTIONS ARE LABELED. LEFT AND RIGHT CONNECTIONS MUST BE MAINTAINED AS SHOWN.

SEE ELECTRICAL CONNECTION DIAGRAM - CENTRAL CONTROL/ AIR MODULE CONNECTION INFORMATION

SEE ELECTRICAL CONNECTION DIAGRAM TAG AXLE AIR MANIFOLD

ELECTRICAL CONNECTION DIAGRAM

TAG AXLE AIR MANIFOLD

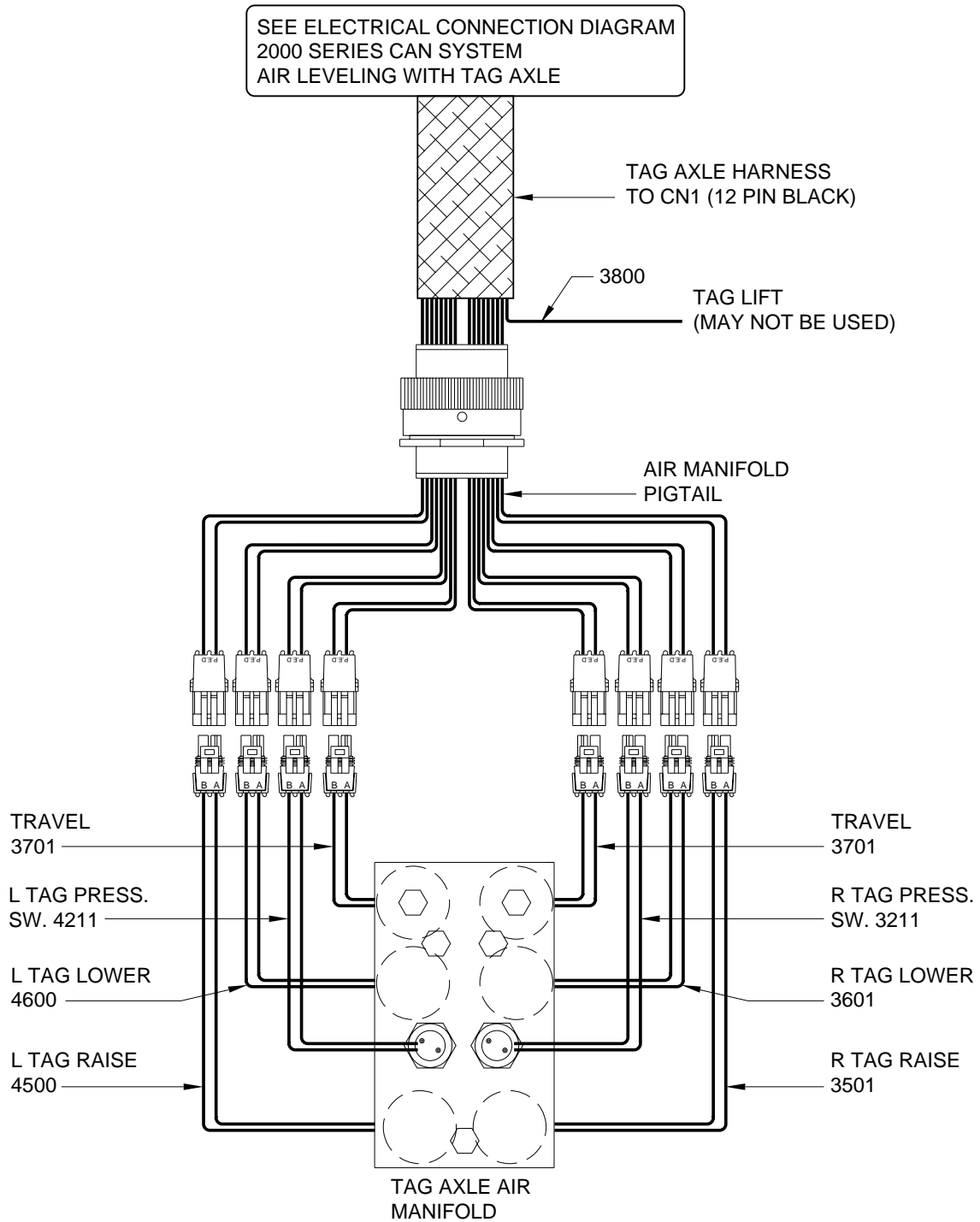

NOTE: HARNESS AND VALVE CONNECTIONS ARE LABELED. SEE TAG AIR SOLENOID MANIFOLD CONNECTIONS FOR SPECIFIC CONNECTION INFORMATION LEFT AND RIGHT CONNECTIONS MUST BE MAINTAINED AS SHOWN.

ELECTRICAL CONNECTION DIAGRAM

CENTRAL CONTROL / AIR MODULE

PAGE 1 OF 2

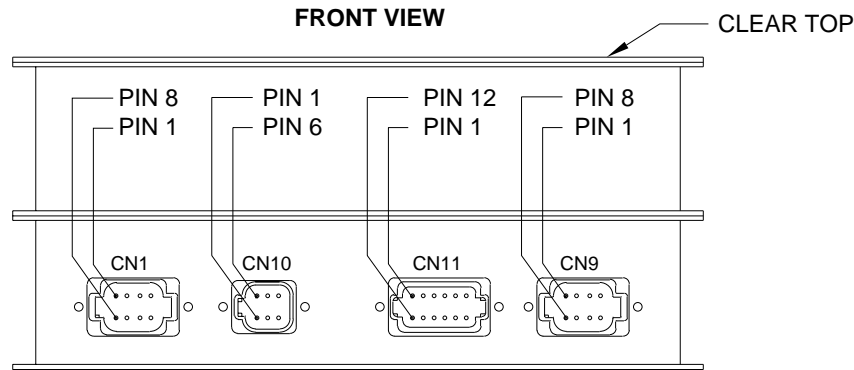

PIN #	WIRE COLOR	WIRE NUMBER	WIRE DESCRIPTION AND FUNCTION
CN1			8 PIN BLACK CONNECTOR
1	-	-	NO CONNECTION
2	-	-	NO CONNECTION
3	RED	6800	+12 SWITCHED BATTERY TO TOUCH PANEL
4	WHITE	6230	GRND TO TOUCH PANEL
5	-	-	SHIELD WIRE FOR CAN CABLE
6	-	-	NO CONNECTION
7	GREEN	-	CAN DATA LINE LOW-DO NOT MODIFY
8	YELLOW	-	CAN DATA LINE HIGH-DO NOT MODIFY
CN10			6 PIN GRAY CONNECTOR
1	BLACK	7599	RESET SWITCH LIGHT CONTROL-SWITCHED +12
2	RED	6100	RESET SWITCH SUPPLY +12
3	BLACK	7550	RESET SWITCH OUTPUT +12
4	RED	6121	WARNING LIGHT SUPPLY +12
5	WHITE	6230	RESET SWITCH LIGHT GROUND
6	BLACK	7699	WARNING LIGHT CONTROL - SWITCHED GROUND
CN11			12 PIN GRAY CONNECTOR
1	RED	6110	SWITCHED +12 FROM IGNITION
2	-	-	NO CONNECTION
3	-	-	NO CONNECTION
4	-	-	NO CONNECTION
5	RED	6120	SWITCHED +12 FROM ACCESSORY
6	RED	6100	HOUSE BATTERY +12
7	WHITE	6230	GROUND FOR PROCESSOR
8	-	-	NO CONNECTION
9	-	-	NO CONNECTION
10	-	-	NO CONNECTION
11	BLACK	9000	FROM PARK BRAKE SWITCH - SWITCHED GROUND
12	RED	6101	ENGINE BATTERY +12
CN9			8 PIN GREEN CONNECTOR
1 THRU 8	-	-	NO CONNECTION

ELECTRICAL CONNECTION DIAGRAM

CENTRAL CONTROL / AIR MODULE

PAGE 2 OF 2

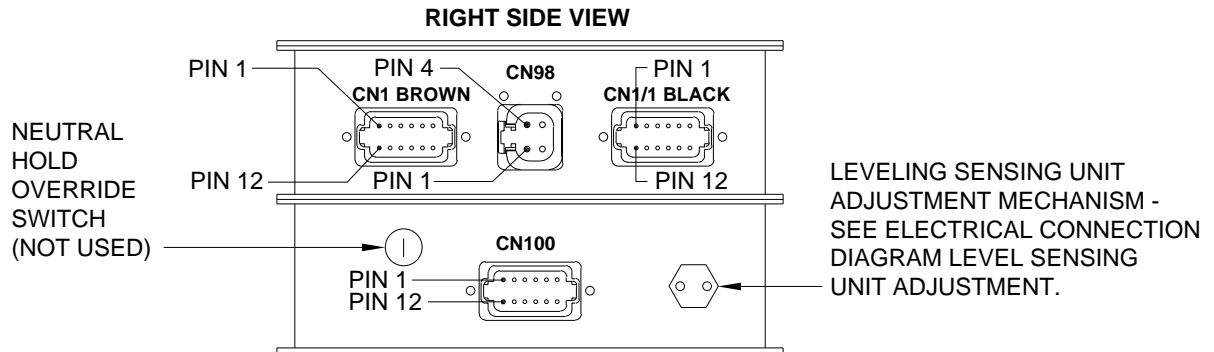

PIN #	WIRE COLOR	WIRE NUMBER	WIRE DESCRIPTION AND FUNCTION
CN1 (12 PIN BROWN)			12 PIN BROWN CONNECTOR
1			NO CONNECTION
2	BLACK	1500	LEFT FRONT RAISE AIR VALVE CONTROL - SWITCHED +12
3	BLACK	1600	LEFT FRONT LOWER AIR VALVE CONTROL - SWITCHED +12
4	BLACK	2500	RIGHT FRONT RAISE AIR VALVE CONTROL - SWITCHED +12
5	BLACK	2600	RIGHT FRONT LOWER AIR VALVE CONTROL - SWITCHED +12
6	BLACK	9700	AUXILARY AIR COMPRESSOR CONTROL - SWITCHED +12
7			NO CONNECTION
8	BLACK	1700	FRONT AIR MANIFOLD TRAVEL VALVES CONTROL - SWITCHED +12
9			NO CONNECTION
10			NO CONNECTION
11	WHITE	6254	GROUND FOR AIR SOLENOID VALVES
12			NO CONNECTION
CN98			4 PIN GRAY CONNECTOR
1	BLACK	6800	SWITCHED +12 BATTERY
2	BLACK	6800	SWITCHED +12 BATTERY
3	WHITE	6230	GROUND FROM GROUND STUD - FOR SOLENOID VALVES
4	WHITE	6230	GROUND FROM GROUND STUD - FOR SOLENOID VALVES
CN1/1 (12 PIN BLACK)			12 PIN BLACK CONNECTOR
1	BLACK	3800	TAG LIFT - SWITCHED +12
2	BLACK	4500	LEFT REAR RAISE AIR VALVE CONTROL - SWITCHED +12
3	BLACK	4600	LEFT REAR LOWER AIR VALVE CONTROL - SWITCHED +12
4	BLACK	3500	RIGHT REAR RAISE AIR VALVE CONTROL - SWITCHED +12
5	BLACK	3600	RIGHT REAR LOWER AIR VALVE CONTROL - SWITCHED +12
6			NO CONNECTION
7	BLACK	3701	TAG AIR MANIFOLD TRAVEL VALVES CONTROL - SWITCHED +12
8	BLACK	3700	REAR AIR MANIFOLD TRAVEL VALVES CONTROL - SWITCHED +12
9	BLACK	3601	RIGHT TAG LOWER AIR VALVE CONTROL - SWITCHED +12
10	BLACK	4601	LEFT TAG LOWER AIR VALVE CONTROL - SWITCHED +12
11	WHITE	6258	GROUND SUPPLY FOR REAR AND TAG AIR SOLENOID VALVES
12			NO CONNECTION
CN100			12 PIN GRAY CONNECTOR
1			NO CONNECTION
2	BLACK	1210	LEFT FRONT PRESSURE SWITCH INPUT - SWITCHED GROUND
3	BLACK	2210	RIGHT FRONT PRESSURE SWITCH INPUT - SWITCHED GROUND
4	BLACK	3210	RIGHT REAR PRESSURE SWITCH INPUT - SWITCHED GROUND
5	BLACK	4210	LEFT REAR PRESSURE SWITCH INPUT - SWITCHED GROUND
6	WHITE	6231	GROUND SUPPLY FOR ALL AIR MANIFOLD PRESSURE SWITCHES
7	BLACK	6800	SWITCHED +12 SUPPLY TO TAG DUMP SWITCH
8	BLACK	3215	AIR SYSTEM PRESSURE SWITCH - SWITCHED GROUND
9	BLACK	3211	RIGHT TAG PRESSURE SWITCH INPUT - SWITCHED GROUND
10	BLACK	4211	LEFT TAG PRESSURE SWITCH INPUT - SWITCHED GROUND
11	BLACK	7521	SWITCHED +12 FROM TAG DUMP SWITCH
12			NO CONNECTION

ELECTRICAL CONNECTION DIAGRAM

LED - FUSE LOCATION AND DESCRIPTION

CENTRAL CONTROL / AIR MODULE

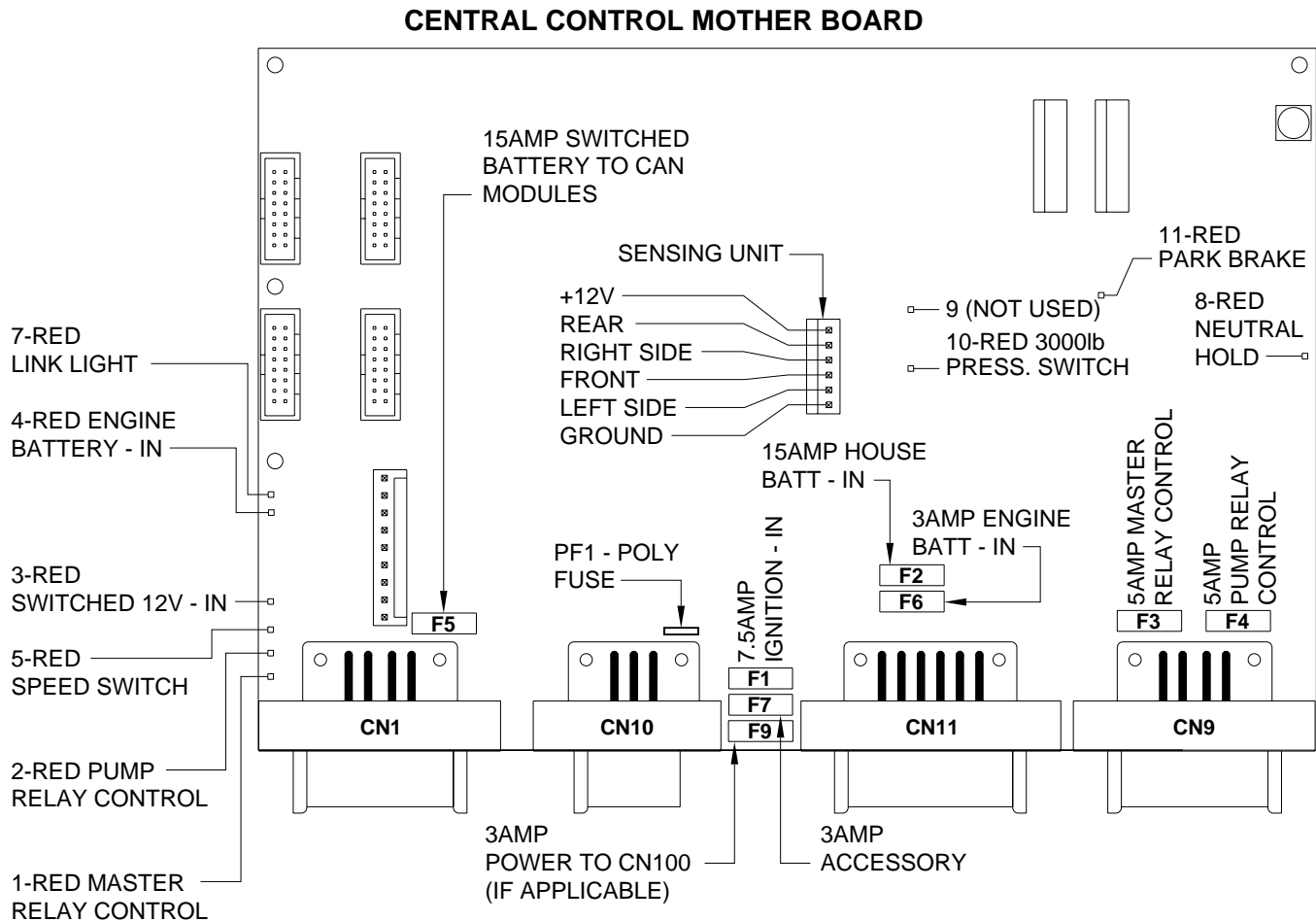

LED	DESCRIPTION	CN AND PIN	FUSE DESCRIPTION
1-RED	MASTER RELAY CONTROL (NOT USED)	CN 9 - PIN 1	PF1 - POLY FUSE
2-RED	PUMP RELAY CONTROL (NOT USED)	CN 9 - PIN 4	F1 - 7.5AMP IGNITION - IN
3-RED	SWITCHED 12V FROM MASTER RELAY	CN 1 - PIN 3	F2 - 15AMP HOUSE BATTERY - IN
4-RED	ENGINE BATTERY - IN	CN 11 - PIN 12	F3 - 5AMP MASTER RELAY CONTROL
5-RED	SPEED SWITCH	CN 9 - PIN 5	F4 - 5AMP PUMP RELAY CONTROL
7-RED	LINK LIGHT	CN 1 - PIN 7 & 8	F5 - 15AMP SWITCHED BATTERY - IN
8-RED	NEUTRAL HOLD	CN 11 - PIN 8 & 9	F6 - 3AMP RESET OUT
9-NOT USED	NOT USED	NOT USED	F7 - 3AMP ACCESSORY - IN
10-RED	3000 LBS PRESS SWITCH - ON	CN 9 - PIN 2	F9 - 3AMP POWER TO CN100 (IF APPLICABLE)
11-RED	PARK PRAKE - ON	CN 11 - PIN 11	

ALSO SEE MP85.050V FOR DIFFERENT FUSE ARRANGEMENT.

NOTE: FOR DETAILED INPUT / OUTPUT INFORMATION ABOUT PIN CONNECTIONS SEE ELECTRICAL CONNECTION DIAGRAM - CENTRAL CONTROL / AIR MODULE CONNECTION INFORMATION.

ELECTRICAL CONNECTION DIAGRAM

LED - FUSE LOCATION AND DESCRIPTION

CENTRAL CONTROL / AIR MODULE

CENTRAL CONTROL MOTHER BOARD

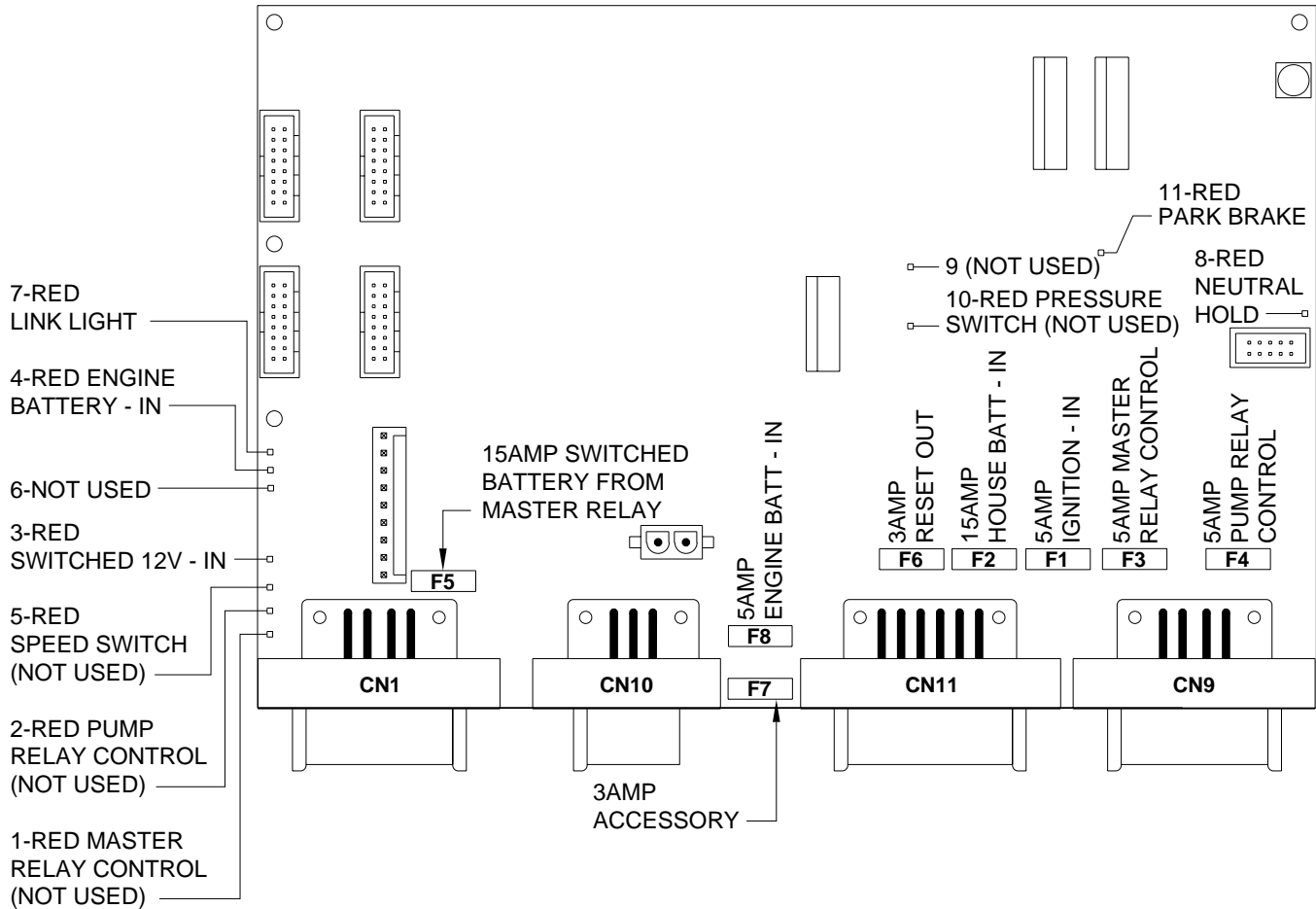

LED	DESCRIPTION	CN AND PIN	FUSE DESCRIPTION
1-RED	MASTER RELAY CONTROL (NOT USED)	CN 9 - PIN 1	F1 - 5AMP IGNITION - IN
2-RED	PUMP RELAY CONTROL (NOT USED)	CN 9 - PIN 4	F2 - 15AMP HOUSE BATTERY - IN
3-RED	SWITCHED 12V FROM MASTER RELAY	CN 1 - PIN 3	F3 - 5AMP MASTER RELAY CONTROL
4-RED	ENGINE BATTERY - IN	CN 11 - PIN 12	F4 - 5AMP PUMP RELAY CONTROL
5-RED	SPEED SWITCH (NOT USED)	CN 9 - PIN 5	F5 - 15AMP SWITCHED BATTERY - IN
6-NOT USED	NOT USED	NOT USED	F6 - 3AMP RESET OUT
7-RED	LINK LIGHT	CN 1 - PIN 7 & 8	F7 - 3AMP ACCESSORY - IN
8-RED	NEUTRAL HOLD	CN 11 - PIN 8 & 9	F8 - 5AMP ENGINE BATTERY - IN
9-NOT USED	NOT USED	NOT USED	
10-RED	3000 LBS PRESS SWITCH - ON (NOT USED)	CN 9 - PIN 2	
11-RED	PARK PRAKE - ON	CN 11 - PIN 11	

NOTE: FOR DETAILED INPUT / OUTPUT INFORMATION ABOUT PIN CONNECTIONS SEE ELECTRICAL CONNECTION DIAGRAM - CENTRAL CONTROL / AIR MODULE CONNECTION INFORMATION.

ELECTRICAL CONNECTION DIAGRAM

LED - FUSE LOCATION AND DESCRIPTION

CENTRAL CONTROL / AIR MODULE

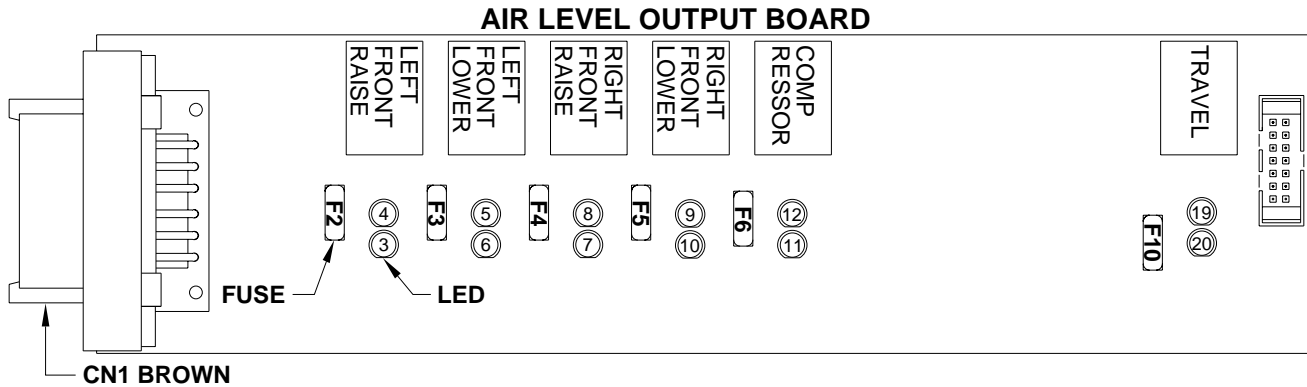

LED	RELAY DESCRIPTION	FUSE	BROWN
3-RED	LEFT FRONT RAISE	F2-5 AMP	PIN 2
4-YELLOW	LEFT FRONT RAISE		
5-YELLOW	LEFT FRONT LOWER		
6-RED	LEFT FRONT LOWER	F3-5 AMP	PIN 3
7-RED	RIGHT FRONT RAISE	F4-5 AMP	PIN 4
8-YELLOW	RIGHT FRONT RAISE		
9-YELLOW	RIGHT FRONT LOWER		
10-RED	RIGHT FRONT LOWER	F5-5 AMP	PIN 5
11-RED	COMPRESSOR	F6-5 AMP	PIN 6
12-YELLOW	COMPRESSOR		
19-YELLOW	TRAVEL		
20-RED	TRAVEL	F10-7.5 AMP	PIN 8

NOTE: THE TRAVEL RELAY IS WIRED AS A NORMALLY CLOSED RELAY. WHEN THE YELLOW LED (19) IS ON THE RELAY CONTACTS WILL OPEN. THE RED LED (20) WILL NOT BE ON. THE RED LED WILL BE ON IF THE LEVELING SYSTEM IS IN THE TRAVEL MODE AND THE IGNITION IS ON.

NOTE: FOR DETAILED INPUT / OUTPUT INFORMATION ABOUT PIN CONNECTIONS SEE ELECTRICAL CONNECTION DIAGRAM - CENTRAL CONTROL / AIR MODULE CONNECTION INFORMATION.

NOTE: A LIT YELLOW LED INDICATES THERE IS A GROUND SIGNAL TO TURN THE CORRESPONDING RELAY ON.

A LIT RED LED INDICATES THERE IS VOLTAGE ON IT'S CORRESPONDING PIN.

IF A YELLOW LED IS LIT AND THE CORRESPONDING RED LED IS OFF, EITHER IT'S FUSE IS BLOWN OR THE RELAY IS BAD.

IF THE YELLOW LEDS ARE WORKING BUT NO RED LED IS COMING ON THERE IS A PROBLEM WITH INPUT VOLTAGE IN THE 4-PIN CONNECTOR ON THE MIDDLE RING.

IF A YELLOW LED IS NOT LIT, THIS INDICATES A PROBLEM WITH A MODULE.

ELECTRICAL CONNECTION DIAGRAM

LED - FUSE LOCATION AND DESCRIPTION

CENTRAL CONTROL / AIRMODULE

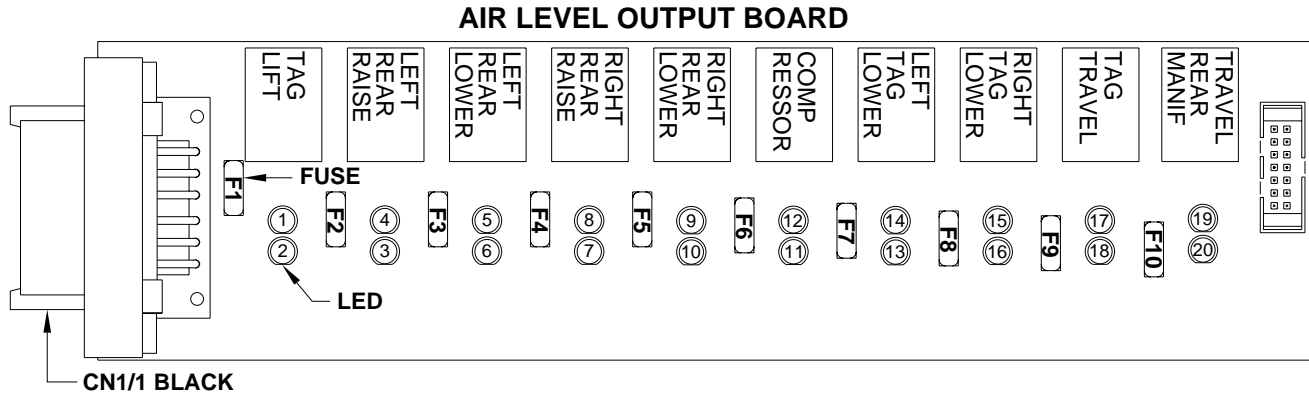

LED	RELAY DESCRIPTION	FUSE	BLACK
1-YELLOW	TAG LIFT		
2-RED	TAG LIFT	F1-5 AMP	PIN 1
3-RED	LEFT REAR RAISE	F2-5 AMP	PIN 2
4-YELLOW	LEFT REAR RAISE		
5-YELLOW	LEFT REAR LOWER		
6-RED	LEFT REAR LOWER	F3-5 AMP	PIN 3
7-RED	RIGHT REAR RAISE	F4-5 AMP	PIN 4
8-YELLOW	RIGHT REAR RAISE		
9-YELLOW	RIGHT REAR LOWER		
10-RED	RIGHT REAR LOWER	F5-5 AMP	PIN 5
11-RED	COMPRESSOR	F6-5 AMP	NC
12-YELLOW	COMPRESSOR		
13-RED	LEFT TAG LOWER	F7-5 AMP	PIN 10
14-YELLOW	LEFT TAG LOWER		
15-YELLOW	RIGHT TAG LOWER		
16-RED	RIGHT TAG LOWER	F8-5 AMP	PIN 9
17-YELLOW	TAG TRAVEL		
18-RED	TAG TRAVEL	F9-3 AMP	PIN 7
19-YELLOW	TRAVEL - REAR MANIFOLD		
20-RED	TRAVEL - REAR MANIFOLD	F10-3 AMP	PIN 8

NOTE: FOR DETAILED INPUT / OUTPUT INFORMATION ABOUT PIN CONNECTIONS SEE ELECTRICAL CONNECTION DIAGRAM - CENTRAL CONTROL / AIR MODULE CONNECTION INFORMATION.

NOTE: A LIT YELLOW LED INDICATES THERE IS A GROUND SIGNAL TO TURN THE CORRESPONDING RELAY ON.

A LIT RED LED INDICATES THERE IS VOLTAGE ON IT'S CORRESPONDING CN1 PIN.

IF A YELLOW LED IS LIT AND THE CORRESPONDING RED LED IS OFF, EITHER IT'S FUSE IS BLOWN OR THE RELAY IS BAD.

IF THE YELLOW LEDS ARE WORKING BUT NO RED LED IS COMING ON THERE IS A PROBLEM WITH INPUT VOLTAGE IN THE 4-PIN CONNECTOR ON THE TOP RING.

IF A YELLOW LED IS NOT LIT, THIS INDICATES A PROBLEM WITH A MODULE.

NOTE: THE TWO TRAVEL RELAYS ARE WIRED AS NORMALLY CLOSED RELAYS. WHEN THE YELLOW LED (19) IS ON THE RELAY CONTACTS WILL OPEN. THE RED LED (20) WILL NOT BE ON. THE RED LED WILL BE ON IF THE LEVELING SYSTEM IS IN THE TRAVEL MODE AND THE IGNITION IS ON.