

# LED LEGEND

## 325 SERIES LEVELING SYSTEM

### TOUCH PANEL WITH "NOT IN PARK/BRAKE" LIGHT

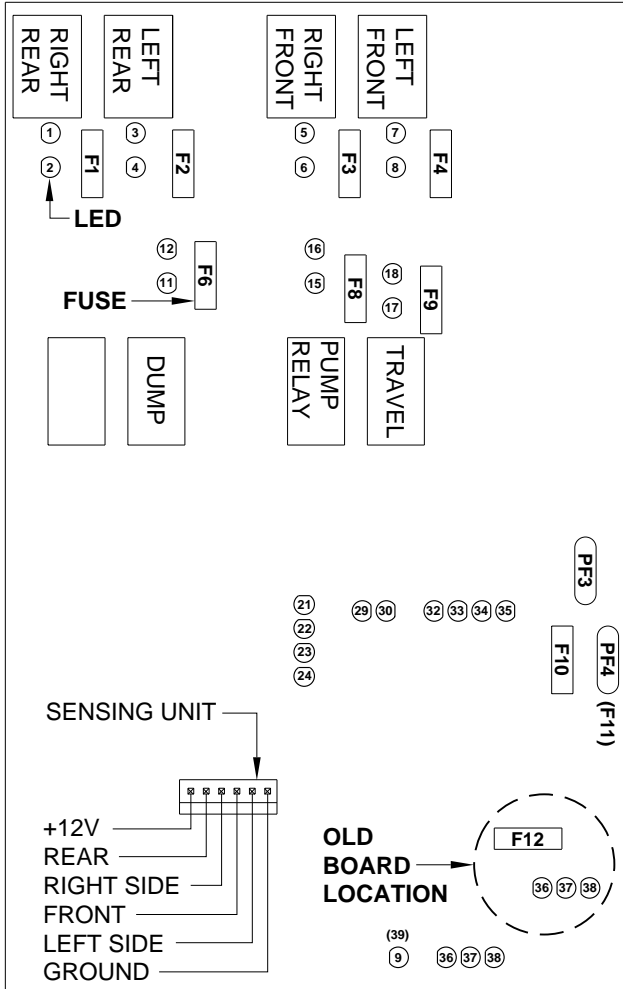

FUSE	SIZE	DESCRIPTION
F1	15AMP	Fuse for Right Rear solenoid valve. LED 2 will not come on if this fuse is blown.
F2	15AMP	Fuse for Left Rear solenoid valve. LED 4 will not come on if this fuse is blown.
F3	15AMP	Fuse for Right Front solenoid valve. LED 6 will not come on if this fuse is blown.
F4	15AMP	Fuse for Left Front solenoid valve. LED 8 will not come on if this fuse is blown.
F6	5AMP	Fuse for Air Dump output. LED 12 will not come on if this fuse is blown.
F8	5AMP	Fuse for the Pump Relay control output. LED 16 will not come on if this fuse is blown.
F9	5AMP	Fuse for Travel output. LED 18 will not come on if this fuse is blown.
F10	10AMP	This is the Main fuse for the Control Box. The box would be bad if this fuse is blown.
PF4 (F11)	(3AMP)	Protection (Fuse) for the Power Supply for the Master Warning indicators.
PF3 (F12)	(7.5AMP)	Protection (Fuse) for the Power Supply wire for the Touch Panel.

**NOTE: On newer control boxes, FUSE F11 and FUSE F12 have been replaced with POLY SWITCHES PF4 and PF3. Poly switches protect a component or wire as a fuse does except the poly switch will allow current through when the overload or short is removed. Poly switches are not replaceable.**

LED #	COLOR	DESCRIPTION
1	YELLOW	On indicates there is a signal to turn the relay on that operates the Right Rear solenoid valve.
2	RED	On indicates there is a 12 volt output on the pin for the Right Rear solenoid valve.
3	YELLOW	On indicates there is a signal to turn the relay on that operates the Left Rear solenoid valve.
4	RED	On indicates there is a 12 volt output on the pin for the Left Rear solenoid valve.
5	YELLOW	On indicates there is a signal to turn the relay on that operates the Right Front solenoid valve.
6	RED	On indicates there is a 12 volt output on the pin for the Right Front solenoid valve.
7	YELLOW	On indicates there is a signal to turn the relay on that operates the Left Front solenoid valve.
8	RED	On indicates there is a 12 volt output on the pin for the Left Front solenoid valve.
9	RED	Link Light - will be on, pulsating whenever the ignition switch is in the "ON" or "ACC" position.

(39)

**LED LEGEND**  
**325 SERIES LEVELING SYSTEM**  
**TOUCH PANEL WITH "NOT IN PARK/BRAKE" LIGHT**

LED #	COLOR	DESCRIPTION
11	YELLOW	On indicates there is a signal to turn the relay on that supplies a 12 volt output to the Air Dump system, if applicable.
12	RED	On indicates there is a 12 volt output on the pin for Air Dump, if applicable.
15	YELLOW	On indicates there is a signal to turn the relay on that controls the Pump Relay on the pump motor.
16	RED	On indicates there is a 12 volt output on the pin that controls the Pump Relay on the pump motor.
17	YELLOW	On indicates there is a signal to turn the relay on that controls the output for the TRAVEL signal if the vehicle has a pilot air dump system. This relay is wired normally closed. The RED #18 LED should be off when #17 LED is on. 17 will be on anytime the ignition is on if the system is not in the TRAVEL mode. <b>NOTE: TRAVEL MODE is achieved when the ignition is ON and the "STORE" button is pushed or the park brake is released.</b>
18	RED	On indicates there is a 12 volt signal on the pin for TRAVEL if the vehicle is equipped with a pilot air dump. This LED will be on anytime the ignition is ON and the system is in the TRAVEL mode.
21	YELLOW	On indicates there is a ground input from the Left Front Jack Warning Switch.
22	YELLOW	On indicates there is a ground input from the Right Front Jack Warning Switch.
23	YELLOW	On indicates there is a ground input from the Right Rear Jack Warning Switch.
24	YELLOW	On indicates there is a ground input from the Left Rear Jack Warning Switch.
29	RED	NOT USED
30	YELLOW	NOT USED
32	RED	On indicates there is a ground output to turn the Master Warning indicators on.
33	GREEN	On indicates there is a ground input from the 50# pressure switch on the leveling system manifold.
34	RED	On indicates there is a signal to turn the pump on from a room control switch. Jack solenoid valves will not operate when this LED is on.
35	RED	On indicates there is a ground input on the pin for the Park Brake Switch wire.
36	RED	Board enable - this LED should be on whenever the ignition switch is in the "ON" or "ACC" position.
37	RED	On whenever the ignition switch is in the "ON" or "ACC" position. There will be 12 volts on the "ACC" in pin.
38	RED	On whenever the ignition switch is in the "ON" or "ACC" position. There will be 12 volts on the Master Warning supply pin.
39 (9)	RED	Link Light - will flash on and off whenever the ignition switch is in the "ON" or "ACC" position. This LED will be off if communication with the Touch Panel is lost.