



OPERATOR'S MANUAL

HWH® COMPUTER-CONTROLLED 2000 SERIES LEVELING SYSTEM

FEATURING:

Touch Panel Leveling Control

BI-AXIS® Hydraulic Leveling

Straight-Acting Jacks

Multiple Room Extensions (with Air Seals)

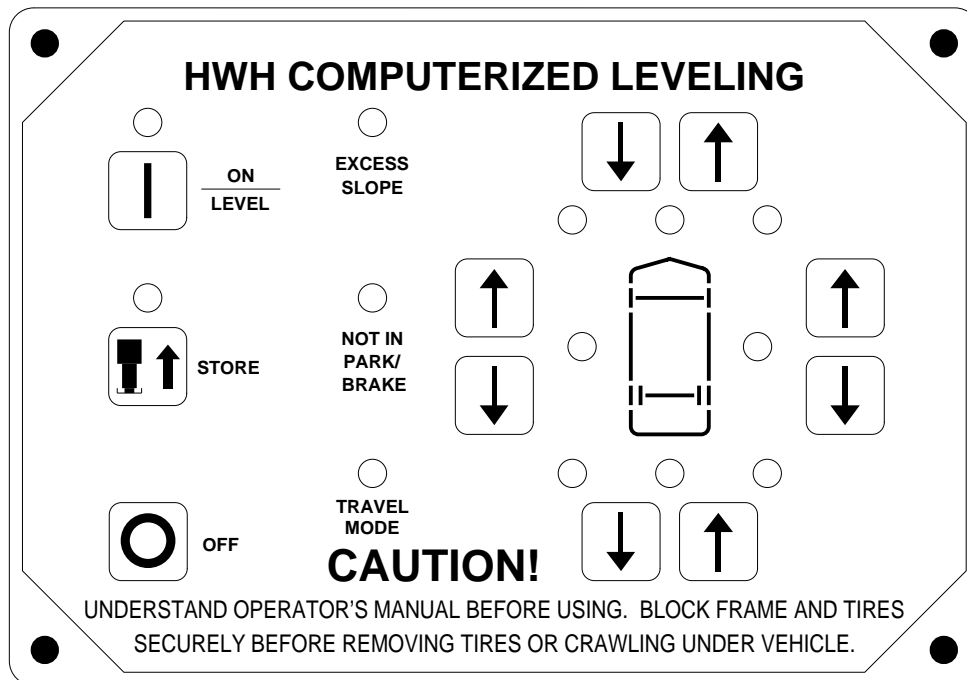

HWH CORPORATION

(On I-80, Exit 267 South)

2096 Moscow Road | Moscow, Iowa 52760

Ph: 800/321-3494 (or) 563/724-3396 | Fax: 563/724-3408

www.hwh.com

OPERATING MANUAL

CAUTION !

READ THE ENTIRE OPERATOR'S MANUAL BEFORE OPERATING.

BLOCK FRAME AND TIRES SECURELY BEFORE CRAWLING UNDER VEHICLE. DO NOT USE LEVELING JACKS OR AIR SUSPENSION TO SUPPORT VEHICLE WHILE UNDER VEHICLE OR CHANGING TIRES. VEHICLE MAY DROP AND/OR MOVE FORWARD OR BACKWARD WITHOUT WARNING CAUSING INJURY OR DEATH.

KEEP ALL PEOPLE CLEAR OF VEHICLE WHILE LEVELING SYSTEM AND ROOM EXTENSION ARE BEING OPERATED.

NEVER PLACE HANDS OR OTHER PARTS OF THE BODY NEAR HYDRAULIC LEAKS. OIL MAY PENETRATE SKIN CAUSING INJURY OR DEATH.

WEAR SAFETY GLASSES WHEN INSPECTING OR SERVICING THE SYSTEM TO PROTECT EYES FROM DIRT, METAL CHIPS, OIL LEAKS, ETC. FOLLOW ALL OTHER APPLICABLE SHOP SAFETY PRACTICES.

IMPORTANT: IF COACH IS EQUIPPED WITH A ROOM EXTENSION, READ ROOM EXTENSION SECTION BEFORE OPERATING LEVELING SYSTEM.

HOW TO OBTAIN WARRANTY SERVICE

THIS IS NOT TO BE INTERPRETED AS A STATEMENT OF WARRANTY

HWH CORPORATION strives to maintain the highest level of customer satisfaction. Therefore, if you discover a defect or problem, please do the following:

FIRST: Notify the dealership where you purchased the vehicle or had the leveling system installed. Dealership management people are in the best position to resolve the problem quickly. If the dealer has difficulty solving the problem, he should immediately contact the Customer Service Department, at HWH CORPORATION.

SECOND: If your dealer cannot or will not solve the problem, notify the Customer Service Department:
HWH CORPORATION 2096 Moscow Rd. Moscow IA. 52760
(563) 724-3396 OR (800) 321-3494. Give your name and address, coach manufacturer and model year, date the coach was purchased, or the date of system installation,

description of the problem, and where you can be reached during business hours (8:00 a.m. till 5:00 p.m. c.s.t.). HWH CORPORATION personnel will contact you to determine whether or not your claim is valid. If it is, HWH CORPORATION will authorize repair or replacement of the defective part, either by appointment at the factory or by the authorization of an independent service facility, to be determined by HWH CORPORATION. All warranty repairs must be performed by an independent service facility authorized by HWH CORPORATION, or at the HWH CORPORATION factory, unless prior written approval has been obtained from proper HWH CORPORATION personnel.

CONTROL IDENTIFICATION

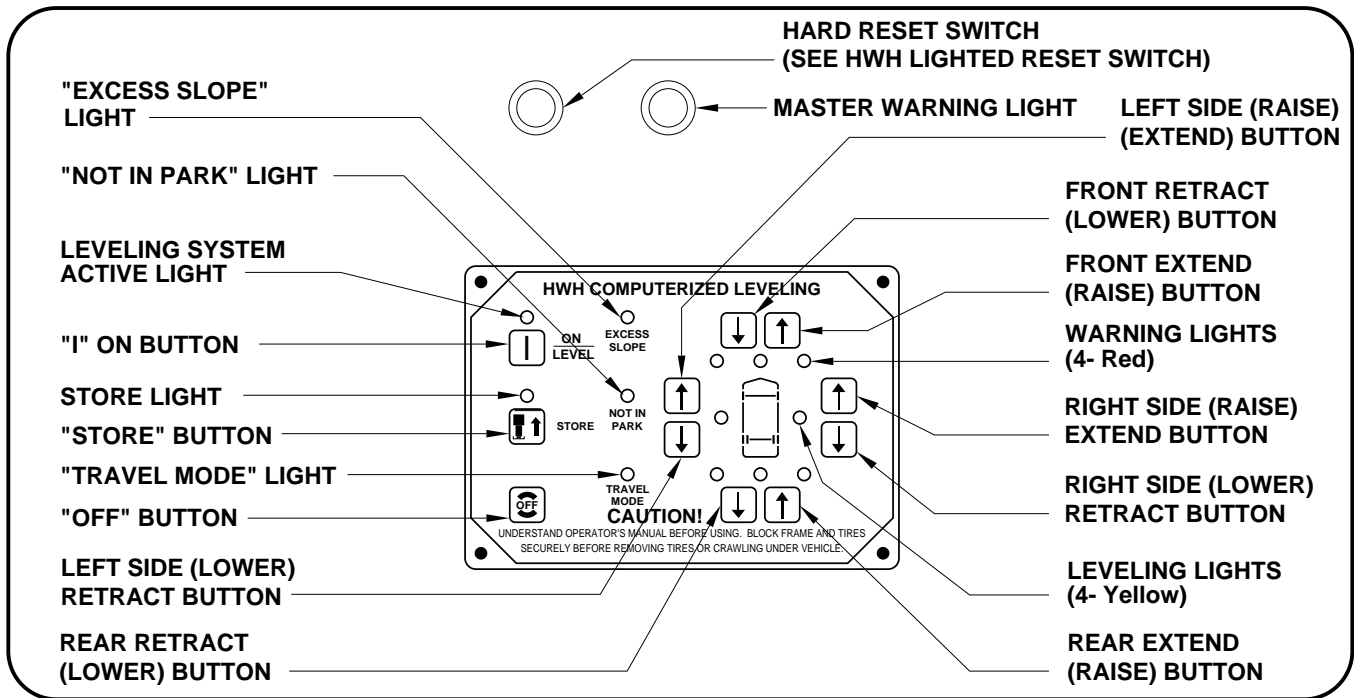

CONTROL FUNCTIONS

CONTROLS

"I" BUTTON: This is the ON button and automatic operation button. The vehicle ignition must be in the "ON" or "ACC" position.

"STORE" BUTTON: This button is used to automatically retract the jacks. The Leveling System must be ON to use the "STORE" button.

"OFF" BUTTON: This button will turn the Leveling System OFF and stop any Leveling System operations.

UP ARROWS (RAISE BUTTONS): These momentary buttons are used for manually extending the leveling jacks. Sides or ends of the vehicle will raise while these buttons are pushed.

DOWN ARROWS (LOWER BUTTONS): These momentary buttons are used for manually retracting the leveling jacks. Sides or ends of the vehicle will lower while these buttons are pushed.

INDICATOR LIGHTS

LEVELING LIGHTS: The four yellow indicating lights are level sensing indicators. When a yellow light is on, it indicates that its side or end of the vehicle is low. No more than two lights should be on at the same time.

STORE LIGHT: This light will flash when the system is in the STORE mode.

WARNING LIGHTS: The four red lights surrounding the yellow level indicators are jack WARNING lights. They are functional when the ignition is in the "ON" or "ACC" position. A lit WARNING light indicates that jack is extended 1/4" to 1/2" or more.

"EXCESS SLOPE" LIGHT: This indicator will light when the leveling system cannot level the vehicle.

"NOT IN PARK/BRAKE" LIGHT: This indicator will light when the ON button is pushed and the hand/auto park brake is not set. The "NOT IN PARK/BRAKE" light will go out when the ON button is released.

"TRAVEL MODE" LIGHT: This indicator light will be ON when the ignition is ON, when the jacks are retracted, and there are no red WARNING lights ON.

MASTER WARNING LIGHT: This is a light mounted separate from the touch panel. It will be ON when any one or more jacks are extended 1/4" to 1/2" or more.

CONTROL IDENTIFICATION

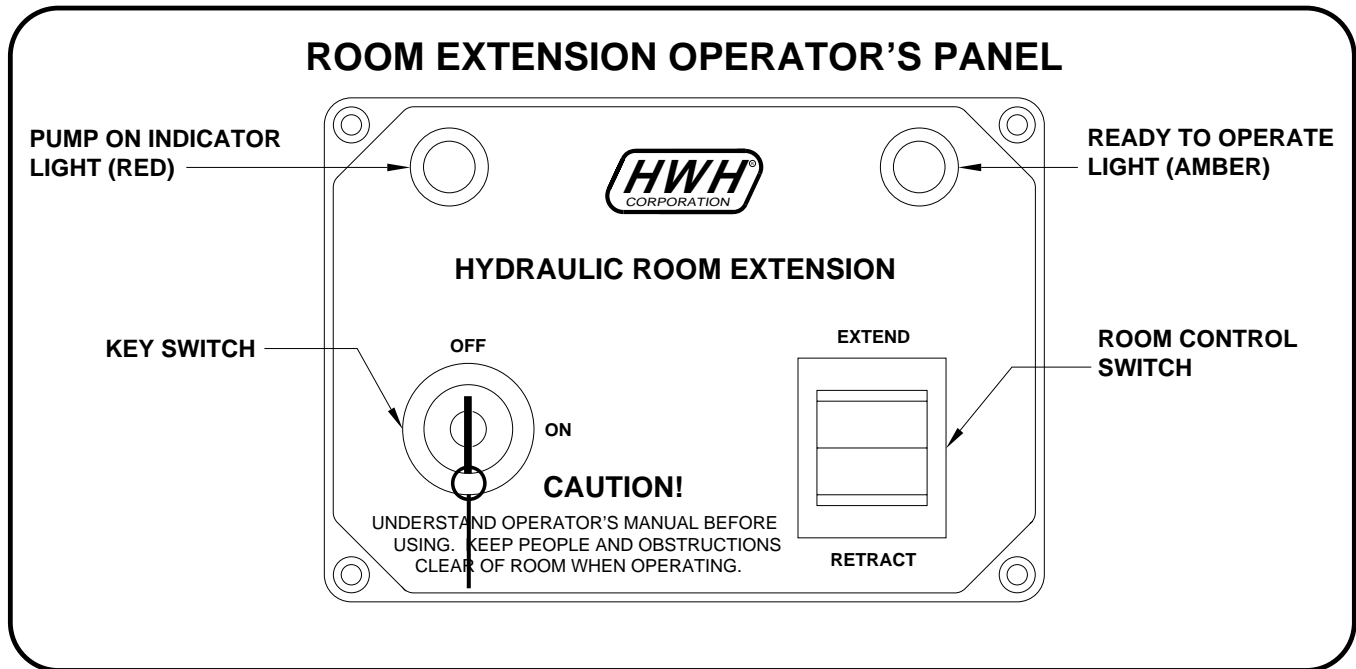

CONTROL FUNCTIONS

KEY SWITCH: The KEY SWITCH controls power to the ROOM CONTROL SWITCH. When the KEY SWITCH is in the "ON" POSITION the room can be operated, and the key cannot be removed. When the KEY SWITCH is in the "OFF" position the room cannot be operated, and the key can be removed.

NOTE: Any time the KEY SWITCH is ON, the network will be active and will not power down.

ROOM CONTROL SWITCH: The ROOM CONTROL SWITCH is a two position momentary switch. Pressing the switch in the EXTEND POSITION will extend the room. Pressing the switch in the RETRACT POSITION will retract the room. Releasing the ROOM CONTROL SWITCH will halt the operation of the room.

PUMP ON INDICATOR LIGHT: This light will be on when the pump is running.

READY TO OPERATE LIGHT: This light will flash for 20 seconds while the air seal deflates, after the KEY SWITCH is turned on. It will then glow steady. The room cannot be extended or retracted if this light is flashing.

If the "EXCESS SLOPE" light on the leveling system control panel is on, the READY TO OPERATE light will flash when the room control switch is pushed to "EXTEND". The room will not extend. The room will retract if the room control switch is pushed to "RETRACT".

If the PARK BRAKE is not set, the READY TO OPERATE light will not turn on and flash when the KEY SWITCH is turned "ON".

If a leveling function of the Leveling System is in use, MANUAL or AUTOMATIC operation, the READY TO OPERATE light will flash if the KEY SWITCH is in the "ON" position. The room will not operate. The room can be operated if the Leveling System is in the "STORE" mode.

OPERATING PROCEDURES

GENERAL INSTRUCTIONS

Maintain adequate clearance in all directions for vehicles, room extensions, doors, steps, etc.. Vehicle may move in any direction due to raising or lowering of vehicle during leveling, settling of vehicle, equipment malfunction, etc..

If parking on soft ground or asphalt paving, a wood block or pad should be placed under each jack.

The MASTER WARNING LIGHT will be ON if the ignition is in the "ON" position and any jack is extended 1/4" to 1/2" or more.

CAUTION: DO NOT MOVE THE VEHICLE IF A ROOM IS EXTENDED.

Press the "OFF" button to stop operation of the Leveling System.

If the Park Brake is not set, the Leveling System cannot be turned ON and the room extension will not operate.

If a ROOM CONTROL SWITCH is being pushed, the Leveling System can not be operated. If any Leveling System leveling function is being operated, no room control switch will work. The room can be operated if the Leveling System is in the STORE mode.

The Leveling System should be operated once a month or whenever the vehicle is used, to keep the system in operating condition.

HWH LIGHTED RESET SWITCH

The HWH lighted reset switch is located on the vehicle overhead panel. If there is a failure at any time in the HWH CAN network, the network will shut down. The leveling system and all room extensions will not operate. If the ignition is off, no indicator lights will come on. If the ignition is in the "ON" or "ACC" position, the lighted reset switch and the MASTER WARNING Light will come on.

If the lighted reset switch is on, the switch must be pushed before any room or the leveling system can be operated.

A network problem with one room will not inhibit the use of the other rooms or leveling system after the reset switch is pushed.

A network problem with the leveling system will not inhibit the use of the room extensions after the reset switch is pushed.

If the lighted reset switch will not go out when pushed, there is a problem with the central control module of the network system. No rooms or the Leveling System will operate.

OPERATING PROCEDURES

PREPARATION FOR TRAVEL

Before traveling the red jack warning lights must be off and the "TRAVEL MODE" light must be on. If lights are not correct for travel, retract jack as described in the JACK RETRACTION section.

CAUTION: DO NOT RELY SOLELY UPON THE WARNING LIGHTS. IT IS THE OPERATOR'S RESPONSIBILITY TO CHECK THAT ALL JACKS ARE IN THE STORE/TRAVEL POSITION AND THAT THE ROOM EXTENSION IS FULLY RETRACTED BEFORE TRAVELING.

If the jacks and room extension are fully retracted but a red WARNING light is lit or the green "TRAVEL MODE" light is not lit, the system needs to be serviced.

NOTE: An extended jack can turn the green "TRAVEL MODE" light off and turn the MASTER WARNING light on.

If the jacks cannot be retracted according to the JACK RETRACTION section, retract the jacks according to the MANUAL JACK RETRACTION section. The system should then be checked.

AUTOMATIC HYDRAULIC LEVELING

1. Place the transmission in the recommended position for parking the vehicle and set the parking brake. Turn the ignition to the "ACCESSORY" or "ON" position.
2. Press the "I" button to enter the hydraulic operation mode. The LEVELING SYSTEM ACTIVE light will glow steady.

NOTE: The operator may want to check the jacks at this time and place a pad under each jack if the ground will not support the vehicle.

3. Press the "I" button a third time. The LEVELING SYSTEM ACTIVE light will start to flash. The system will automatically extend the jacks according to lit yellow LEVELING LIGHTS to level the vehicle and then stabilize the vehicle by extending any remaining jacks until they touch the ground lifting the vehicle slightly. After the system has finished leveling and stabilizing, it will automatically shut off.

EXCESS SLOPE SITUATION: In the event that the jacks are unable to level the coach, the "EXCESS SLOPE" indicator light will come on. The pump will shut off. The system will shut off. The system will NOT stabilize the vehicle if the "EXCESS SLOPE" light comes on. Store the jacks according to the JACK RETRACTION section. Move the vehicle to a more level position or level the vehicle as close as possible according to the MANUAL HYDRAULIC OPERATION section.

NOTE: The room extension can not be extended if the "EXCESS SLOPE" light is on, but it can be retracted.

The "EXCESS SLOPE" light will be on whenever the network is active until the vehicle is leveled with all yellow LEVEL INDICATOR lights off.

4. Turn the vehicle ignition switch to the "OFF" position.

OPERATING PROCEDURES

ROOM EXTEND PROCEDURE

It is recommended that the vehicle is leveled before extending a room.

1. The park brake must be set for the room to be operated. If the "EXCESS SLOPE" light on the touch panel is on, the room cannot be extended.

CAUTION: KEEP PEOPLE AND OBSTRUCTIONS CLEAR OF ROOM WHEN OPERATING.

NOTE: Make sure there is adequate clearance to fully extend the room and that all storage doors are closed.

2. Insert the KEY into the KEY SWITCH on the room extension operator's panel and turn it to the "ON" position. The READY TO OPERATE light will flash. When the amber light is on steady the room can be operated.

NOTE: Anytime the KEY SWITCH is on, the room air seal will deflate.

NOTE: If the Leveling System is being operated, the room will not extend. If the room panel KEY SWITCH is on, the "READY TO OPERATE" light will flash while the Leveling System is being operated.

3. To extend the room push and hold the ROOM CONTROL SWITCH in the "EXTEND" position. The red PUMP ON light will come on. Hold the ROOM CONTROL SWITCH to "EXTEND" for approximately five seconds after the room is fully extended. This assures proper pressurization of the cylinders. The red "PUMP ON" light will go out when the ROOM CONTROL SWITCH is released.

NOTE: Under normal operation of the room, the direction of movement should not be reversed. If the movement of the room must be reversed, do not try to re-extend the room until the room has been fully retracted.

IMPORTANT: IF EITHER SIDE OF THE ROOM STOPS MOVING, RELEASE THE ROOM CONTROL SWITCH IMMEDIATELY. THE ROOM OPERATION WILL HALT. DO NOT FORCE THE ROOM. DO NOT REVERSE DIRECTION OF THE ROOM. BINDING OF ROOM CAN CAUSE ROOM DAMAGE. CONTACT HWH CORPORATION CUSTOMER SERVICE FOR ASSISTANCE.

NOTE: The READY TO OPERATE light will flash when the room control switch is pushed if the "EXCESS SLOPE" light on the Leveling System panel is ON. The room will not extend.

4. Turn the KEY SWITCH to the "OFF" position and remove the key. The READY TO OPERATE light will go out. The air seal will inflate.

NOTE: If the KEY SWITCH is left "ON" the air seal will not inflate and the Network will stay active and not power down.

OPERATING PROCEDURES

ROOM RETRACT PROCEDURE

CAUTION: KEEP PEOPLE AND OBSTRUCTIONS CLEAR OF ROOM WHEN OPERATING.

1. The park brake must be set for the room to be operated.

IMPORTANT: It is recommended to retract room extensions before retracting the jacks.

2. Insert the KEY into the KEY SWITCH on the room extension operator's panel and turn it to the "ON" position. The air seal will deflate. The READY TO OPERATE light will flash. When the amber light is on steady the room can be operated.

NOTE: If the Leveling System is being operated, the room will not retract. If the room panel KEY SWITCH is ON, the READY TO OPERATE light will flash while the Leveling System is being operated. If the leveling system is in "STORE" mode, the room can be operated.

3. To retract the room push and hold the ROOM CONTROL SWITCH in the "RETRACT" position. The red PUMP ON light will come on. Hold the ROOM CONTROL SWITCH to "RETRACT" for approximately five seconds after the room is fully retracted. This assures proper pressurization of the cylinders. The red "PUMP ON" light will go out when the ROOM CONTROL SWITCH is released.

NOTE: Under normal operation the direction of movement should not be reversed. If the movement of the room must be reversed, do not try to retract the room until the room has been fully extended.

IMPORTANT: IF EITHER SIDE OF THE ROOM STOPS MOVING, RELEASE THE ROOM CONTROL SWITCH IMMEDIATELY. THE ROOM OPERATION WILL HALT. DO NOT FORCE THE ROOM. DO NOT REVERSE DIRECTION OF THE ROOM. BINDING OF ROOM CAN CAUSE ROOM DAMAGE. CONTACT HWH CORPORATION CUSTOMER SERVICE FOR ASSISTANCE.

4. Turn the KEY SWITCH to the "OFF" position and remove the key. The READY TO OPERATE light will go out. The air seal will inflate.

NOTE: If the KEY SWITCH is left "ON" the air seal will not inflate and the Network will stay active and not power down.

IN THE EVENT OF THE FAILURE OF THE ROOM TO RETRACT, CONTACT HWH CORPORATION CUSTOMER SERVICE AT 1-800-321-3494 FOR ASSISTANCE.

OPERATING PROCEDURES

JACK RETRACTION

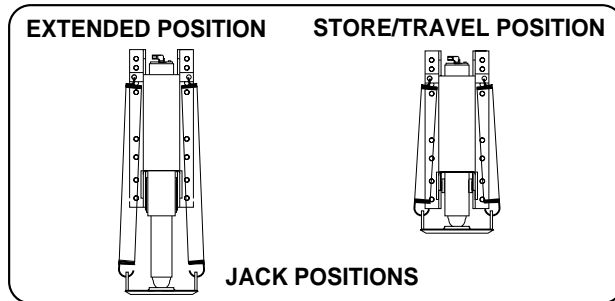

CAUTION: THE OPERATOR MUST BE SURE THAT THERE ARE NO OBJECTS UNDER THE VEHICLE AND THAT ALL PEOPLE ARE CLEAR OF THE VEHICLE.

1. Turn the ignition switch to "ON", "ACC", or start the engine. Press the "I" button one time. The "I" indicator light will glow steady.

2. Press the "STORE" button. The store indicator light will flash. As each jack retracts, its red WARNING light will go out. The vehicle can be moved as soon as the red WARNING lights are out and the green "TRAVEL" light is on, providing the jacks are in the STORE/TRAVEL position.

IMPORTANT: DO NOT interrupt power to the leveling system while the "STORE" indicator light is blinking. DO NOT push the "OFF" button. The system must be allowed to completely finish the store mode. If the engine was started before putting the system in the store mode, the vehicle may be moved when the jacks are in the STORE/TRAVEL position. This will not interrupt the store procedure.

CAUTION: DO NOT RELY SOLELY UPON THE WARNING LIGHTS. IT IS THE OPERATOR'S RESPONSIBILITY TO CHECK THAT ALL JACKS ARE IN THE STORE/TRAVEL POSITION BEFORE TRAVELING.

3. The system will automatically shut down six minutes after the four individual red "WARNING" lights are out. If any one red "WARNING" light does not go out, the system will continue to store for thirty (30) minutes, then shut down regardless of the "WARNING" lights condition.

NOTE: If the ROOM CONTROL SWITCH is pushed while the Leveling System is in the "STORE" mode, the STORE procedure is interrupted until the ROOM CONTROL SWITCH is released. If the four red WARNING lights are all out, the STORE light will continue to blink for six minutes, then the system will shut off.

4. If jacks cannot be retracted by the above procedure see MANUAL JACK RETRACTION Section.

MANUAL HYDRAULIC OPERATION

1. Place transmission in the recommended position for parking the vehicle, and set the parking brake. Turn the ignition to the "ACCESSORY" or "ON" position.

2. Press the "I" button. The indicator light will glow steady.

3. The vehicle may be leveled using the manual EXTEND buttons on the right half of the panel. If a yellow LEVEL SENSING light is on, that side or end of the vehicle is low. Jacks will extend (or retract) in pairs to raise (or lower) a side or end of the vehicle.

NOTE: As the jacks extend 1/4" to 1/2" the red warning light for the jack will come on.

Level the vehicle side to side, if necessary, before leveling the vehicle front to rear. Any jack not used for leveling can be extended to the ground. This provides additional stability against wind and activity in the vehicle.

IMPORTANT: Do not continue to push an EXTEND button for more than ten (10) seconds after that pair of jacks are fully extended.

4. When leveling is completed, push the "OFF" button on the leveling panel and turn the ignition switch to the "OFF" position.

OPERATING PROCEDURES

MANUAL JACK RETRACTION (4 Jack Systems with Valve Release Nuts)

NOTE: Use the Valve Release Nuts for retracting only if the "STORE" button on the control panel will not retract the jacks for travel.

CAUTION: KEEP AWAY FROM THE WHEELS, DO NOT CRAWL UNDER THE VEHICLE, KEEP A SAFE DISTANCE IN FRONT AND REAR OF THE VEHICLE. THE VEHICLE MAY DROP AND/OR MOVE FORWARD OR BACKWARD WITHOUT WARNING AS THE VALVE RELEASE IS OPERATED.

1. Locate the (4) valve release nuts on the solenoid valves. The solenoid valves are located on the power unit/valve assembly.
2. Allow clearance for the vehicle to lower.
3. Retract the front jacks by opening the two center valves. Slowly turn the valve release nuts counter clockwise using the 1/4" nut driver supplied.
4. Retract the rear jacks by opening the two outer valves. Slowly turn the valve release nuts counter clockwise using the 1/4" nut driver supplied.

IMPORTANT: Only open the valves enough to retract the jacks. DO NOT turn the release nuts more than 4 and 1/2 turns. Turning the nuts more could damage the valves.

NOTE: Prior to APRIL 2002 a 1/4" Nut Driver was sent with the Operators Manual. As of APRIL 2002 the 1/4" Nut Driver has been incorporated into the Breather Cap. See the back page of this manual for further info.

5. Check that all four jacks are now retracted.
6. Close the valves by turning the valve release nuts clockwise.

IMPORTANT: Once the valve release nuts are snug, DO NOT tighten the nuts past this point as internal damage may occur to the solenoid.

7. The system should now be repaired before using again.

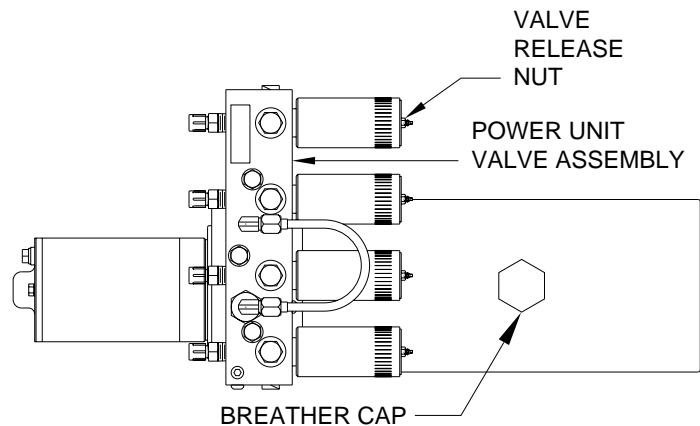

MAINTENANCE

OIL LEVEL

All maintenance should be done as part of the normal servicing of the coach.

The oil level should be checked when the vehicle is first purchased and then once every two years. More often if there is an oil leak in the system.

All four jacks and any HWH room extensions should be completely retracted before checking the oil level. The oil reservoir is part of the pump/manifold assembly. The oil level is checked and filled through the breather cap. Clear any dirt away from the breather/filler cap before removing. The oil level should be within one inch of the top of the reservoir. Most breather caps have a dipstick.

NOTE: Overfilling the tank can cause leakage of oil through the breather cap.

FLUID: HWH Specialty Hydraulic Oil is recommended. In an emergency Dexron automatic transmission fluid can be used. **NOTE:** Dexron automatic transmission fluid contains red dye and can cause staining should a leak occur. **DO NOT USE** brake fluid or hydraulic jack fluid. Use of these can damage seals.

ELECTRICAL SYSTEM

The batteries should be in good condition and fully charged. Weak batteries can cause erratic operation. Battery cable terminals and battery posts and connections should be kept clean.

All electrical connections, especially ground connections, should be clean, tight, free from corrosion and protected from weathering.

LEVELING JACKS

There are very few user serviceable parts on the leveling jacks. The jacks require very little maintenance. If the jacks are extremely dirty with caked on mud they should be washed.

The jack rods should NOT be wiped and do not need to be oiled or sprayed with anything.

ROOM EXTENSIONS

The HWH room mechanisms need no maintenance. DO NOT grease or lubricate any parts of the HWH mechanism.

Any visible mechanism can be kept clean by washing with water. Refer to the vehicle manufacturer for correct maintenance of the room seals.

VISUAL INSPECTION

Periodically inspect the leveling system for oil leaks and damaged or missing parts, such as pivot bolts or springs. Check the hydraulic lines and wiring for damage and wear. Check that the jacks do not interfere with any parts of the vehicle when they are in the "STORE" position.

The jacks should be cycled at least once a month or whenever the coach is serviced. The system will operate better if kept clean and free from caked on mud or ice.

OPERATIONAL CHECK

Review the OPERATOR MANUAL. Run the system according to the SYSTEM OPERATION (LEVELING) Section. Note any abnormal operation.

Review the "JACK RETRACTION" Section. Make sure the jacks will fully retract to the "STORE" position. Jacks should not interfere with any of the coach when in the "STORE" position.

Check that all lights work according to the "INDICATOR LIGHT" Section. Correct function of the red "WARNING" light is important.

MAINTENANCE

NOT IN PARK/BRAKE CHECK

CAUTION: WHEN MAKING THIS CHECK, BLOCK THE COACH WHEELS SECURELY SO THE COACH CANNOT ROLL FORWARD OR BACKWARD.

Set the park/brake. Switch the ignition to the "ACC" or "ON" position. Push the "ON/OFF" switch toward "ON". Release the parking brake and confirm that the "PARK" indicator light comes on. Reset the parking brake. The "PARK" indicator light should go out. Switch the ignition to "OFF".

If any of the above checks or inspections reveal a problem or if there are other problems or questions, consult a qualified RV repair center, your vehicle or coach manufacturer, or HWH CORPORATION for service or repair.

SENSING UNIT ADJUSTMENT

Level the vehicle by placing a bubble level in the center of the freezer floor or upon whichever surface within the vehicle that is to be level. Using the Leveling System and the bubble level, ignoring the yellow LEVEL lights on the Touch Panel, level the vehicle until the bubble is centered.

With the vehicle level according to the bubble level, if there are no yellow lights lit on the Touch Panel, the sensing unit is properly adjusted. If there are yellow LEVEL lights lit on the Touch Panel, manual adjustments to the Sensing Unit are needed. A 7/8", 3/4" or 5/16" socket w/driver or box end wrench and a philips screw driver will be needed.

The Sensing Unit is mounted inside the Control Box. The Control Box is mounted to the power unit/valve assembly.

There are four LED's on the Sensing Unit, A,B,C and D. Refer to the drawing below. The Sensing Unit is adjusted by turning the adjustment nut to turn out LED's B and D. The adjustment screw will turn out LED's A and C. If the adjustment nut has to be turned more than 1/2 flat or the adjustment screw has to be turned more than 3/4 turn to turn the LED out, there may be a problem with the Sensing Unit or the mounting of the Control Box. If two LED's are on, it is best to make the B-D adjustments first, then hold the adjustment nut from moving while making the A-C adjustment.

NOTE: If opposing LED's are lit, there is a problem with the Sensing Unit.

If LED (A) is lit: Turn the adjustment screw COUNTER CLOCKWISE until the LED is off.

If LED (C) is lit: Turn the adjustment screw COUNTER CLOCKWISE until the LED is off.

If LED (B) is lit: Turn the adjustment nut COUNTER CLOCKWISE until the LED is off.

If LED (D) is lit: Turn the adjustment nut COUNTER CLOCKWISE until the LED is off.

When all 4 LED's are off, move the vehicle to an unlevel vehicle position so one or two yellow lights are on. Level the vehicle according to the yellow LEVEL lights. Recheck the level. Readjust as necessary. Repeat this until the vehicle can be leveled using the yellow LEVEL lights.

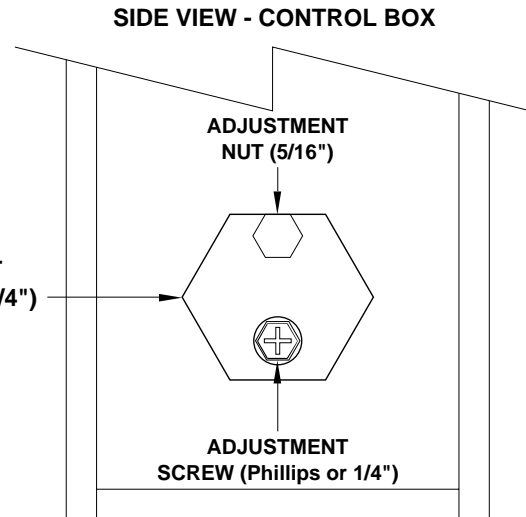
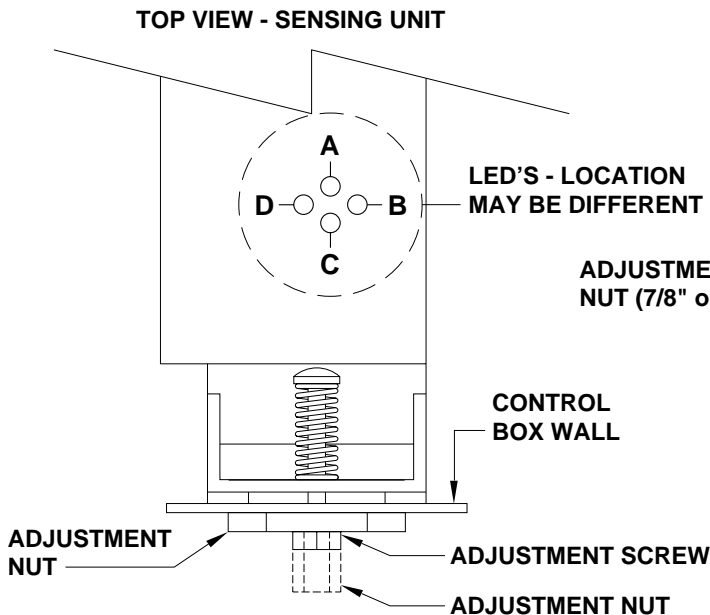

BREATHER CAP - DIPSTICK - 1/4" NUT DRIVER

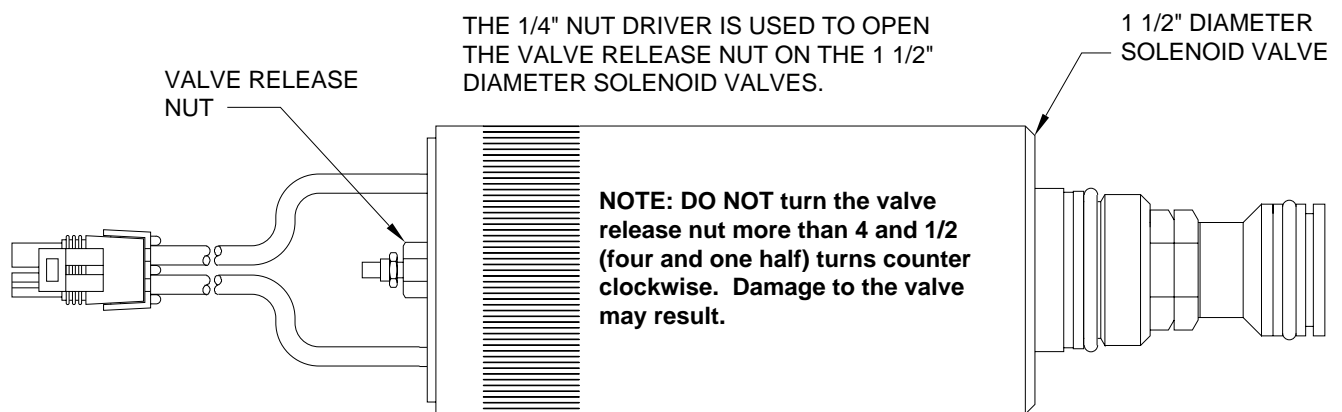

NOTE: THE BREATHER CAP IS LOCATED ON THE TOP SIDE OF THE POWER UNIT RESERVOIR.

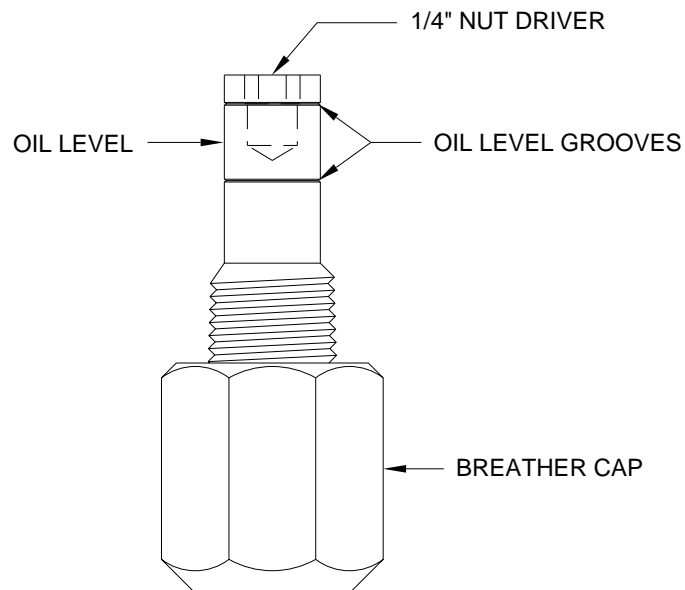

IMPORTANT: PRIOR TO REMOVING THE BREATHER CAP, EITHER TO CHECK THE OIL LEVEL OR TO USE THE 1/4" NUT DRIVER, CLEAN ANY DEBRIS FROM THE TOP OF THE RESERVOIR. BEFORE RETURNING THE BREATHER CAP TO THE RESERVOIR, REMOVE ANY PAINT CHIPS OR OTHER DEBRIS FROM THE DIPSTICK INCLUDING DEBRIS INSIDE THE 1/4" NUT DRIVER.