



OPERATOR'S MANUAL

HWH® HYDRAULIC LANDING GEAR SYSTEM AND SPACEMAKER® ROOM EXTENSION SYSTEMS

FEATURING:

*Lever Control Auxiliary Hand Pump
Two Double-Acting Jacks
One Universal Slide Out*

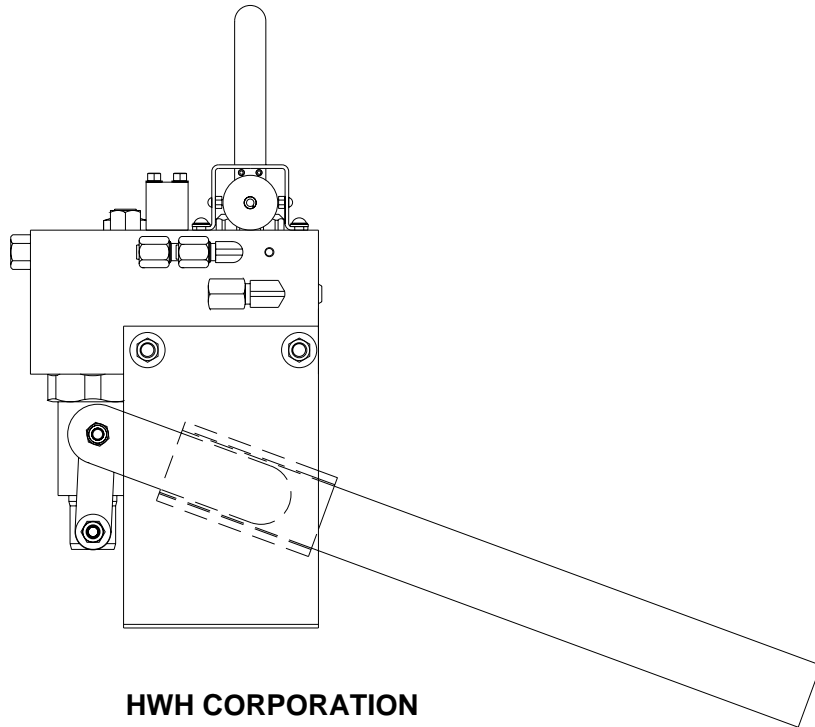

HWH CORPORATION

(On I-80, Exit 267 South)

2096 Moscow Road | Moscow, Iowa 52760

Ph: 800/321-3494 (or) 563/724-3396 | Fax: 563/724-3408

www.hwh.com

OPERATOR'S MANUAL

WARNING !

READ ENTIRE HWH AND VEHICLE OPERATOR'S MANUALS BEFORE OPERATING.

JACKS UNDER LOAD WILL RETRACT WHEN LEVER IS MOVED TO RETRACT POSITION WITHOUT THE PUMP RUNNING.

CHOCK TRAILER WHEELS SECURELY BEFORE USING THE LANDING GEAR.

DO NOT LIFT THE TOW VEHICLE WITH THE LANDING GEAR.

BLOCK FRAME AND TIRES SECURELY BEFORE CRAWLING UNDER THE TRAILER, CHANGING TIRES, OR ENTERING AREAS WHERE BODY MAY BE CRUSHED BY SUDDEN DROPPING OR SLIDING OF TRAILER.

THE TRAILER MAY DROP AND/OR MOVE FORWARD OR BACKWARD WITHOUT WARNING CAUSING INJURY OR DEATH.

NEVER PLACE HANDS OR OTHER PARTS OF THE BODY NEAR HYDRAULIC LEAKS. OIL MAY PENETRATE SKIN CAUSING INJURY OR DEATH.

WEAR SAFETY GLASSES WHEN INSPECTING OR SERVICING THE SYSTEM TO PROTECT EYES FROM DIRT, METAL CHIPS, OIL LEAKS, ETC. FOLLOW ALL OTHER APPLICABLE SHOP SAFETY PRACTICES.

IMPORTANT: IF COACH IS EQUIPPED WITH A ROOM EXTENSION, READ ROOM EXTENSION SECTION BEFORE OPERATING LEVELING SYSTEM.

HOW TO OBTAIN WARRANTY SERVICE

THIS IS NOT TO BE INTERPRETED AS A STATEMENT OF WARRANTY

HWH CORPORATION strives to maintain the highest level of customer satisfaction. Therefore, if you discover a defect or problem, please do the following:

FIRST: Notify the dealership where you purchased the vehicle or had the leveling system installed. Dealership management people are in the best position to resolve the problem quickly. If the dealer has difficulty solving the problem, he should immediately contact the Customer Service Department, at HWH CORPORATION.

SECOND: If your dealer cannot or will not solve the problem, notify the Customer Service Department:
HWH CORPORATION 2096 Moscow Rd. Moscow IA. 52760
(563) 724-3396 OR (800) 321-3494. Give your name and address, coach manufacturer and model year, date the coach was purchased, or the date of system installation,

description of the problem, and where you can be reached during business hours (8:00 a.m. till 5:00 p.m. c.s.t.). HWH CORPORATION personnel will contact you to determine whether or not your claim is valid. If it is, HWH CORPORATION will authorize repair or replacement of the defective part, either by appointment at the factory or by the authorization of an independent service facility, to be determined by HWH CORPORATION. All warranty repairs must be performed by an independent service facility authorized by HWH CORPORATION, or at the HWH CORPORATION factory, unless prior written approval has been obtained from proper HWH CORPORATION personnel.

CONTROL IDENTIFICATION

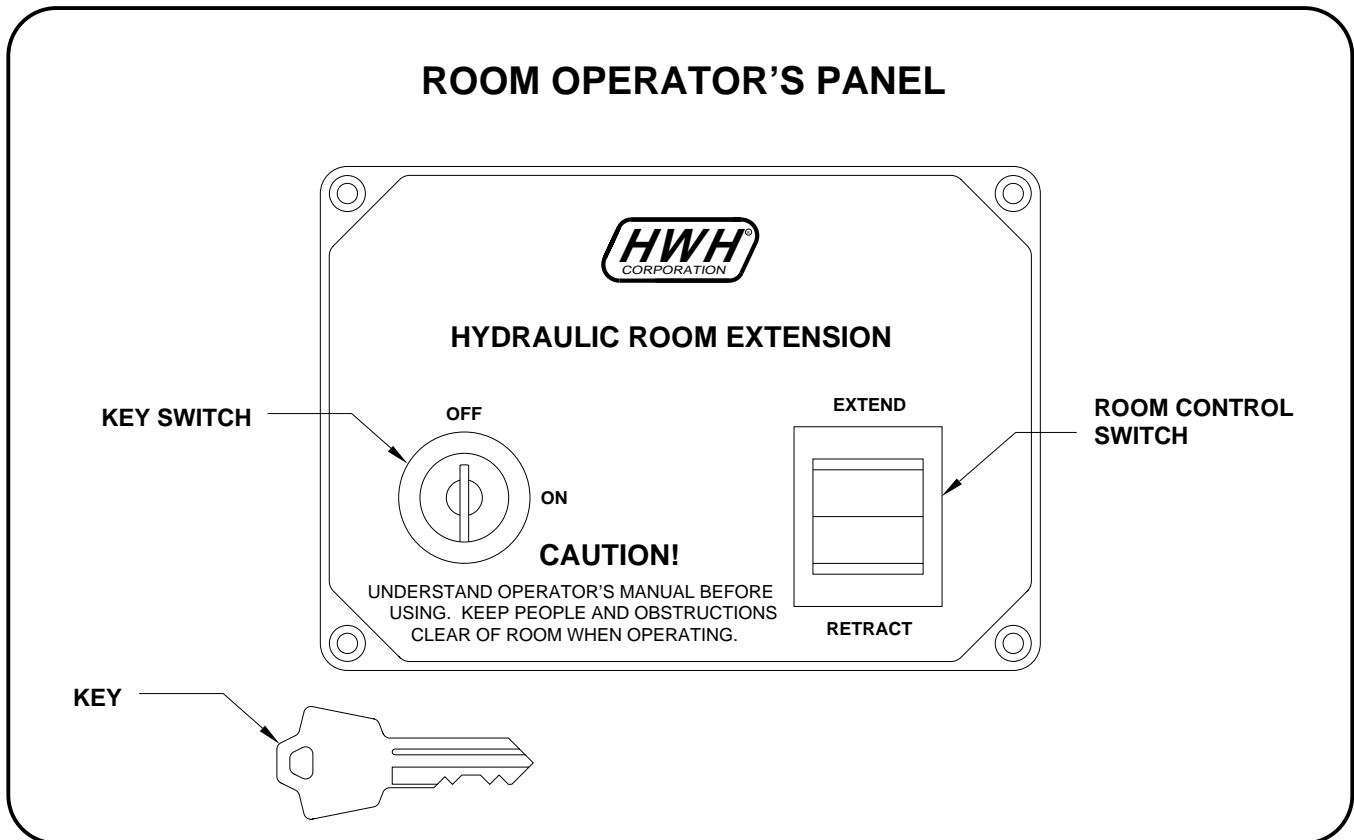

CONTROL FUNCTIONS

KEY SWITCH: The KEY SWITCH controls power to the ROOM CONTROL SWITCH. When the KEY SWITCH is in the "ON" POSITION the room can be operated, and the key cannot be removed. When the KEY SWITCH is in the "OFF" position the room cannot be operated, and the key can be removed.

ROOM CONTROL SWITCH: The ROOM CONTROL SWITCH is a two position momentary switch. Pressing the switch in the EXTEND POSITION will extend the room. Pressing the switch in the RETRACT POSITION will retract the room. Releasing the ROOM CONTROL SWITCH will halt the operation of the room.

OEM PROVIDED ROOM SELECTOR SWITCH (IF APPLICABLE)

ROOM SELECTOR SWITCH: This switch (not shown) is OEM provided. Refer to OEM operator instructions.

CONTROL IDENTIFICATION

LANDING GEAR VALVE WITH AUXILIARY PUMP

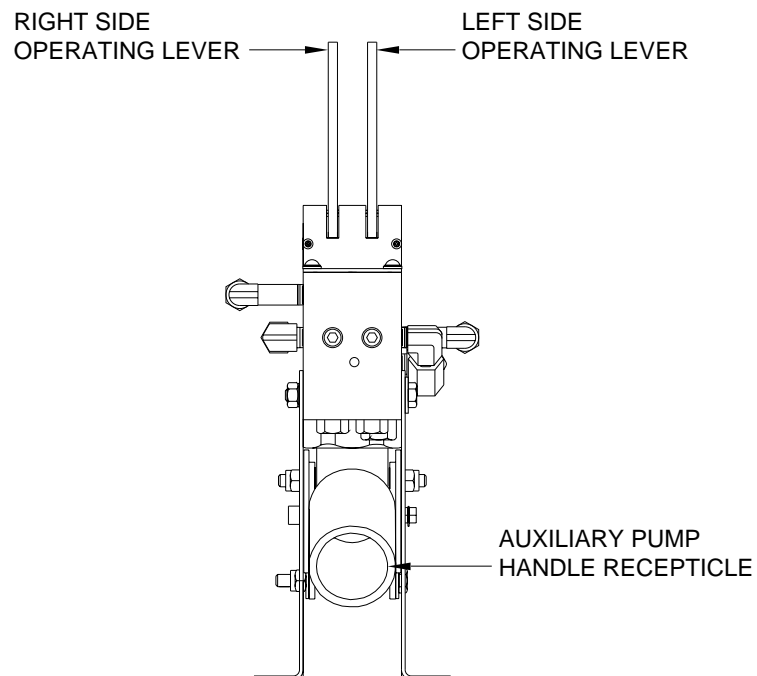
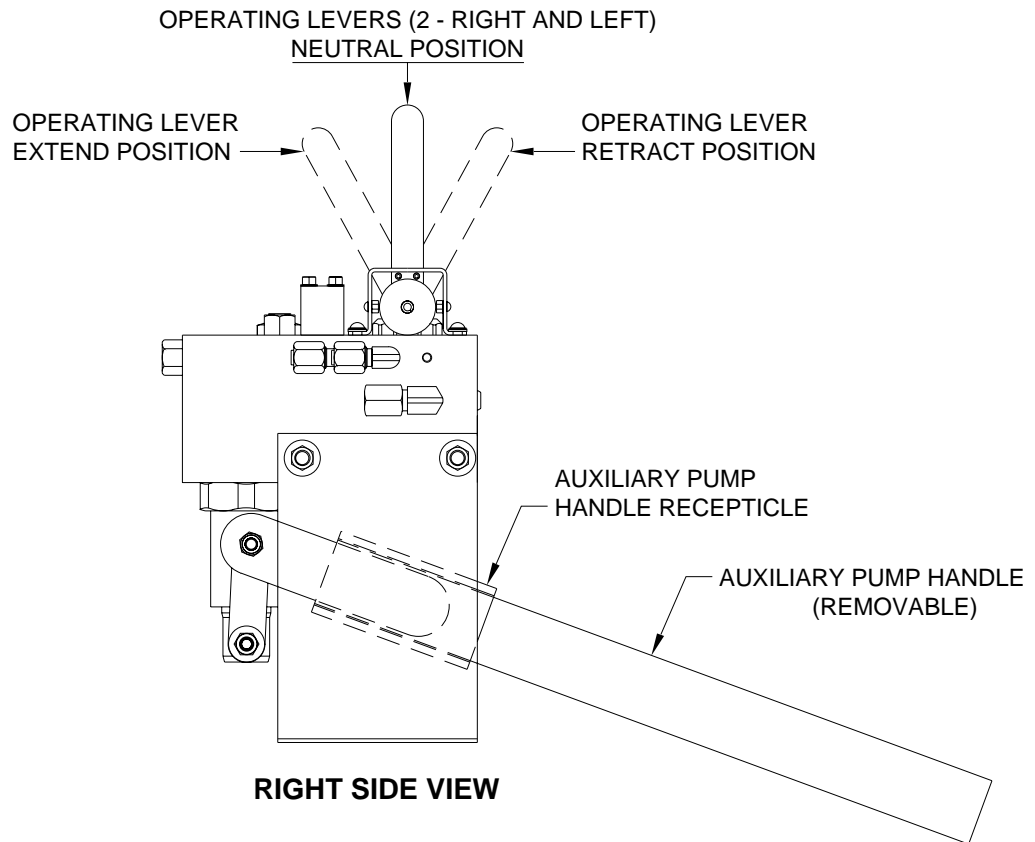

OPERATING PROCEDURES

GENERAL INSTRUCTIONS

Maintain adequate clearance in all directions for vehicle, room extensions, awnings, doors, steps, etc. Vehicle may move in any direction due to landing gear extending or retracting, settling of the landing gear or the vehicle, equipment malfunction, etc..

If parking on soft ground or asphalt paving, wood blocks or pads must be placed under the jacks.

The landing gear system should be cycled once a month or whenever the vehicle is used, to keep the system in operating condition.

WARNING: DO NOT MOVE THE VEHICLE IF ONE OR MORE LANDING GEAR ARE EXTENDED TO THE GROUND.

PREPARATION FOR TRAVEL

When the landing gear are completely stored or the trailer is supported on the landing gear, the operating levers should be in the neutral position.

Any room extension should be fully retracted before traveling.

WARNING: DO NOT MOVE THE VEHICLE WHILE THE LANDING GEAR JACKS ARE STILL IN CONTACT WITH THE GROUND OR IN THE EXTENDED POSITION. THIS VEHICLE IS EQUIPPED WITH STRAIGHT- ACTING LANDING GEAR JACKS. MOVING THE VEHICLE WITH

THE LANDING GEAR JACKS EXTENDED CAN CAUSE SEVERE DAMAGE TO THE LANDING GEAR JACKS AND OR THE VEHICLE AND CREATE A DRIVING HAZARD. IT IS THE OPERATOR'S RESPONSIBILITY TO CHECK THAT ALL LANDING GEAR JACKS ARE FULLY RETRACTED INTO THE STORE/TRAVEL POSITION.

If the landing gear jacks cannot be extended or retracted according to the SET UP or PREPARATION FOR TRAVEL procedures, refer to the AUXILIARY HAND PUMP procedures.

ROOM EXTENSION PROCEDURES

IMPORTANT: If the vehicle is equipped with a room extension read this section carefully.

IMPORTANT: It is recommended to level and stabilize the vehicle before extending the room.

IMPORTANT: Extending or retracting any leveling jacks or landing gear when the room is extended is not recommended.

Refer to the vehicle owner's manual for proper operation of room extensions.

IMPORTANT: Do not use a room extension support when the vehicle is supported by the landing gear system.

OPERATING PROCEDURES

SET UP PROCEDURE

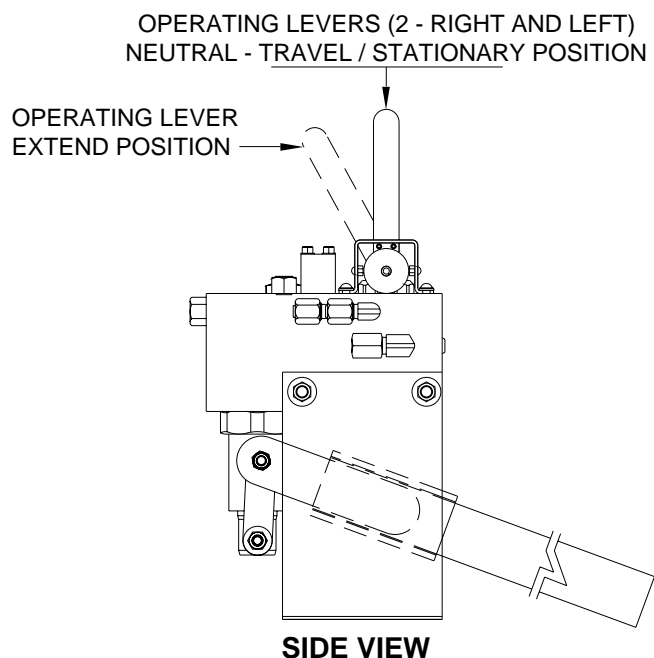

WARNING: DO NOT STAND BETWEEN THE TOW VEHICLE AND THE TRAILER OR BEHIND THE TRAILER WHEN UNHITCHING THE TRAILER OR OPERATING THE HWH LANDING GEAR.

If parking on soft ground or asphalt paving, wood blocks or pads must be placed under the jacks.

NOTE: There is an operating lever for each landing gear jack. Each can be operated individually by moving one lever only. IT IS RECOMMENDED TO OPERATE BOTH JACKS AT THE SAME TIME WHEN UNHITCHING, LIFTING OR SUPPORTING THE TRAILER WITH THE LANDING GEAR.

1. Refer to the trailer manufacturer for instructions on unhitching the trailer from the tow vehicle.

2. Move the operating levers to the "EXTEND" position.
3. Push and hold the pump operating button.
4. When the landing gear and trailer are in the desired position, release the pump operating button.
5. Return the operating levers to the "NEUTRAL" position.

IMPORTANT: KEEP THE OPERATING LEVERS IN THE "NEUTRAL" POSITION WHEN THE TRAILER IS SUPPORTED ON THE LANDING GEAR.

In the case of a power failure or pump failure, the landing gear can be extended to hitch or unhitch the trailer. See "AUXILIARY HAND PUMP" operating procedures.

OPERATING PROCEDURES

PREPARATION FOR TRAVEL

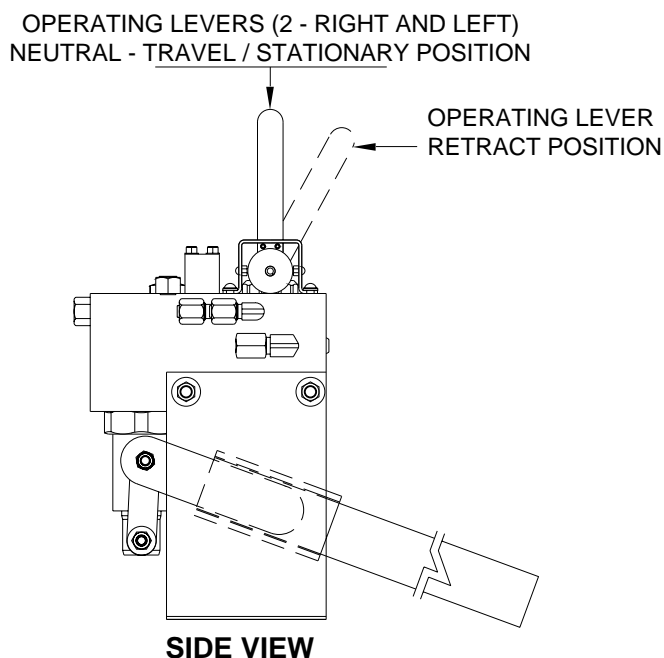

WARNING: DO NOT STAND BETWEEN THE TOW VEHICLE AND THE TRAILER OR BEHIND THE TRAILER WHEN UNHITCHING THE TRAILER OR OPERATING THE HWH LANDING GEAR.

The trailer can be hitched to the tow vehicle using the operating levers without running the pump. By slowly pulling the levers to the "RETRACT" position, the weight of the trailer can be lowered onto the tow vehicle.

1. Hitch the trailer to the tow vehicle according to the trailer manufacturer's instructions. DO NOT pull the levers to the full retract detent (lock) position until the trailer is securely hitched to the tow vehicle.

WARNING: THE TRAILER SHOULD BE SECURELY HITCHED TO THE TOW VEHICLE BEFORE MOVING THE OPERATING LEVERS TO THE FULLY LOCKED "RETRACT" POSITION.

NOTE: It is recommended to pull both levers at the same time while lowering the trailer. This will reduce twisting of the trailer.

2. When the trailer is securely hitched to the tow vehicle, pull the levers to the full "RETRACT" position. They should lock in place.

3. Push and hold the pump operation button until the jacks have retracted to the full store position.

4. Release the pump operating button and move the levers to the "NEUTRAL" position for traveling.

NOTE: Do Not hold the pump operating button for more than 10 seconds after the jacks are fully retracted.

WARNING: DO NOT MOVE THE VEHICLE WHILE THE LANDING GEAR JACKS ARE STILL IN CONTACT WITH THE GROUND OR IN THE EXTENDED POSITION. THIS VEHICLE IS EQUIPPED WITH STRAIGHT- ACTING LANDING GEAR JACKS. MOVING THE VEHICLE WITH THE LANDING GEAR JACKS EXTENDED CAN CAUSE SEVERE DAMAGE TO THE LANDING GEAR JACKS AND OR THE VEHICLE AND CREATE A DRIVING HAZARD. IT IS THE OPERATOR'S RESPONSIBILITY TO CHECK THAT ALL LANDING GEAR JACKS ARE FULLY RETRACTED INTO THE STORE/TRAVEL POSITION.

If the landing gear jacks cannot be extended or retracted to PREPARATION FOR TRAVEL procedures, refer to the "AUXILIARY HAND PUMP" procedures in this manual.

OPERATING PROCEDURES

AUXILIARY HAND PUMP OPERATION

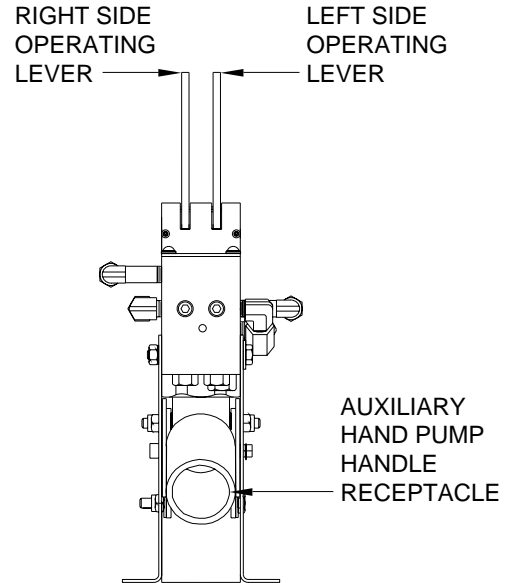
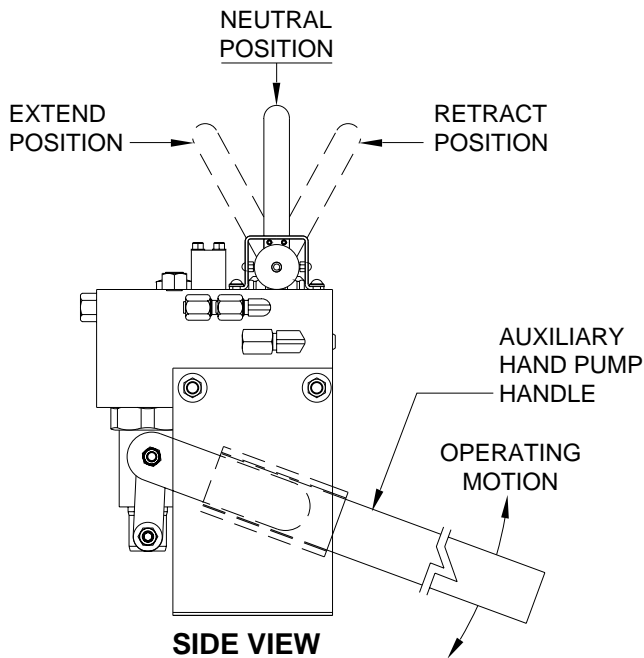

The auxiliary hand pump can be used to extend or retract the landing gear anytime the pump will not function.

The auxiliary hand pump is a two stage pump that will produce enough pressure to extend the landing gear and lift the trailer as well as retract the landing gear. When operating the auxiliary pump to lift the trailer or when the jacks are fully retracted, the pump handle will seem to "snap" as the pump goes to the second stage. The pumping action will be easier at first as the second stage starts to create more pressure.

To operate the auxiliary hand pump, move the operating handles to the desired position. Insert the hand pump handle into the handle receptacle and move the handle in an up and down motion.

WARNING: THE TRAILER SHOULD BE SUPPORTED BY AUXILIARY STANDS OR SECURELY HITCHED TO THE TOW VEHICLE BEFORE MOVING THE OPERATING LEVERS TO THE FULLY LOCKED "RETRACT" POSITION.

The auxiliary hand pump may work easier if only one one operating lever is used at a time. **Be careful to not twist the trailer if only one handle is in the EXTEND or RETRACT position.**

IMPORTANT: FOLLOW THE "SET UP" AND "PREPARATION FOR TRAVEL" PROCEDURES WHEN USING THE AUXILIARY HAND PUMP.

It is recommended to operate the auxiliary hand pump occasionally to check it's operation.

OPERATING PROCEDURES

ROOM EXTEND PROCEDURE FOR ROOMS WITHOUT TRAVEL CLAMPS

WARNING: OPERATING A ROOM WITH ANY ROOM LOCKING, CLAMPING OR MANUAL RETRACTING DEVICES ATTACHED OR ENGAGED CAN CAUSE PERSONAL INJURY AND VEHICLE DAMAGE. IT IS THE OPERATOR'S RESPONSIBILITY TO ENSURE THAT ALL ROOM LOCKING, CLAMPING OR MANUAL RETRACTING DEVICES ARE DETACHED OR DISENGAGED BEFORE OPERATING THE ROOM.

NOTE: It is recommended to complete any applicable Leveling Procedure before operating room extensions. It is recommended to retract room extensions before retracting a leveling system.

1. The park brake must be set for motorized vehicles. The room will not operate if the park brake is not set.
2. Follow applicable LEVELING AND STABILIZING PROCEDURES.
3. Unlock all room-locking devices to include travel clamps/locks supplied by manufacturers other than HWH.

NOTE: If the MANUAL RETRACT WINCH is attached to the room remove it before extending the room.

WARNING: KEEP PEOPLE AND OBSTRUCTIONS CLEAR OF ROOM WHEN OPERATING.

NOTE: Make sure there is adequate clearance to fully extend the room.

4. Turn the ignition switch to ACCESSORY or turn a MASTER POWER SWITCH on, if applicable.
5. Turn the room control panel KEY SWITCH to the "ON" position.

6. To extend the room, press and hold the ROOM CONTROL SWITCH in the "EXTEND" position until the room is fully extended.

NOTE: Hold the switch to "EXTEND" three or four seconds after the room is fully extended. This assures proper pressurization of the cylinders. **During normal operation of the room, do not reverse direction of the room until the room is fully extended. If necessary, the direction of the room may be reversed, but watch for binding of the room. If the direction of the room has been reversed, DO NOT re-extend the room until the room has been fully retracted.**

IMPORTANT: Do not hold the ROOM CONTROL SWITCH in the "EXTEND" position for more than ten seconds after the room is fully extended or stops moving. **If either side of the room stops moving, release the room control switch immediately. DO NOT force the room. DO NOT reverse direction of the room, contact HWH Customer Service for assistance 1-800-321-3494.**

NOTE: Releasing the ROOM CONTROL SWITCH will halt the operation of the room.

7. Turn the room control panel KEY SWITCH to the "OFF" position.
8. Turn off the ignition switch, if applicable.

IMPORTANT: Do not use a room extension support when the vehicle is supported by the leveling system.

OPERATING PROCEDURES

ROOM RETRACT PROCEDURE FOR ROOMS WITHOUT TRAVEL CLAMPS

WARNING: KEEP PEOPLE AND OBSTRUCTIONS CLEAR OF ROOM WHEN OPERATING.

NOTE: It is recommended to retract room extensions before retracting a leveling system.

1. The park brake must be set, if applicable. The room will not operate if the park brake is not set.
2. Turn the ignition switch to ACCESSORY or turn a MASTER POWER SWITCH on, if applicable.
3. Turn the room control panel KEY SWITCH to the "ON" position.
4. To retract the room press and hold the ROOM CONTROL SWITCH in the "RETRACT" position until the room is fully retracted.

NOTE: Hold the switch to "RETRACT" three or four seconds after the room is fully retracted. This assures proper pressurization of the cylinders. **During normal operation of the room, do not reverse direction of the room until the room is fully retracted. If necessary, the direction of the room may be reversed, but watch for binding of the room. If the direction of the room has been reversed, DO NOT retract the room until the room has been fully extended.**

IMPORTANT: Do not hold the ROOM CONTROL SWITCH in the "RETRACT" position for more than ten seconds after the room is fully retracted or stops moving.

If either side of the room stops moving, release the room control switch immediately. DO NOT force the room. DO NOT reverse direction of the room, contact HWH Customer Service for assistance 1-800-321-3494.

NOTE: Releasing the ROOM CONTROL SWITCH will halt the operation of the room.

5. Turn the room control panel KEY SWITCH to the "OFF" position.
6. Turn the ignition switch off, if applicable.
7. If the room will not retract see the MANUAL ROOM RETRACT PROCEDURE.

IMPORTANT: Room-locking devices should be locked while traveling.

OPERATING PROCEDURES

"UNIVERSAL STRAIGHT OUT" ROOM EXTENSION MECHANISM

MANUAL ROOM RETRACTION PROCEDURES

1. Determine which extend and retract solenoid valves are assigned to the room. Manually open the valve release nuts for the extend and retract solenoid valves by turning the 1/4" release nuts counter clockwise 4 and 1/2 turns. Turning the nuts more could damage the valves.

NOTE: The breather cap dip stick is also a 1/4" nut driver.

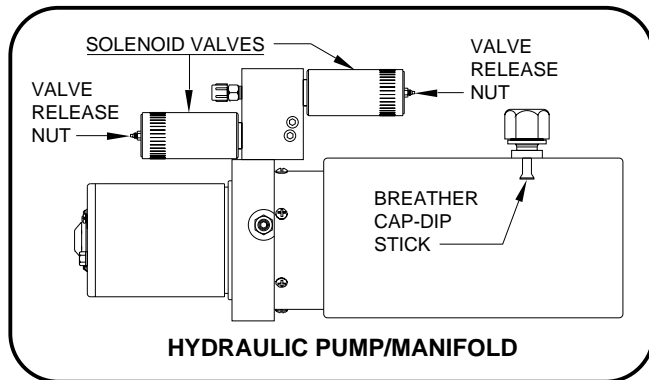

2. Start both threaded rods until resistance is met, one for the front and one for the rear mechanism should be provided.

NOTE: To access the threaded blocks refer to vehicle manufacturer.

3. **Do Not use an impact wrench.** Using wrench provided, a personal wrench or a tire iron with a 1-1/8" opening rotate either mechanism's threaded rod clockwise 6 complete turns.

4. Move to the other room extension mechanism, rotate the threaded rod clockwise 12 complete turns.

5. Return to the first room extension mechanism and rotate the threaded rod clockwise 12 complete turns.

6. Repeat steps 4 and 5 alternating from mechanism to mechanism rotating each threaded rod 12 complete turns until room is sealed. (DO NOT exceed 15 ft.lbs) Make sure the room does not bind.

IMPORTANT: If at any stage something is not understood or if the room begins to bind DO NOT force the room, contact HWH Customer Service for assistance 1-800-321-3494.

NOTE: Leave the solenoid valves open and the threaded rods in place until the room has been serviced.

IMPORTANT: DO NOT EXTEND THE ROOM UNTIL THE ROOM HAS BEEN SERVICED. ANY SOLENOID VALVES LEFT OPEN SHOULD BE CLOSED AND THE THREADED RODS SHOULD BE COMPLETELY REMOVED.

NOTE: If there is not enough room to remove both threaded rods completely, alternate backing the threaded rods out and slightly extending the room. Be careful to not extend the room so far that the threaded rods impact the coach wall or the mechanism.

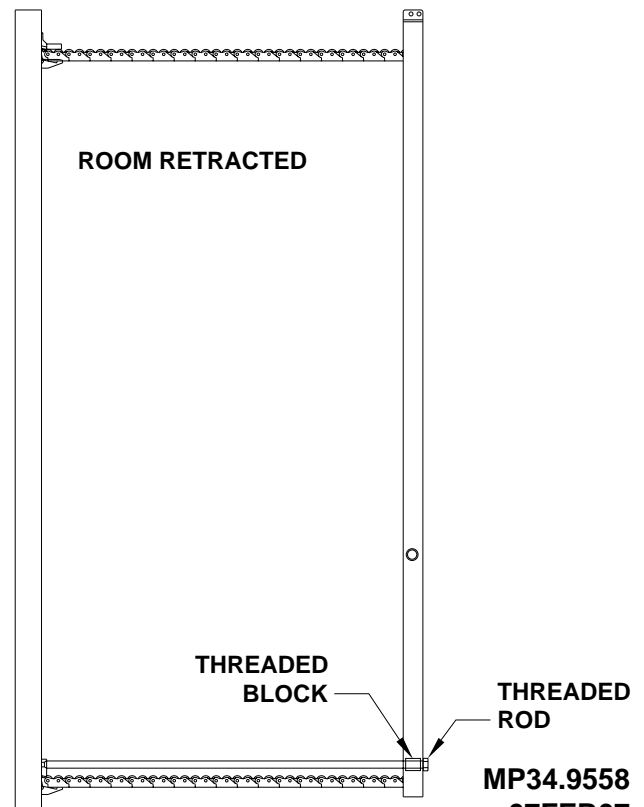
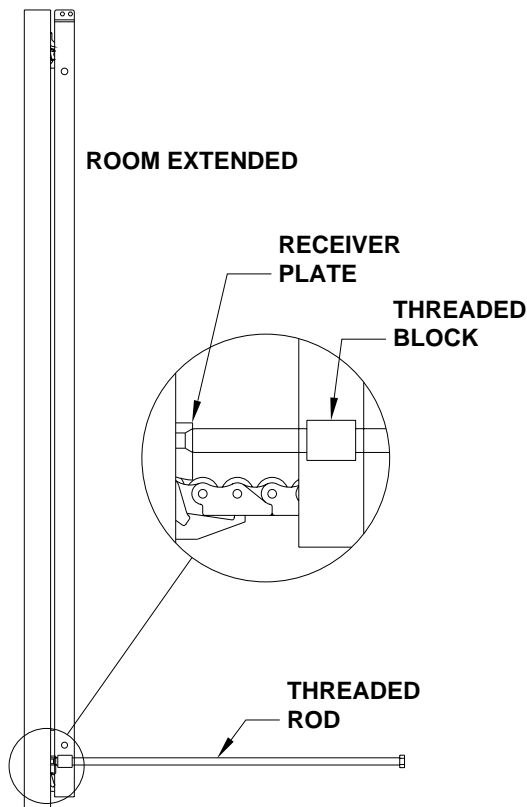

MP34.9558
07FEB07

HYDRAULIC CONNECTION DIAGRAM LANDING GEAR SYSTEM - HAND PUMP

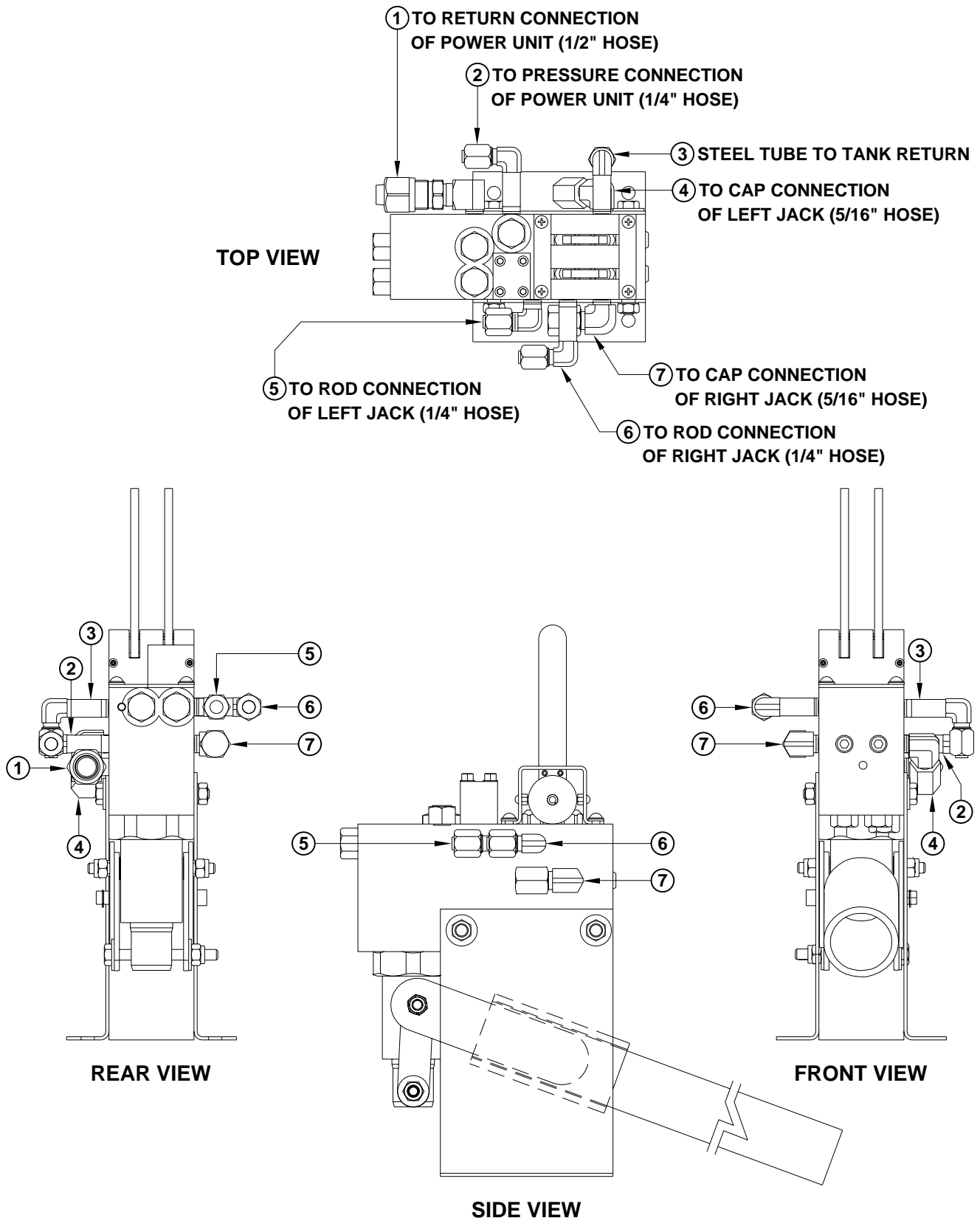

HYDRAULIC LINE CONNECTION DIAGRAM

LANDING GEAR SYSTEM - ONE ROOM EXTENSION

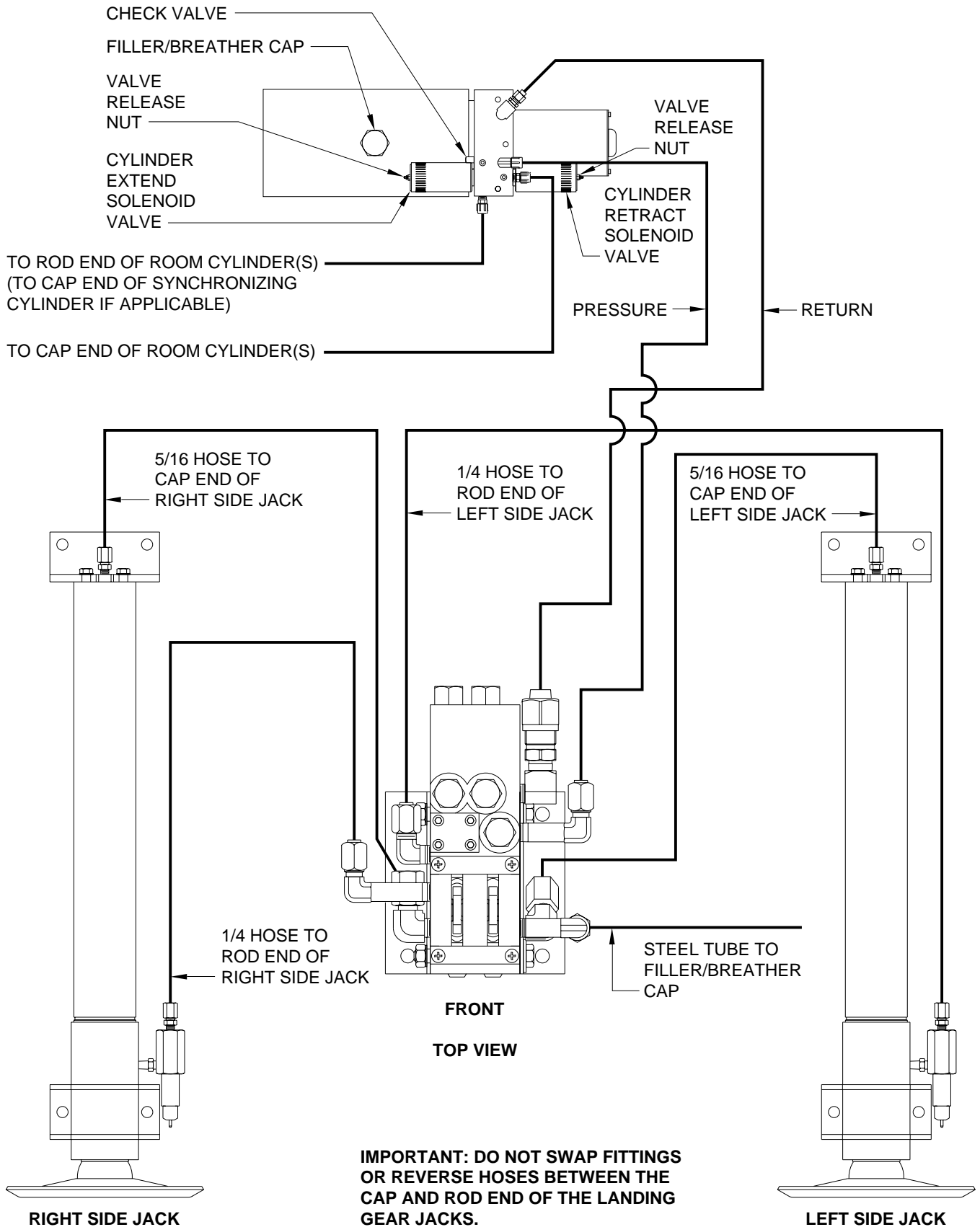

ELECTRICAL CONNECTION DIAGRAM ROOM EXTENSION SYSTEM

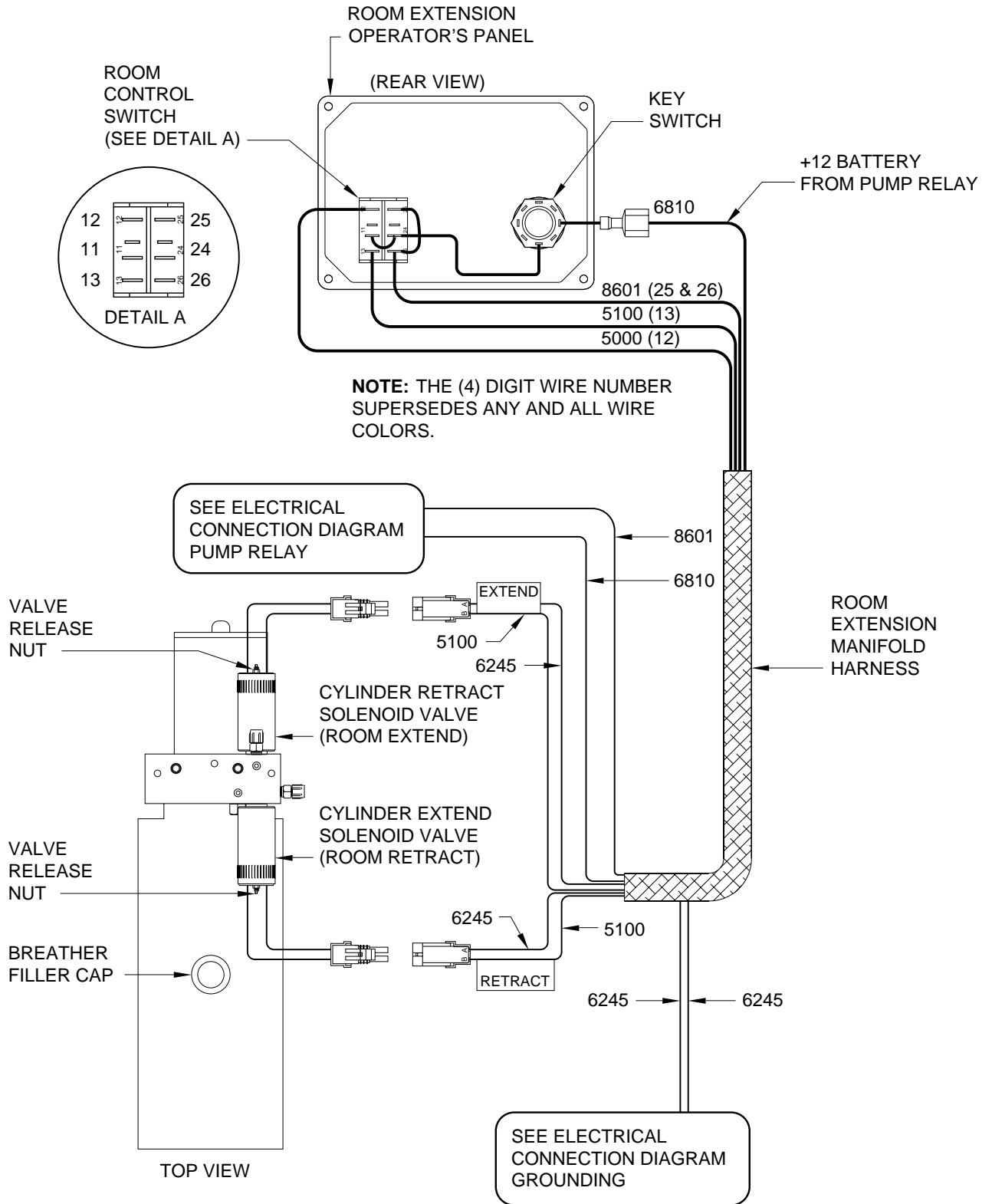

ELECTRICAL CONNECTION DIAGRAM

PUMP RELAY AND GROUNDING

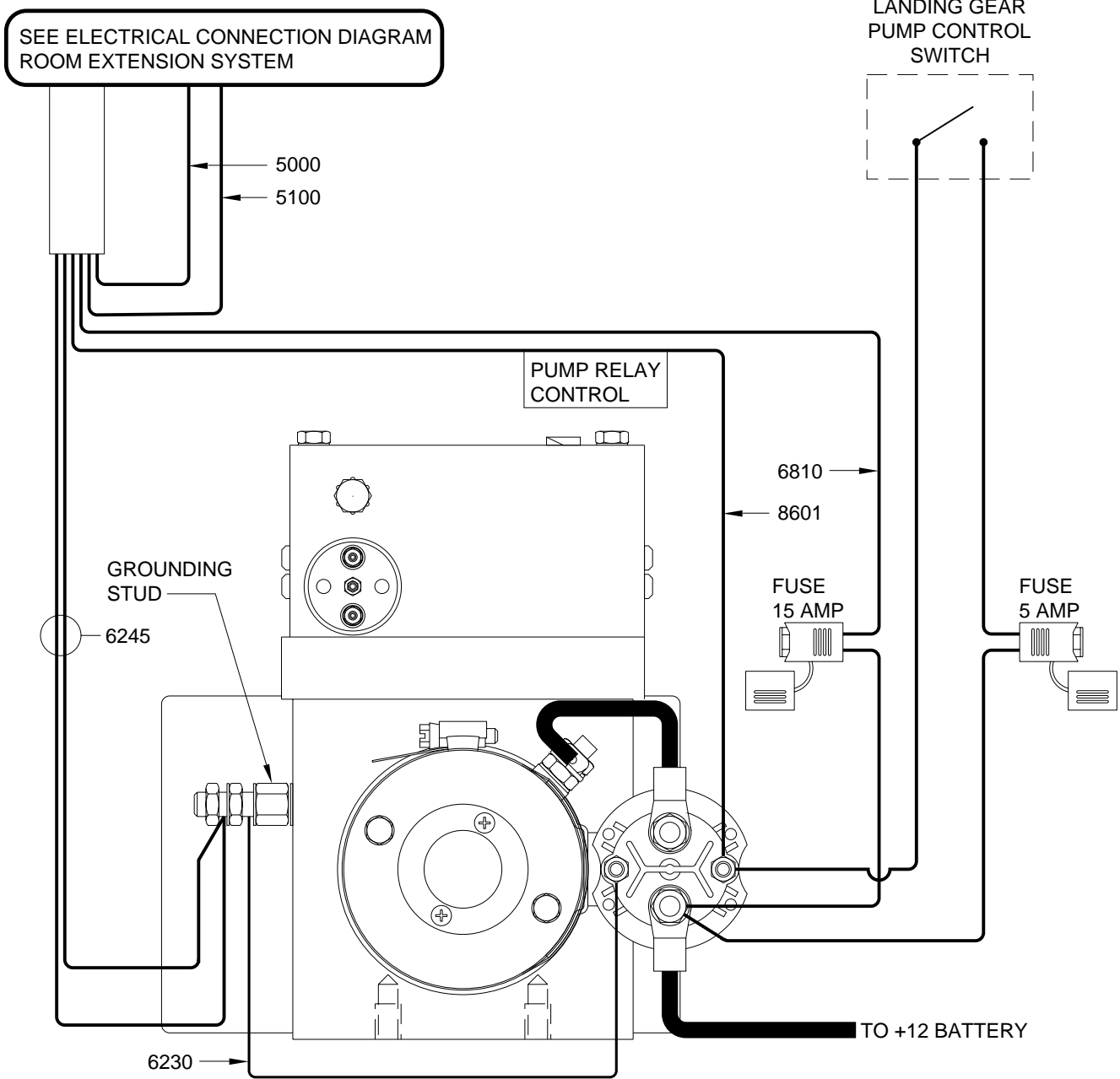

IMPORTANT: THE PUMP MUST HAVE A SOLID FRAME MOUNT OR A NUMBER 2 BATTERY CABLE SHOULD BE APPLIED FROM THE GROUNDING STUD TO THE FRAME TO SUPPLY AN AMPLE GROUND CONNECTION FOR THE PUMP MOTOR.

BREATHER CAP - DIPSTICK - 1/4" NUT DRIVER

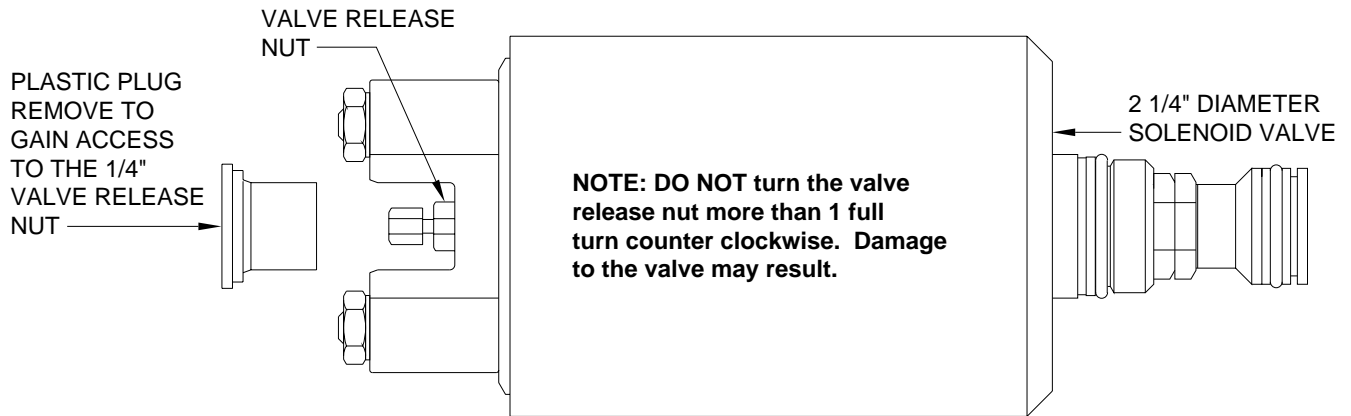
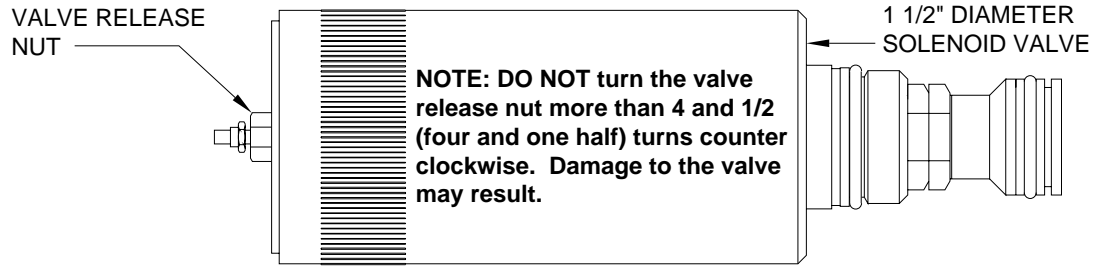

NOTE: THE BREATHER CAP IS LOCATED ON THE TOP SIDE OF THE POWER UNIT RESERVOIR.

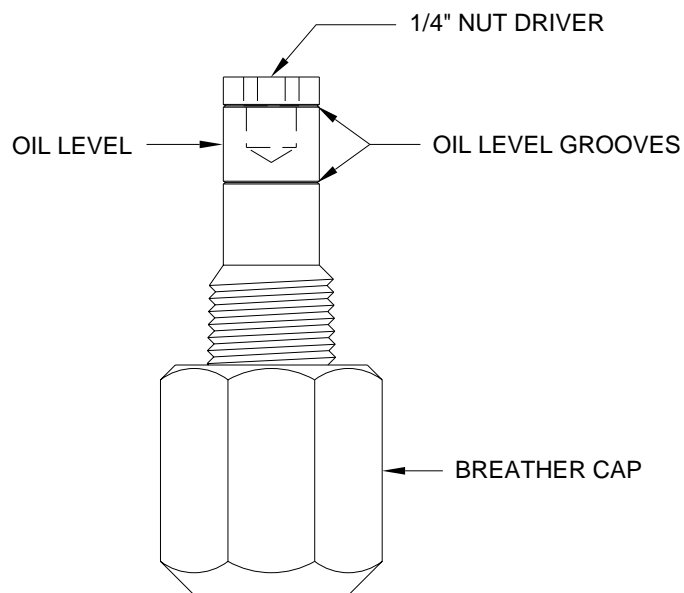

IMPORTANT: PRIOR TO REMOVING THE BREATHER CAP, EITHER TO CHECK THE OIL LEVEL OR TO USE THE 1/4" NUT DRIVER, CLEAN ANY DEBRIS FROM THE TOP OF THE RESERVOIR. BEFORE RETURNING THE BREATHER CAP TO THE RESERVOIR, REMOVE ANY PAINT CHIPS OR OTHER DEBRIS FROM THE DIPSTICK INCLUDING DEBRIS INSIDE THE 1/4" NUT DRIVER.